



Engineering Standard

SAES-L-450

10 November 2012

Construction of On-Land and Near-Shore Pipelines

Document Responsibility: Piping Standards Committee

Saudi Aramco DeskTop Standards

Table of Contents

1	Scope.....	2
2	Conflicts and Deviations.....	2
3	References.....	2
4	Definitions.....	4
5	Applicable Codes and Standards.....	4
6	Design Package and Project Records.....	4
7	Pipeline Route, Profile and Right of Way.....	4
8	Storage and Handling.....	5
9	General Fabrication Requirements.....	6
10	Line Pipe Bends and Bending.....	6
11	Pipeline Stringing (General).....	10
12	Installation Types.....	11
13	Installation of Aboveground Pipelines.....	11
14	Installation of Buried Pipelines.....	12
15	Tie-in Temperatures.....	17
16	Trenchless Pipeline Construction.....	19
17	Coating and Cathodic Protection.....	19
18	Pressure Testing, Cleaning and Inspection...	20
19	Clean-up, Records.....	20
	Appendix A – Elastic Bends.....	21
	Appendix B – Preformed Cold Bending of Line Pipe.....	24
	Appendix C – Calculations for Required Cover.....	26
	Appendix D – Buried Pipelines Installation Details.....	30

Previous Issue: 31 December 2011 Next Planned Update: 31 December 2016

Revised paragraphs are indicated in the right margin

Primary contact: Nasri, Nadhir Ibrahim on 966-3-880-9603

Page 1 of 30

1 Scope

- 1.1 This standard supplements [ASME B31.4](#) and [ASME B31.8](#) transportation piping codes and defines additional construction requirements governing onshore cross-country pipelines.
- 1.2 This standard is applicable to both metallic and non-metallic line pipe.
- 1.3 This standard is not applicable to offshore and sub-sea pipelines.

2 Conflicts and Deviations

- 2.1 Any conflicts between this standard and other applicable Saudi Aramco Engineering Standards (SAESs), Materials System Specifications (SAMSSs), Standard Drawings (SASDs), or industry standards, codes, and forms shall be resolved in writing by the Company or Buyer Representative through the Manager, Consulting Services Department of Saudi Aramco, Dhahran.
- 2.2 Direct all requests to deviate from this standard in writing to the Company or Buyer Representative, who shall follow internal company procedure [SAEP-302](#) and forward such requests to the Manager, Consulting Services Department of Saudi Aramco, Dhahran.

3 References

The selection of material and equipment, and the design, construction, maintenance, and repair of equipment and facilities covered by this standard shall comply with the latest edition of the references listed below, unless otherwise noted.

3.1 Saudi Aramco References

Saudi Aramco Engineering Procedures

SAEP-122	<i>Project Records</i>
SAEP-302	<i>Instructions for Obtaining a Waiver of a Mandatory Saudi Aramco Engineering Requirement</i>
SAEP-311	<i>Hot Tap and Stopping Procedure</i>
SAEP-351	<i>Assembly of Bolted Flanged Joints</i>

Saudi Aramco Engineering Standards

SAES-A-004	<i>General Requirements for Pressure Testing</i>
SAES-A-007	<i>Hydrostatic Testing Fluids and Lay-Up Procedures</i>

<u>SAES-B-064</u>	<i>Onshore and Nearshore Pipeline Safety</i>
<u>SAES-H-001</u>	<i>Selection Requirements for Industrial Coatings</i>
<u>SAES-H-002</u>	<i>Internal and External Coatings for Steel Pipelines and Piping</i>
<u>SAES-H-200</u>	<i>Storage, Handling, and Installation of Externally Coated Pipe</i>
<u>SAES-L-100</u>	<i>Applicable Codes & Standards for Pressure Piping Systems</i>
<u>SAES-L-101</u>	<i>Regulated Vendors List for Pipes, Fittings and Gaskets</i>
<u>SAES-L-110</u>	<i>Limitation on Piping Joints and Components</i>
<u>SAES-L-125</u>	<i>Safety Instruction Sheet for Piping and Pipelines</i>
<u>SAES-L-150</u>	<i>Pressure Testing of Plant Piping and Pipelines</i>
<u>SAES-L-410</u>	<i>Design of Offshore Pipelines</i>
<u>SAES-L-460</u>	<i>Pipeline Crossings under Roads and Railroads</i>
<u>SAES-L-470</u>	<i>Trenchless Pipelines Construction Requirements</i>
<u>SAES-Q-001</u>	<i>Criteria for Design and Construction of Concrete Structures</i>
<u>SAES-Q-005</u>	<i>Concrete Foundations</i>
<u>SAES-W-012</u>	<i>Welding Requirements for Pipelines</i>
<u>SAES-X-400</u>	<i>Cathodic Protection of Buried Pipelines</i>

Saudi Aramco Materials System Specifications

<u>01-SAMSS-010</u>	<i>Fabricated Carbon Steel Piping</i>
<u>01-SAMSS-012</u>	<i>Submarine Pipe Weight Coating</i>

Saudi Aramco Standard Drawings

<u>AB-036907</u>	<i>Cathodic Protection, Pipeline KM Marker and Test Station</i>
<u>AD-036973</u>	<i>Marker Plates for Pipeline Kilometer Marker</i>

3.2 Industry Codes and Standards

American Society of Mechanical Engineers

<u>ASME B31.4</u>	<i>Pipeline Transportation Systems for Liquid Hydrocarbons and Other Liquids</i>
-----------------------------------	--

[ASME B31.8](#)

Gas Transmission and Distribution Piping Systems

4 Definitions

All definitions listed in [SAES-L-100](#) shall apply to this standard, including the following:

- Cross Country Pipelines
- Design Factor
- Flowlines (including trunklines and testlines)
- Production Pipelines
- SA PMT
- Wellhead Piping

Construction Contractor: The agency responsible for executing the construction of the pipeline.

5 Applicable Codes and Standards

In addition to referenced Codes and Standards within the context of this standard, the applicable codes and standards in accordance with [SAES-L-100](#) shall apply.

6 Design Package and Project Records

- 6.1 The construction of the pipeline shall follow the approved design package as required per [SAES-L-410](#).
- 6.2 The Construction Contractor may issue detailed design drawings, sketches and procedures as needed during the course of construction or as specified in the Project Scope of Work. These shall be approved by Saudi Aramco PMT and the Proponent Representative prior to implementation.
- 6.3 Saudi Aramco PMT is responsible for updating the as built drawings. They shall ensure that Construction Contractor is recording the as built information.

The Saudi Aramco PMT shall approve the Construction Contractor's final profile.

7 Pipeline Route, Profile and Right of Way

- 7.1 Pipeline Route and Profile
 - 7.1.1 The pipeline route as stipulated on the Issued for Construction (IFC) drawings shall be surveyed and staked by the Construction Contractor. Changes to original routing may be acceptable with prior approval per [Section 6](#).
-

- 7.1.2 The Construction Contractor shall field verify the original vertical profile of the pipeline, the amount of cover, the location and degree of elastic and preformed bends, in accordance with this standard and the construction drawings. The change in slope of the pipeline at normal spacing of 30 m, and at intermediate stations as required, shall be calculated.
- 7.1.3 Fills and cuts shall be made to reduce the number and/or magnitude of overbends and sagbends in the pipeline. Fills should be avoided in areas where the natural drainage of the surrounding area is affected.
- 7.1.4 Provisions shall be made to prevent wash-out of the pipeline cover by rain storms if the pipeline construction changes the natural drainage pattern.
- 7.2 Pipeline Right of Way (ROW)
 - 7.2.1 The construction right-of-way shall be graded to a flat or smooth rolling surface and shall be maintained accessible with standard four-wheel drive vehicles on at least one side of the line during construction period. Irregularities shall not obstruct access of construction equipment.
 - 7.2.2 In sabkha areas, fills shall be provided to support construction equipment as required. The width of such fills and cuts shall not be less than the area to be stabilized in accordance with [Section 14](#), and the adjacent slopes shall not be steeper than four to one. The construction and final right of way shall not be less than 6 meters.
 - 7.2.3 In sand dune areas, the width of leveled, stabilized right-of-way shall be 3 m on each side of the pipeline plus 1 m for every 1 m of dune height (or fill height) in both the “cut” and the “fill” areas.
 - 7.2.4 The final finished right-of-way shall be at least 5 meters (6 meters in sabkha areas and 3 meter in sand dune areas) wide from bottom edge of pipeline berm. It shall be completed in a manner which permits routine operation and maintenance access with standard four-wheel drive vehicles.

8 Storage and Handling

- 8.1 The pipe handling procedure and equipment shall be approved by the Saudi Aramco PMT.
 - 8.2 Storage, handling, and installation of pipe that is externally coated shall be in accordance with [SAES-H-200](#).
 - 8.3 Pipe stacking shall be made in a manner which will not damage the pipe or the coating.
-

- 8.4 End bevel protectors shall remain on pipes and fittings while in storage, protectors shall not damage internal or external coating.
- 8.5 Slings for lifting pipe shall be nylon or similar material to prevent damage to the pipe surface. Wire rope slings shall not be used.
- 8.6 Pipe shall not be rolled or dropped off trucks.
- 8.7 Internally coated pipe shall be handled from the outside diameter (O.D.) only.
- 8.8 When a length of pipe is cut from a longer joint of pipe, all vendor markings and other identifying information shall be transferred to each length of pipe.
- 8.9 For pipelines in sales gas piping systems, each joint shall be cleaned and capped with durable plastic sheet prior to transportation to the field.

9 General Fabrication Requirements

- 9.1 Vents and drains in accordance with [SAES-L-110](#) shall not be installed unless included in the approved design drawings.
- 9.2 Installation of temporary vents and drains is not permitted without prior approval per [Section 6](#). If temporary vents are field installed, nipples and valves shall be removed and bosses shall be plugged, seal welded and penetrant tested after the hydrostatic test.
- 9.3 Drains shall not be installed at the bottom of the pipe for buried pipelines.
- 9.4 The assembly of bolted flange joints shall be in accordance with [SAEP-351](#).
- 9.5 Connections to existing piping systems by means of hot tap and stoppling shall be in accordance to [SAEP-311](#).
- 9.6 Pipeline kilometer marker plates shall be according to Standard Drawings [AB-036907](#) and [AD-036973](#).

10 Line Pipe Bends and Bending

- 10.1 This section provides the requirements related to the pipeline bends and bending. However, deviation is acceptable if supported with proper calculation and past experiences subject to approval of by PMT and the Chairman of the Piping Standards Committee or a Piping Specialist of CSD.

10.2 Limitation on Horizontal Bend Radius

10.2.1 Aboveground Un-restrained Pipelines

Long radius elbows are the standard methods for achieving horizontal bends. The bend radius shall be 5-D type if the pipeline is required to allow passage of instrument scrapers.

10.2.2 Aboveground Restrained Pipelines

10.2.2.1 There is no limit on the minimum bend radius in specific, however the pipe supports and anchor shall be designed adequately to withstand thrust forces in the pipelines. However, the practice is to use wide long radius bends to allow for less conservative pipe support design and construction if there are no space limitations.

10.2.2.2 For aboveground restrained pipelines, all horizontal deflections shall be made at deflection anchors and consist of a series of very large radius field bends held in special supports designed for horizontal thrust, as shown on the Project Drawings.

10.2.2.3 For larger bend angles that are not accounted for on project drawings, additional support shall be provided symmetrically distributed along the bend curve. The number and location of the supports shall be approved by the Saudi Aramco Representative.

Commentary Note:

For aboveground restrained pipelines, the support design usually limits the angle of vertical bend per support to a maximum as indicated in the Project Drawings or Specifications.

10.2.3 Buried Restrained Pipelines

The standard design is to use 210 meter wide long radius bends if there are no space limitations. Bend radius per applicable ASME code is permitted if supported with calculations or past experience.

Commentary Note:

The long radius will allow for the minimum pipe cover and will be sufficient to restrain the pipeline within the berm and to reduce pipe longitudinal stresses.

10.3 Limitation on Vertical Bend Radius

10.3.1 Aboveground Un-restrained Pipelines

A detail analysis shall be conducted to verify that the pipeline will meet Code requirements for stresses and the pipeline will be in contact with pipe supports at all times.

10.3.2 Aboveground Restrained Pipelines

The support design shall limit the angle of vertical bend per support to a maximum as indicated in the Project Drawings or Specifications. There is no limitation on the minimum bend radius. However, the pipe supports and anchor shall be designed to adequately withstand lifting thrust forces created by the pipelines.

Commentary Note:

For aboveground restrained pipelines, the support design usually limits the angle of vertical bend per support to a maximum as indicated in the Project Drawings or Specifications.

10.3.3 Buried Restrained Pipelines

Vertical over or sag bends shall be avoided as much as possible. The pipeline shall be adequately restrained to prevent the line from lifting up out of the berm (bowing out). This could be achieved by proper soil cover or other means approved by the Chairman of the Piping Standards Committee.

Commentary Note:

The available computer software to perform such calculations are Pipecover and ADBP which are available with the Company. Piping Group of CSD may be contacted for details.

10.4 Limitation on Composite Bend Radius

For composite bends having both vertical and horizontal components, the overall bend radius shall be limited to requirements in [Appendix B](#). [Appendix C](#) of this specification contains sample calculations for required covers at over bends.

10.5 Elastic Bending

The maximum change in slope for elastic bends shall be in accordance with the Project Specification or the Scope of Work. [Appendix A](#) of this standard contains sample calculations for permissible elastic bending. When changes of

the vertical or horizontal slope are larger than permissible for elastic bending, the pipeline bends shall be made with preformed hot or cold bends.

10.6 Cold wrinkle bends and field hot bends are not permitted. Shop hot bends shall be in accordance with [01-SAMSS-010](#) and shall be procured from an approved manufacturer per [SAES-L-101](#).

10.7 Preformed Cold Bending

10.7.1 Preformed cold field and/or shop bending of line pipe shall follow the requirements of [Appendix B](#). Any alteration or deviations to the requirements of this appendix shall be approved by the Piping Standards Committee Chairman or his representative.

10.7.2 The final dimension (angle, length and radius) of the preformed bends shall meet the requirement dictated by the actual field measurements.

10.7.3 During construction, the end of pipe strings shall be chosen such that the maximum allowable angle of preformed bend per support decreases as the distance between the bend and either free end of the string increases as shown in Table 1.

Table 1 – Maximum Allowable Bend per Support

Distance from End of String (meter)	Degrees per Support	Change in Slope
0 to 60	10	0.1745
60 to 120	8	0.1396
120 to 180	6	0.1047
180 to 275	4	0.0698

Commentary Note:

This is to achieve smooth bend radius and optimum load distribution on pipe supports especially for fully restrained above-ground pipelines.

10.8 Aboveground Unrestrained Pipelines

10.8.1 For above ground pipelines at road crossings where preformed bends are required, the bend angle and bite shall be per [Appendix B](#).

10.8.2 The bend shall be located so that the peak of the bend is located between two pipe supports and does not reside on pipe supports.

10.9 Aboveground Restrained Pipelines

10.9.1 For aboveground restrained pipelines, all horizontal deflections shall be made at deflection anchors and consist of a series of very large radius field bends held in special supports designed for horizontal thrust, as shown on the Project Drawings.

10.9.2 For larger bend angles that are not accounted for on project drawings, additional support shall be provided symmetrically distributed along the bend curve. The number and location of the supports shall be approved by the Saudi Aramco Representative.

Commentary Note:

For aboveground restrained pipelines, the support design usually limits the angle of vertical bend per support to a maximum as indicated in the Project Drawings or Specifications.

10.9.3 The curve with relatively short tangent section to either side, shall be made as a separate string to avoid deflection and the slipping off of supports before being fully restrained.

11 Pipeline Stringing

11.1 The installation requirements of this section shall apply to all pipelines regardless of the construction type.

11.2 Each length of pipe shall be examined to make sure it is free from internal obstructions. Any obstructions shall be removed before the pipe is welded into a string. Each joint shall also be air blown to remove dust and sand immediately prior to welding into a string.

11.3 Pipe joints shall be welded in accordance with [SAES-W-012](#) to form strings of 900 to 1200 m. Pipe strings or portions thereof shall not be moved until all joints have been fully welded and inspected.

Pipe strings shall be supported and laterally restrained by an approved pipeline support methods such as pig pen pipeline support, air bag or earth pillar methods.

11.4 Open ends of pipeline strings shall be capped to prevent entry of debris or animals and birds.

11.5 Each string of the pipeline shall be cleaned to remove all debris. Additionally, a valve site to valve site cleaning shall be performed before installing the valves into the pipeline.

- 11.6 In hilly terrain the strings shall be laid in a manner to avoid buckling due to temperature changes before the line is held down by ring girder supports. [Appendix B](#) could be used as guidance.
- 11.7 Except for internally coated pipe, each string shall be gauged by passing an internal gauging plate of not less than 90% of the inside diameter for pipe sizes smaller than 20-inch and 93% for pipe sizes 20-inch and larger.

12 Installation Types

- 12.1 The installation type shall follow the project specification and detailed design drawings. However, if technically or economically justified the type of installation could be altered with prior approval by PMT, Chairman Piping Standards Committee and the Proponent Department. Loss Prevention shall be in the approval process if the alteration entails violations to [SAES-B-064](#).
- 12.2 The installation types of pipelines used by Saudi Aramco are the following:
 - 12.2.1 Above ground unrestrained: The pipeline is installed above ground or over water surface. The pipeline is free to expand due to thermal expansion by means of expansion loops or offsets.
 - 12.2.2 Above ground fully restrained: The pipeline is installed above ground or over water surface and is held down by means of ring girders or similar to limit lateral and vertical movement. The line is held by end anchors which will limit its axial movement.
 - 12.2.3 Under-ground restrained: The pipeline is installed buried in the ground and covered with soil composed from sand and marl. The details of burial, are dependent on the soil type as detailed in [Section 14](#) below.

13 Installation of Aboveground Pipelines

- 13.1 Pipe support spacing and type shall be in accordance with the plan and the profile drawings, the Project Specification or the Scope of Work.
- 13.2 When changes of slope are required during construction of above ground restrained pipeline, the slope shall be calculated from the actual support elevations and distances, and shall comply with the limitations set forth in [Table 1](#). The preformed bend shall be welded to the pipe string such that its center will be on the support at which the change in slope occurs. Refer to paragraph [10.7.3](#).
- 13.3 Ring girders shall be installed within ± 6 mm horizontal and vertical tolerances.

- 13.4 Driven piles shall be coated in accordance with [SAES-H-001](#) to prevent corrosion and shall be driven in accordance with Project Specification.
- 13.5 Concrete supports shall use concrete in accordance with [SAES-Q-001](#). The concrete shall have a minimum compressive strength of 28 MPa (4000 psi) after curing.
- 13.6 The pipe supports shall be installed on a stable base material to prevent future settling. The base of each support shall be at least 1.8 m in diameter and shall comply with [SAES-Q-005](#). Determination of the type of stabilization should generally be based on the economics of the two stabilization options.

14 Installation of Buried Pipelines

- 14.1 Existing buried installations crossing the pipeline route shall be located in prior to grading, excavation and trenching.
 - 14.2 If the pipeline crosses or comes within 50 meters of buried pipelines or is within 50 m of other buried steel installations, the Cathodic Protection Unit of CSD shall be contacted to determine if bonding stations are needed. All bonding stations shall be completed and the line backfilled within the time frame specified in [SAES-X-400](#). The as-built drawings shall indicate any buried installations and bonding stations.
 - 14.3 Pipelines Clearances
 - 14.3.1 The minimum clearance between pipelines or between a pipeline and an obstruction shall be as specified above unless additional clearance is specified on the construction drawings.
 - 14.3.2 The berm of the new pipeline shall not disturb the flexibility of adjacent above ground pipelines and shall not cause damage to pipelines with heat tracing such as sulfur pipelines. A minimum clearance of 3 meter is recommended.
 - 14.4 The trench bottom shall be surveyed to establish the elastic bends and required preformed bends in rolling terrain such as passing through sand dunes & hilly terrain. When the pipe is lowered into the trench, the pipe shall conform to the trench bottom and shall be supported at all points.
 - 14.5 Prior to backfilling and during lowering, the pipeline shall be supported inside the trench with a maximum allowable unsupported length of 3 meters (m). Any voids below the pipe shall be carefully backfilled.
-

14.6 Pipe Cover

- 14.6.1 Spot backfilling shall be used to restrain the pipe after it has been lowered into the trench. Spot backfill shall have full specified cover and shall cover all preformed bends a distance of 6 m to each side of the centers of the bends. The maximum clear distance between spot backfills shall be as specified by the project design. Spot backfills shall cover the pipe for at least 4.5 m along the pipe.
- 14.6.2 The Construction Contractor shall follow the Project specifications where extra cover is required at vertical, horizontal, and composite preformed bends based on bend radius and tie-in temperature, to adequately restrain the buried pipeline. Such extra cover shall extend a minimum of 6 m beyond a bent portion of pipe. However, during construction it is the construction contractor's responsibility to implement requirements at locations that have not been identified earlier.
- 14.6.3 All pipelines shall have a minimum cover of 900 mm. Additional cover is required at road or rail crossings, pipeline over bends and when it is required by the quantitative risk assessment. [Appendix C](#) of this specification contains sample calculations for required covers at over bends.
- 14.6.4 For Khuff Gas lines, and high temperature lines (180°F and above), pipeline movement indicators shall be installed at the vertical and composite bends to monitor the pipe movement. The number of indicators and their locations shall be obtained from the Operating Department.
- 14.7 Diversion ditches and/or culverts for flood water shall be provided to keep the pipeline cover from acting as a dam or a channel bank.
- ## 14.8 Installation in Sand Areas
- 14.8.1 Typical Installation is detailed in [Appendix D](#). The trench shall be wide enough to allow lowering the pipe without damaging the pipe or the coating and shall be excavated to the depth required to provide the specified depth of cover as required by [SAES-L-410](#). The top of pipe shall not be closer to finished grade than by more than half the total cover specified. The remainder of the cover can be a stabilized berm or dike above the finished grade.
- 14.8.2 The bottom of the trench shall be free of rock or other material that could damage the pipe or pipe coating.
-

- 14.8.3 The pipe shall be embedded in clean sand not less than 200 mm above the top of pipe in a manner which shall not damage the coating. The sand shall not contain stones larger than 12 mm size.
- 14.8.4 The remainder of the backfill shall be placed in a manner which shall not disturb the layer of clean sand around the pipe (sand pad). Backfill shall not contain rock larger than 50 mm size.
- 14.8.5 For active sand areas, the backfill shall be stabilized with marl of 152 mm minimum depth, or approved environment friendly stabilization materials with a minimum of 13 mm penetration.
- 14.8.5.1 Weathered crude oil shall not be used without the approval of the Chief Environmental Engineer, Environmental Engineering Division, EPD and the Piping Standards Committee Chairman.
- 14.8.5.2 When the buried pipeline is installed through a moving sand dune area, the sand bedding under the pipe and backfill over the pipe shall be compacted to provide additional restraint around the buried pipe to reduce pipe deflection and stress under the weight of sand dune.

Commentary Note:

The pipeline shall be analyzed to verify that the stresses due to excessive sand overburden are within the allowable.

14.9 Installation in Rock Areas

- 14.9.1 Normally, aboveground construction shall be used in rock areas where blasting would be required for trenching.
- 14.9.2 Direct Laying

When there is economic justification and no technical complications, the pipelines may be laid directly on a 150 mm (6 inch) sweet sand pad and then buried with the required pipe cover. This method is acceptable under the following conditions:

- a) The line size is 12 inch pipe size or less.
- b) The actual flowing temperature is less than 160°F.
- c) The cost of trenching and/or blasting is more than the cost of additional sand cover.

- d) The rocky area is relatively very flat and no severe overbends exist along the route of the line.
- e) The PMT and Chairman of the Piping Standards Committee reviews the details.

14.9.3 Half trenching

When there is economic justification, a “half trenching” alternative may be used as follows: (Typical Installation is detailed in [Appendix D](#)).

- a) The minimum trench depth shall be such that the top of the pipe is below the original ground surface by 50 mm in rippable or hard marl areas and/or the pipe centerline is 150 mm below the top of the finished grade when the top of rock layer is closer to finished grade elevation by more than half pipe dia. plus 150 mm.
 - b) The minimum width of the bottom of the trench in rock areas shall be 600 mm wider than the pipe. The pipe shall be centered in the trench.
 - c) Selected bedding material shall be placed in the bottom of the trench and made level. The bedding material shall be clean sand or soil and shall not contain stones larger than 12 mm size that would cause damage to the pipe or pipe coating. The bedding material shall be minimum 100 mm thick and shall cover all rock protrusions. In addition, sand pads or sand bags shall be placed at approximately every 9 m to support the pipe 100 mm off the prepared bottom. The bottom of the trench shall be inspected to insure that no rocks are protruding through the bedding layer.
 - d) After lowering the pipe into the trench, the Contractor shall use surveying sticks to establish dimensional controls to satisfy the inspector that the final cover will be sufficient and centered over the pipeline.
 - e) A pad of selected bedding material shall be placed under and around the pipe to provide a minimum cover of 200 mm above the pipe. The sand pile remaining above the 200 mm cover shall be shaped to its natural angle of repose, approximately 35 degrees from the horizontal.
 - f) The remaining backfill and berm shall be placed in a manner to avoid disturbing the sand pad. Coarse material shall not be placed on top of the sand pad and be allowed to roll down. Backfill shall not contain rock larger than 150 mm size.
-

- g) The width of the flat top of the dike berm shall be at least twice the pipe diameter along the overall minimum cover above the top of the pipe. For every 300 mm of additional cover required at vertical or horizontal bends, the berm width shall be increased 600 mm. The ramped sides of the dike shall not be steeper than 35 degrees.
- h) The entire dike shall be stabilized with marl of 152 mm minimum depth or by spraying with weathered crude oil to saturate the outer surface. The crude shall penetrate a minimum of 12 mm.

Commentary Note:

Typically, this requires approximately 4.5 L/m² (1 gal/yd²) of berm surface.

- i) Diversion ditches and/or culverts for flood water shall be provided to keep the pipeline cover from acting as a dam or a channel bank.

14.10 Installation in Sabkha Areas

- 14.10.1 In sabkha areas, pipe shall be laid in a trench dug in a compacted sand fill construction road which has been placed on the undisturbed ground surface. Typical Installation is detailed in [Appendix D](#).
- 14.10.2 The construction pad shall be wide enough to permit the centerline of the trench to be dug. The pad width shall not be less than 6 times the pipe outside diameter. The sides of the fill shall not be steeper than 35 degrees. The top of the pipe shall be below the level of the construction road by at least 100 mm.
- 14.10.3 The berm over the pipe shall be placed in accordance with paragraph 14.9.3 items f through i.
- 14.10.4 For new construction, the bottom of the pipe shall not be less than 150 mm above the highest recorded groundwater level.

14.11 Installation in Rivers and Wadis

When a buried pipeline is installed through a river bottom, wadi, or other places where water run-off occurs, concrete coated pipe in accordance with [01-SAMSS-012](#) shall be used to provide the required stability in case of floods. The use of concrete blocks placed over the pipeline is prohibited. Alternative methods to provide stability shall be reviewed and approved by the Supervisor of Civil Engineering Unit in CSD and the Chairman of the Piping Standards Committee.

15 Tie-in Temperatures

15.1 A temperature tie-in weld is a weld that connects one of the following:

- Two pipeline strings together
- An existing pipeline to a pipeline under construction
- A pipeline to an anchor
- Pipeline sections to an intermediate mainline valve that is being inserted.

The segment of the pipeline between tie-in points remains fully restrained at the tie-in temperature if expansion or shrinkage of the segment is prevented by adequate anchorage at both ends. For normal daily temperature variations during construction, one of the following will provide adequate anchorage:

- An anchor on the end of pipeline upstream of the welding progression along with friction forces on the tail
- At least 450 m of buried pipeline downstream of the tie-in weld
- A 900 m to 1200 m pipeline string on wooden skids or sand
- An 1800 m to 2400 m pipeline string resting on steel supports.

15.2 The Construction Engineer shall determine the highest practical tie-in temperature for each tie-in weld. The tie-in temperature shall be within the range stated in the Project Specifications.

15.3 The actual tie-in temperature shall be the average of two readings, one at the top and one at the bottom of the pipe. If a contact measuring device is used, it shall be shielded from direct sunlight to prevent an inaccurate reading.

15.4 The Contractor shall record all tie-in temperatures and the pipeline stations of the tie-ins. These readings shall be recorded in the inspection record books.

15.5 Method of Tie-in for Buried Pipelines

15.5.1 When a sufficient number of strings have been completed, the first string of a buried pipeline shall be placed in the trench and spot backfilled (or tied into an anchor) during the hottest part of the day. The subsequent strings shall be connected by temperature tie-in welds. Each new string must be kept free of movement to prevent cracks in the tie-in weld.

15.5.2 The portion of the pipeline outside the trench shall be supported by side booms holding the line in a gentle S-curve. During the night and the cool periods of the day, there should be at least 900 m to 1200 m of

pipe outside the trench to keep the S-curve in sufficient tension to restrain the pipe already in the trench.

- 15.5.3 If the S-curve cannot fully restrain the line during the cool periods, the curve will develop slack as the line becomes warm. This will require placing the tail on rollers in order to move the slack towards the free end of the line when the temperature is high.
- 15.5.4 Spot backfilling (used to anchor to the line) may be completed at any temperature but no closer than 1200 m from the free end of the tail. If spot backfilling closer to the free end is required, it shall be done during the hottest part of the day.
- 15.5.5 If desired, the tie-in weld may be made with the pipe in the trench (at tie-in temperature). The tail may also be in the trench, however, the string being tied in and the tail must be spot backfilled on the same day of the tie-in. The spot backfilling shall not be closer than 24 meters from the free end.

15.6 Method of Tie-in for Aboveground Restrained Lines

- 15.6.1 When a sufficient number of strings have been completed, the starting end of the pipeline shall be tied in to a full thrust anchor or to a minimum of 600 meters of buried pipeline using a temperature tie-in weld.
- 15.6.2 The strings which have been tied-in while resting on the skids or on the sand shall be placed onto the supports by side booms, holding the line in a gentle S-curve between supports and skids. The pipeline that has been placed onto the supports shall have the top halves of ring girder supports or support straps bolted in place on the same day it is placed.
- 15.6.3 There shall always be at least 900 m to 1200 m of pipe attached to the line on skids or on the ground to restrain it during the night and cool periods of the day.
- 15.6.4 As an alternative, pipeline strings may be welded while resting on permanent supports but only if the supports are designed to resist the friction forces of the line developed under full temperature differential.
- 15.6.5 Two strings on supports may be tied together with a temperature tie-in weld. This 1800 m to 2400 m double string may then be tied in to the pipeline at normal daily temperatures. However, the pipeline being tied into must have an end anchor or be buried in order to obtain the highest possible effective tie-in temperature.

15.7 Optional Welding Method for Above-ground Restrained Pipelines

The line may be welded one joint at a time from one end to the other end without temperature tie-ins other than the final weld and without restriction in length. This method can be used only if the average day and night pipe temperatures don't exceed the design tie-in temperatures. When this technique is used, the supports shall be designed to resist pipe to support friction forces under the full temperature differential. Additional precautions, such as greasing supports or lifting the pipe to permit relative movement shall be taken to limit bending of supports. The final weld shall be made at or above the mean pipe temperature for the three days prior to the final tie-in. This mean pipe temperature shall be recorded as the actual tie-in temperature for the pipeline.

15.8 Method of Tie-in for Aboveground Non-restrained Pipelines

Tie-in welds shall be made in a manner to avoid overloading intermediate anchors that are not designed to take the pipe support friction force developed by a pipeline string connected to one side only. A string shall always be connected to each side of the anchor stub when the work is stopped at the end of the day. During the day, the time during which only one string is connected shall be kept to a minimum.

16 Trenchless Pipeline Construction

16.1 Trenchless pipeline construction should be considered for the following:

- Road and highway crossings.
- Offshore approach for subsea pipelines.
- Sea and river crossings.
- Pipeline corridor crossings.
- Equipment crossing such as SSD fence.
- Sand dunes crossings.

16.2 Pipeline trenchless construction shall be in accordance with [SAES-L-470](#).

17 Coating and Cathodic Protection

For externally coated pipe, the required coating, holiday testing and repair shall be in accordance with [SAES-H-200](#) prior to burial. The cathodic protection shall be in accordance with [SAES-X-400](#).

18 Pressure Testing, Cleaning and Inspection

- 18.1 Hydrostatic testing shall be in accordance with [SAES-L-150](#), [SAES-A-004](#), and [SAES-A-007](#).
- 18.2 The pipeline shall be cleaned per a detailed procedure that will account for end service. For example, a flowline in crude service may not require extensive cleaning procedure while a sales gas pipeline connecting to the master gas system requires more extensive cleaning procedures.

19 Clean-up, Records

- 19.1 Construction waste materials shall be removed from the right-of-way as the construction progresses.
- 19.2 Record books, per [SAEP-122](#), shall be sent to the EK&RD/Drawing Management Unit, Dhahran.

All survey data and as-built drawings shall be sent to the EK&RD/Drawing Management Unit. The following information shall be included:

- a) Bottom-of-line elevations and ground elevations at all 30 m stations and at all preformed bends;
- b) The location and degree of all horizontal bends;
- c) The location and degree of all preformed sagbends and overbends;
- d) The location of all vents and drains;
- e) The identification, station, elevation, and size of all pipes which cross the pipeline and of any other buried steel installations within 30 m;
- f) The stations of all markers, appurtenances and cathodic protection facilities;
- g) All other data which should be included on a maintenance record profile, including the stations of block valves, anchors, road crossing, and changes in the grade of the pipe, wall thickness, diameter, and water run off areas.
- h) Safety Instruction Sheets per [SAES-L-125](#).

31 December 2011
10 November 2012

Revision Summary
Major revision.
Editorial revision.

Appendix A – Elastic Bends

Following are examples of calculations for permissible elastic bending.

A.1 Buried Pipelines

[ASME B31.4](#), paragraph 419.6.4(b) does not require that the bending stress in buried pipelines be included in the calculation of the equivalent tensile stress. However, this is required by [SAES-L-410](#).

Example 1: (Add Formulas)

26-inch OD pipe, 6.35 mm wall, Grade X52

$D = 0.660$ m, $E = 200\,000$ MPa, $SMYS = 358.5$ MPa

Design factor 0.72, maximum temperature 77°C, minimum tie-in temperature 38°C.

Calculation:

Sh (Hoop stress)	= 0.72 SMYS	= 258.1 MPa
St (Temperature stress)	= 2.34 (77 - 38)	= 91.3 MPa
Sc (Max. combined stress)	= 0.9 * SMYS	= 322.6 MPa
Sb (Max. bending stress)	= Sc - 0.7 Sh - St	= 50.7 MPa
R (Min. bend radius)	= ED/(2Sb)	= 1300 m
Angle per 30 m = $30 / (2R)$	= 0.0115 radians	= 0.66 deg
Allow for misalignment	= 0.0044 radians	= 0.25 deg
Permit change of slope	= 0.0071 radians	= 0.41 deg
Max. change of slope 0.0071 x 30000	= 213 mm per 30 m	

Example 2:

6-inch NPS, SCH 40, 7.11 mm wall, Grade B

$D = 168.3$ mm, $E = 200\,000$ MPa, $SMYS = 242.3$ MPa

Design pressure 8300 KPa (1200 psi)

Maximum delta T = 30°C

Calculation:

$$Sh = PD/2t = 8.3 * 168.3/2 * 7.11 = 98.2 \text{ MPa} = 0.40 \text{ SMYS}$$

$$St = 2.34 * 30 = 70.2 \text{ MPa}$$

$$Sc = \text{SMYS (as } Sh < .65 \text{ SMYS)} = 242.3 \text{ MPa}$$

$$Sb = Sc - 0.7 Sh - St = 103.3 \text{ MPa}$$

$$R = ED/(2 Sb) = 163 \text{ m}$$

$$\text{Angle per 30 m} = 30/(2R) = 0.0920 \text{ radians} = 5.25 \text{ deg}$$

Allow for misalignment = 0.0044 radians

Permit change of slope = 0.0876 radians

Max. change of slope $0.0876 \times 30 = 2.6 \text{ m per 30 m}$

A.2 Above-ground Fully Restrained Pipelines

The calculation of bending stress in above-ground pipelines must include the bending stress at supports due to weight and wind load and, in the case of non-restrained pipelines, the bending stress due to thermal expansion. If a computer calculation is made (such as CAESAR-II), it will assume that all bending is elastic bending of an originally straight pipe axis. The calculated bending stress and the maximum principal stress or maximum shear stress can be directly compared with the allowable.

The stress due to change in slope can be approximated as follows:

Example 3:

36-inch OD pipe, 9.52 mm wall, Grade X60

D = 914.4 mm, E = 200 000 MPa, SMYS = 413.7 MPa

Design pressure 5.5 MPa (800 psi)

Line filled with water, support span L = 16 m

Restrained with delta T = 35°C

Calculation:

$$Sh = PD/2t = 5.5 * 914.4/2 * 9.52 = 264.1 \text{ MPa} = 0.64 \text{ SMYS}$$

$$St = 2.34 * 35 = 81.9 \text{ MPa}$$

$$\text{Weight of pipe + water} = 8\,250 \text{ N/m (565 lb/ft)}$$

$$\text{Wind load } 460 \text{ Pa} * 0.914 = 420 \text{ N/m (30 lb/ft)}$$

$$\text{Combined load SQR } (8250^{**2} + 420^{**2}) = 8261 \text{ N/m}$$

$$\text{Bending moment at support } WL^{**2}/12 = 176.2 \text{ kNm}$$

$$\text{Section Modulus} = 0.006063 \text{ m}^3$$

$$\text{Bending stress without change of slope} = 176.2/0.006063 = 29060 \text{ kPa (4215 psi)}$$

The bending stress must be multiplied with an intensification factor calculated for the maximum anchor thrust force 2667.4 kN (600 kip), which is about 1.021 in this case.

$$\text{Bending due to loads} = 1.021 * 29.06 = 29.7 \text{ MPa}$$

$$\text{Combined stress without change of slope} = 0.7 Sh + St + 29.7 = 296.5 \text{ MPa} \\ = 0.72 \text{ SMYS}$$

Available stress for elastic bending = SMYS - 296.5 = 117.2 MPa (Sh less than 0.65 SMYS)

$$\text{Change of slope} = \text{Arc tan } \{Sb * L/(1.7 ED)\} = 0.006 \text{ radians} = 0.35 \text{ deg.}$$

Maximum allowable change in slope per span based on actual ring girder elevation = 0.006 L = 96 mm.

Appendix B – Preformed Cold Bending of Line Pipe

B.1 Workmanship

B.1.1 At any point along a preformed bend, the pipe diameter shall not be reduced by more than 2-½% of the nominal pipe diameter.

Bends shall not be made closer than 600 mm from edge of the line pipe joint (location of the field circumferential welds).

B.1.2 Preformed bends shall be made by welding into the correct location of the string a length of pipe which has been bent with a smooth stretch bending machine.

B.1.3 Bending of spiral wound line pipe shall be conducted with proper tools and performed with skilled operators because spiral wound pipe is more prone to buckling. For example, a hydraulic bending mandrel and polyurethane-lined bending dies should be used for spiral-welded pipe.

B.1.4 For internally coated pipe, the bend angle per bite may be reduced to minimize damage to the coating. (As a minimum, the internal coatings shall withstand the bends described in B.2).

B.1.5 For relatively thin wall spiral-welded pipe, the bend angle per bite may need to be reduced (typically to 75% of normal) to avoid wrinkling the pipe.

B.2 Preformed Bends Bites and Angle

B.2.1 The maximum permissible localized bend or “bite” at one place on the pipe and the minimum spacing of such bites are shown in [Table B1](#).

Table B1 – Maximum Localized Bend

Nominal Pipe Size Inch	Minimum Bite Spacing mm	Maximum Bend Per Bite in Degrees
6	300	4.5
8	300	3.8
10	300	2.8
12	300	2.3
14	300	1.7
16	300	1.5
18	300	1.2
20	450	0.9
24	450	0.75
30	450	0.6
36 and larger	450	0.5

B.2.2 Wide Bends Radius

The wide bend radius of 210 meter can be achieved by applying a maximum bend or “bite” at one place on the pipe of 0.50 degrees and minimum spacing of such bites of 0.9 m.

Appendix C – Calculations for Required Cover

C.1 Overbends

Overbends must be held down by the weight of pipe and soil to counteract the uplift component of the axial restraining force in the hot operating condition. The length of pipe including the bent portion which is contributing to resisting the uplift is the critical length for an axially loaded column. The axial force in the pipe tends to increase the arch height of this length of pipe, lifting it off the bottom of the ditch. The weight of pipe overburden should cause a sag in the same length of pipe which exceeds the increase in arch height to keep the pipe on the bottom of the ditch.

In addition to the combined weight of soil, pipe and fluid, the CSD PICOVER program takes credit for soil friction in the vertical planes on each side of the pipe.

The desired safety factor is to be given. It appears that small diameter pipe (e.g., 8-inch and smaller) needs relatively more cover than large diameter pipe for small angle bends. However, it is reasonable to accept a lower safety factor for small pipe than for large pipe. On this basis, the normal minimum cover of 900 mm would be sufficient for bends up to 2 degrees. Only a small percentage of bends need to be larger than 2 degrees.

C.2 Sagbends

Sagbends are subject to uplift when the line is below the tie-in temperature and (usually) also depressurized. The uplift force is a function of the axial tension and the bend radius.

For small angles, it is assumed that the length of pipe which is effective, is the same as for overbends. The maximum temperature drop will normally not exceed 25°C. Higher temperature drops must be expected in NGL pipelines which can cool due to blow-down. The minimum cover will usually be adequate for all sagbends except when a large temperature drop can occur or when smaller than standard bend radius is used. In the hot operating condition, the sagbends feel a downward load which could double the soil pressure under the pipe. This does not create an unsafe condition.

C.3 Lateral Bends

The net passive soil resistance against the lateral load exerted by the pipeline must be conservatively estimated because frequently, the cover of the line is a mounded fill with a width of only two pipe diameters. The computer program calculates the require cover for three conditions:

- a) minimum width berm.
- b) cover measured to original grade.
- c) ditch in marl or rock.

C.4 A computer program listing and sample output are given below. This computer program was developed by CSD. Assistance in running the program can be provided by CSD upon request.

Example: Pipe Cover Calculations

This example assumes an allowable elastic change of slope up to 0.6 m per 30 meter (0.020 radians = 1.15 degrees).

Pipeline Profile:

Station Meter	Grade Elev. M	Bol Elev. M	Change Elev. M	Slope Tangent	Change of Slope	Angle Pre. Bend	Remarks
0+00	100.9	100.00					
0+30	101.1	100.00	0.00	0.00	+0.020		Elastic
0+60	101.5	100.60	+0.60	+0.020	+0.020		Elastic
0+90	102.7	101.80	+1.20	+0.040	+0.020		Elastic
1+20	104.7	103.60	+1.80	+0.060	-0.020		Elastic
1+50	105.9	104.80	+1.20	+0.040	-0.035	2.00 Deg	Overbend
1+80	106.0	104.95	+0.15	+0.005	0.000		
2+10	106.0	105.10	+0.15	+0.005	-0.020		Elastic
2+40	105.7	104.65	-0.45	-0.015	-0.020		Elastic
2+70	104.5	103.60	-1.05	-0.035	-0.008		Elastic
Intermediate Station			-0.65	-0.043	Crosses 8" F/L Bol 103.60 M		
2+85	104.4	102.95			+0.046	2.63 Deg	Sag Bend
3+00	104.5	103.00	+0.05	+0.003	-0.056	3.21 Deg	Overbend
3+30	102.4	101.40	-1.60	-0.053	+0.070	4.00 Deg	Sag Bend
3+60	102.9	101.90	+0.50	+0.017	+0.014		Elastic
3+90	103.8	102.84	+0.94	+0.031	+0.014		Elastic

Minimum Cover over Buried Pipelines at Bends:

Pipe 24.000 Inch OD, 9.52 mm Wall, SMYS = 358.527 MPa

Area of Steel = 179.56 cm²; I = 808242 cm⁴; Z = 265.17 cm³

Weight of Pipe plus Contents (Oil) is 376.4 kg/m

Internal Pressure at Max. Temp is 5515.8 KPa

Temperature Rise Above Tie-In 33.3°C; Drop 22.2°C

Bend Radius Vertical 104.8 m; Horizontal 209.7 m

Full Restraining Anchor Force is 2034 KN (933 KN Tension)

Critical Length is 28 m

Potential End Movement is 91 mm (Moving Length 320 m)

(Soil Friction 677 kg/m)

Minimum Cover Over (Oil) Lines Is 24 Inch

Safety Factor for Cover Requirement 1.25

Minimum Cover Is Adequate For Overbends Up To 4.7 Degrees

Required Cover for Overbends:

Load (kg/m)	Soil Weight (kg)	Soil Shear (Newton)	Ult. Resis. (Newton)	Degrees	Inch Cover
963	201	23	94	4.5	24
1051	216	26	100	5.0	26
1133	231	29	106	5.5	28
1211	254	33	115	6.0	31
1284	270	36	122	6.5	33
1354	284	40	128	7.0	35
1419	300	43	134	7.5	37
1482	315	47	141	8.0	39
1538	322	48	144	8.5	40
1592	338	52	151	9.0	42
1641	346	54	154	9.5	43
1685	353	56	158	10.0	44
1726	361	58	161	10.5	45
1761	368	60	165	11.0	46
1794	376	62	168	11.5	47
1821	384	65	172	12.0	48
			Larger Than	12.5	49

Minimum cover is adequate for all sagbends.

Horizontal bends: minimum cover is based on a bermed-over cover of minimum width.

Minimum cover is adequate for all horizontal bends.

Appendix D – Buried Pipelines Installation Details

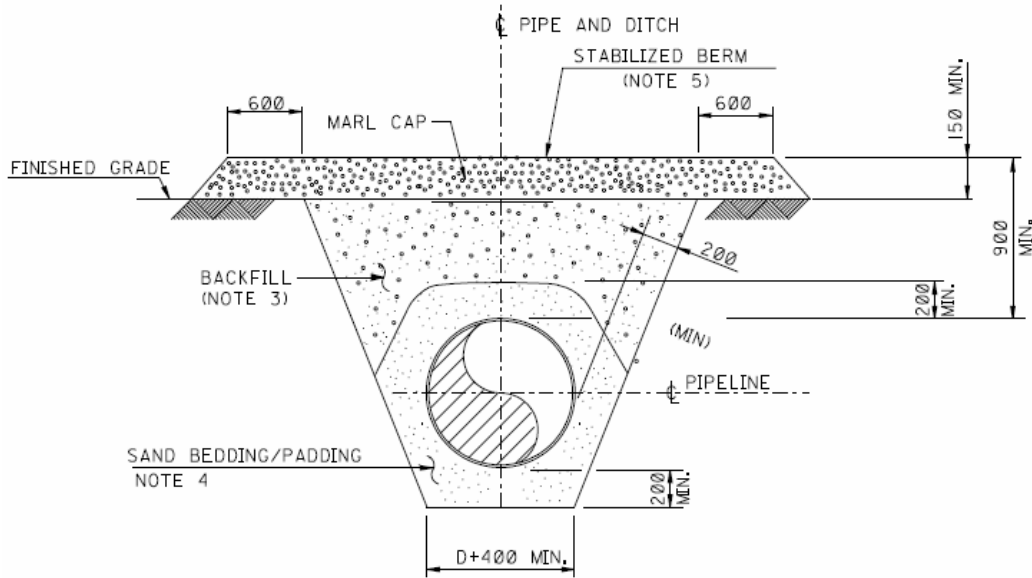

TYPICAL SAND PAD DETAIL

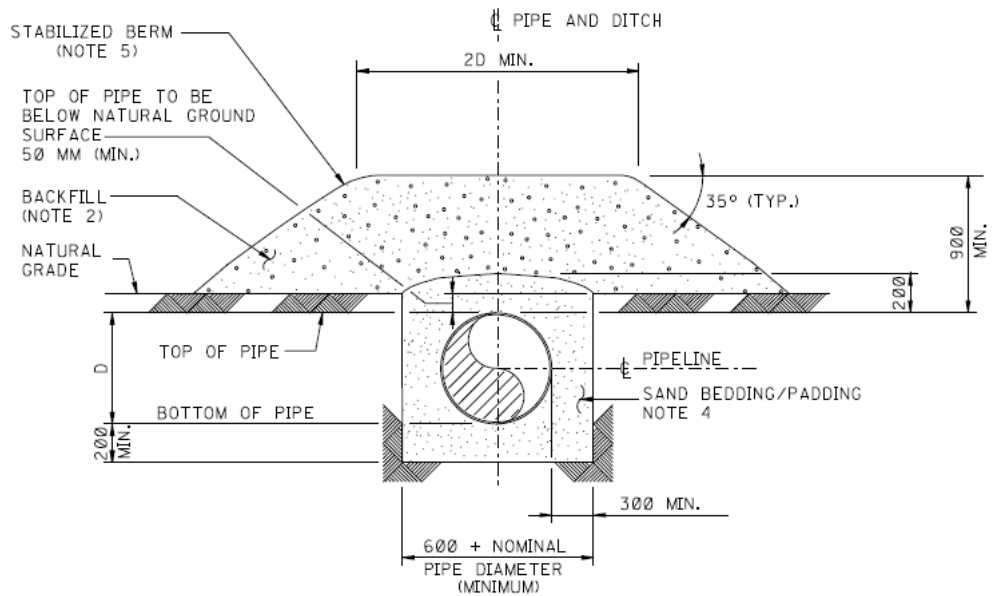

NOTES:

TYPICAL ROCK PAD DETAIL

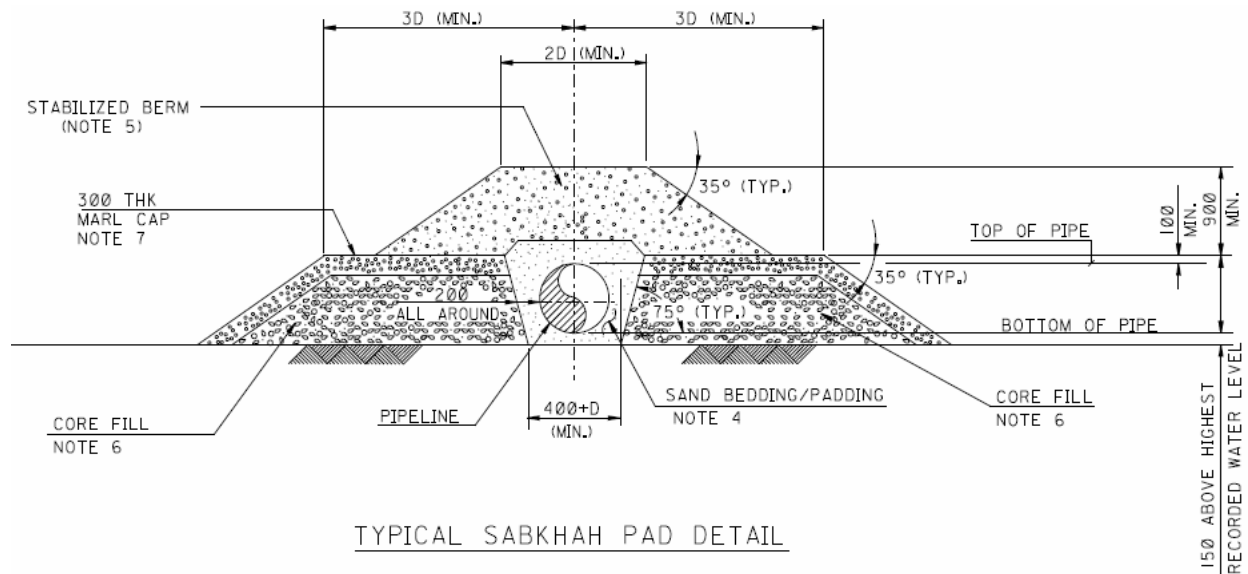

Notes:

1. ALL DIMENSIONS ARE IN MILLIMETERS UNLESS OTHERWISE NOTED.
2. BACKFILL IN ROCK AREAS SHALL NOT CONTAIN ROCK LARGER THAN 150 mm (6 IN.).
3. BACKFILL IN SAND AREAS SHALL NOT CONTAIN ROCK LARGER THAN 50 mm (2 IN.).
4. BEDDING MATERIAL SHALL BE SAND OR SOIL WHICH WILL NOT DAMAGE THE COATING AND SHALL NOT CONTAIN STONE LARGER THAN 12 mm (0.5 IN.).
5. BERM/DUNE SHALL BE STABILIZED WITH 150 THICK MARL OR WEATHERED CRUDE OIL (MIN. 13 mm THICK PENETRATION).
6. FILL SHALL BE PLACED IN LIFTS & COMPACTED TO 95% STANDARD PROCTOR.
7. MAR CAP SHALL BE COMPACTED TO 95% STANDARD PROCTOR.
8. CONTRACTOR SHALL TAKE EXTRA CARE TO AVOID DAMAGE TO EXISTING PARALLEL PIPELINE.
9. AT LOCATIONS WHERE THE NEW PIPELINE IS ADJACENT TO AN EXISTING PIPELINE CONSTRUCTION ROAD, A NEW ROAD IS NOT REQUIRED. AT THESE LOCATIONS, THE EXISTING ROAD IS TO BE EXTENDED AND COMPACTED AS NECESSARY FOR ACCESS TO THE NEW PIPELINE.