

**ASME B31.4-2019**  
(Revision of ASME B31.4-2016)

# **Pipeline Transportation Systems for Liquids and Slurries**

---

**ASME Code for Pressure Piping, B31**

**AN INTERNATIONAL PIPING CODE®**



**The American Society of  
Mechanical Engineers**

**ASME B31.4-2019**  
(Revision of ASME B31.4-2016)

# **Pipeline Transportation Systems for Liquids and Slurries**

---

**ASME Code for Pressure Piping, B31**

**AN INTERNATIONAL PIPING CODE®**



**The American Society of  
Mechanical Engineers**

Two Park Avenue • New York, NY • 10016 USA

Date of Issuance: November 1, 2019

The next edition of this Code is scheduled for publication in 2022. This Code will become effective 6 months after the Date of Issuance.

ASME issues written replies to inquiries concerning interpretations of technical aspects of this Code. Interpretations are published on the Committee web page and under <http://go.asme.org/Interpretations>. Periodically certain actions of the ASME B31 Committee may be published as Cases. Cases are published on the ASME website under the B31 Committee Page at <http://go.asme.org/B31committee> as they are issued.

Errata to codes and standards may be posted on the ASME website under the Committee Pages of the associated codes and standards to provide corrections to incorrectly published items, or to correct typographical or grammatical errors in codes and standards. Such errata shall be used on the date posted.

The B31 Committee Page can be found at <http://go.asme.org/B31committee>. The associated B31 Committee Pages for each code and standard can be accessed from this main page. There is an option available to automatically receive an e-mail notification when errata are posted to a particular code or standard. This option can be found on the appropriate Committee Page after selecting "Errata" in the "Publication Information" section.

ASME is the registered trademark of The American Society of Mechanical Engineers.

This international code or standard was developed under procedures accredited as meeting the criteria for American National Standards and it is an American National Standard. The Standards Committee that approved the code or standard was balanced to assure that individuals from competent and concerned interests have had an opportunity to participate. The proposed code or standard was made available for public review and comment that provides an opportunity for additional public input from industry, academia, regulatory agencies, and the public-at-large.

ASME does not "approve," "rate," or "endorse" any item, construction, proprietary device, or activity.

ASME does not take any position with respect to the validity of any patent rights asserted in connection with any items mentioned in this document, and does not undertake to insure anyone utilizing a standard against liability for infringement of any applicable letters patent, nor assume any such liability. Users of a code or standard are expressly advised that determination of the validity of any such patent rights, and the risk of infringement of such rights, is entirely their own responsibility.

Participation by federal agency representative(s) or person(s) affiliated with industry is not to be interpreted as government or industry endorsement of this code or standard.

ASME accepts responsibility for only those interpretations of this document issued in accordance with the established ASME procedures and policies, which precludes the issuance of interpretations by individuals.

No part of this document may be reproduced in any form,  
in an electronic retrieval system or otherwise,  
without the prior written permission of the publisher.

The American Society of Mechanical Engineers  
Two Park Avenue, New York, NY 10016-5990

Copyright © 2019 by  
THE AMERICAN SOCIETY OF MECHANICAL ENGINEERS  
All rights reserved  
Printed in U.S.A.

# CONTENTS

Foreword .....		vii
Committee Roster .....		ix
Correspondence With the B31 Committee .....		xi
Introduction .....		xiii
Summary of Changes .....		xv
<b>Chapter I</b>	<b>Scope and Definitions .....</b>	<b>1</b>
400	General Statements .....	1
<b>Chapter II</b>	<b>Design .....</b>	<b>11</b>
401	Loads .....	11
402	Calculation of Stresses .....	13
403	Criteria for Pipelines .....	18
404	Criteria for Fittings, Assemblies, and Other Components (Alternatively, Criteria for Components) .....	24
<b>Chapter III</b>	<b>Materials .....</b>	<b>37</b>
423	Materials — General Requirements .....	37
425	Materials Applied to Miscellaneous Parts .....	38
<b>Chapter IV</b>	<b>Dimensional Requirements .....</b>	<b>41</b>
426	Dimensional Requirements for Standard and Nonstandard Piping Components .....	41
<b>Chapter V</b>	<b>Construction, Welding, and Assembly .....</b>	<b>43</b>
434	Construction .....	43
435	Assembly of Piping Components .....	55
<b>Chapter VI</b>	<b>Inspection and Testing .....</b>	<b>57</b>
436	Inspection .....	57
437	Testing .....	58
<b>Chapter VII</b>	<b>Operation and Maintenance Procedures .....</b>	<b>61</b>
450	Operation and Maintenance Procedures Affecting the Safety of Liquid and Slurry Transportation Piping Systems .....	61
451	Pipeline Operation and Maintenance .....	62
452	Pump Station, Terminal, and Storage Facilities Operation and Maintenance .....	71
453	Corrosion Control .....	71
454	Emergency Plan .....	71
455	Records .....	72
456	Qualifying a Piping System for a Higher Operating Pressure .....	72
457	Abandoning a Piping System .....	73
<b>Chapter VIII</b>	<b>Corrosion Control .....</b>	<b>74</b>
460	General .....	74
461	External Corrosion Control for Buried or Submerged Pipelines .....	74
462	Internal Corrosion Control .....	77

463	External Corrosion Control for Pipelines Exposed to Atmosphere . . . . .	78
464	Pipelines in Arctic Environments . . . . .	79
465	Pipelines in High-Temperature Service . . . . .	79
466	External Corrosion Control for Thermally Insulated Pipelines . . . . .	80
467	Stress Corrosion and Other Phenomena . . . . .	81
468	Records . . . . .	81
<b>Chapter IX</b>	<b>Offshore Liquid Pipeline Systems . . . . .</b>	<b>82</b>
A400	General Statements . . . . .	82
A401	Loads . . . . .	83
A402	Calculation of Stresses . . . . .	85
A403	Criteria for Pipelines . . . . .	89
A404	Criteria for Fittings, Assemblies, and Other Components (Alternatively, Criteria for Components) . . . . .	89
A405	Pipe . . . . .	90
A406	Other Design Considerations . . . . .	90
A423	Materials — General Requirements . . . . .	91
A434	Construction . . . . .	91
A436	Inspection . . . . .	92
A437	Testing . . . . .	93
A450	Operation and Maintenance Procedures Affecting the Safety of Liquid and Slurry Transportation Piping Systems . . . . .	93
A451	Pipeline Operation and Maintenance . . . . .	93
A452	Pump Station, Terminal, and Storage Facilities Operation and Maintenance . . . . .	95
A454	Emergency Plan . . . . .	95
A460	General . . . . .	95
A461	External Corrosion Control for Buried or Submerged Pipelines . . . . .	95
A463	External Corrosion Control for Pipelines Exposed to Atmosphere . . . . .	96
<b>Chapter X</b>	<b>Carbon Dioxide Pipeline Systems . . . . .</b>	<b>97</b>
B400	General Statements . . . . .	97
B423	Materials — General Requirements . . . . .	97
B434	Construction . . . . .	97
B437	Testing . . . . .	97
B451	Pipeline Operation and Maintenance . . . . .	98
B454	Emergency Plan . . . . .	98
<b>Chapter XI</b>	<b>Slurry Pipeline Systems . . . . .</b>	<b>99</b>
C400	General Statements . . . . .	99
C401	Loads . . . . .	99
C403	Criteria for Pipelines . . . . .	99
C404	Criteria for Fittings, Assemblies, and Other Components (Alternatively, Criteria for Components) . . . . .	100
C423	Materials — General Requirements . . . . .	100
C426	Dimensional Requirements for Standard and Nonstandard Piping Components . . . . .	100
C434	Construction . . . . .	100
C437	Testing . . . . .	101
C451	Pipeline Operation and Maintenance . . . . .	102
C454	Emergency Plan . . . . .	102

C457	Abandoning a Piping System . . . . .	102
C460	General . . . . .	102
C461	External Corrosion Control for Buried or Submerged Pipelines . . . . .	102
C468	Records . . . . .	102

**Mandatory Appendix**

I	Referenced Standards . . . . .	103
---	--------------------------------	-----

**Nonmandatory Appendices**

A	Submittal of Technical Inquiries to the B31 Pressure Piping Committee . . . . .	107
B	Publications That Do Not Appear in the Code or Mandatory Appendix I but May Be of Informational Benefit . . . . .	108

<b>Index</b>	. . . . .	109
--------------	-----------	-----

**Figures**

400.1.1-1	Diagram Showing Scope of ASME B31.4 Excluding Carbon Dioxide Pipeline Systems (See <a href="#">Figure 400.1.1-2</a> ) . . . . .	3
400.1.1-2	Diagram Showing Scope of ASME B31.4 for Carbon Dioxide Pipeline Systems . . . . .	4
400.1.1-3	Diagram Showing Scope of ASME B31.4 for Slurry Pipeline Systems . . . . .	5
404.3.3.1-1	Reinforced Extruded Outlets . . . . .	27
404.3.4-1	Welding Details for Openings With Complete Encirclement Types of Reinforcement . . . . .	30
404.3.4-2	Welding Details for Openings With Localized-Type Reinforcement . . . . .	31
404.3.4-3	Welding Details for Openings Without Reinforcement Other Than That in Header and Branch Walls . . . . .	32
404.3.5-1	Reinforcement of Branch Connections . . . . .	33
434.8.6-1	Acceptable Butt Welded Joint Design for Equal Wall Thicknesses . . . . .	48
434.8.6-2	Acceptable Butt Welded Joint Design for Unequal Wall Thicknesses . . . . .	49
434.8.6-3	Recommended Attachment Details of Flanges . . . . .	50
451.6.2.2-1	Type I Interaction . . . . .	65
451.6.2.2-2	Type II Interaction . . . . .	65

**Tables**

402.1-1	Flexibility Factor, <i>k</i> , and Stress Intensification Factor, <i>i</i> . . . . .	14
403.2.1-1	Weld Joint Factors Applicable to Common Pipe Specifications . . . . .	19
403.3.1-1	Allowable Values for Pipeline System Stresses . . . . .	20
404.3.4-1	Design Criteria for Welded Branch Connections . . . . .	32
423.1-1	Material Standards and Specifications . . . . .	39
426.1-1	Dimensional Standards . . . . .	42
434.6-1	Minimum Cover for Buried Pipelines . . . . .	45
451.6.2.9-1	Acceptable Pipeline Repair Methods (Nonindented, Nonwrinkled, and Nonbuckled Pipe) . . . . .	69
451.6.2.9-2	Acceptable Pipeline Repair Methods for Dents, Buckles, Ripples, Wrinkles, Leaking Couplings, and Defective Prior Repairs . . . . .	70
A402.3.2-1	Design Factors for Offshore Pipeline Systems . . . . .	87

C423.1-1	Material Standards . . . . .	101
C423.1-2	Material Standards Not Applicable for Slurry Piping Systems From Table 423.1-1 . . . . .	101
C426.1-2	Dimensional Standards Not Applicable for Slurry Piping Systems From Table 426.1-1 . . . . .	101

# FOREWORD

The need for a national code for pressure piping became increasingly evident from 1915 to 1925. To meet this need, the American Engineering Standards Committee [later changed to the American Standards Association (ASA)] initiated Project B31 in March 1926 at the request of The American Society of Mechanical Engineers (ASME), and with that society as sole sponsor. After several years' work by Sectional Committee B31 and its subcommittees, a first edition was published in 1935 as an American Tentative Standard Code for Pressure Piping.

A revision of the original tentative standard was begun in 1937. Several more years' effort was given to securing uniformity between sections and to eliminating divergent requirements and discrepancies, as well as to keeping the code abreast of current developments in welding technique, stress computations, and references to new dimensional and material standards. During this period, a new section was added on refrigeration piping, prepared in cooperation with The American Society of Refrigeration Engineers (ASRE) and complementing the American Standard Code for Mechanical Refrigeration. This work culminated in the 1942 American Standard Code for Pressure Piping.

Supplements 1 and 2 of the 1942 code, which appeared in 1944 and 1947, respectively, introduced new dimensional and material standards, a new formula for pipe wall thickness, and more comprehensive requirements for instrument and control piping. Shortly after the 1942 code was issued, procedures were established for handling inquiries that require explanation or interpretation of code requirements, and for publishing such inquiries and answers in *Mechanical Engineering* for the information of all concerned.

Continuing increases in the severity of service conditions, with concurrent developments of new materials and designs equal to meeting these higher requirements, had pointed to the need by 1948 for more extensive changes in the code than could be provided by supplements alone. The decision was reached by ASA and ASME to reorganize the Sectional Committee and its several subcommittees, and to invite the various interested bodies to reaffirm their representatives or to designate new ones. Following its reorganization, Sectional Committee B31 made an intensive review of the 1942 code, and a revised code was approved and published in February 1951 with the designation ASA B31.1-1951, which included

- (a) a general revision and extension of requirements to agree with practices current at the time
- (b) revision of references to existing dimensional standards and material specifications, and the addition of new references
- (c) clarification of ambiguous or conflicting requirements

Supplement No. 1 to ASA B31.1 was approved and published in 1953 as ASA B31.1a-1953. This Supplement and other approved revisions were included in a new edition published in 1955 with the designation ASA B31.1-1955.

A review by B31 Executive and Sectional Committees in 1955 resulted in a decision to develop and publish industry sections as separate code documents of the American Standard B31 Code for Pressure Piping. ASA B31.4-1959 was the first separate code document for Oil Transportation Piping Systems and superseded that part of Section 3 of ASA B31.1-1955 covering oil transportation piping systems. In 1966, B31.4 was revised to expand coverage on welding, inspection, and testing, and to add new chapters covering construction requirements and operation and maintenance procedures affecting the safety of the piping systems. This revision was published with the designation USAS B31.4-1966, Liquid Petroleum Transportation Piping Systems, since ASA was reconstituted as the United States of America Standards Institute (USASI) in 1966.

USASI changed its name, effective October 6, 1969, to the American National Standards Institute, Inc. (ANSI), and USAS B31.4-1966 was redesignated as ANSI B31.4-1966. The B31 Sectional Committee was redesignated as American National Standards Committee B31 Code for Pressure Piping, and, because of the wide field involved, more than 40 different engineering societies, government bureaus, trade associations, institutes, and the like had one or more representatives on Standards Committee B31, plus a few "Individual Members" to represent general interests. Code activities were subdivided according to the scope of the several sections, and general direction of Code activities rested with Standards Committee B31 officers and an Executive Committee whose membership consisted principally of Standards Committee officers and chairmen of the Section and Technical Specialists Committees.

The ANSI B31.4-1966 Code was revised and published in 1971 with the designation ANSI B31.4-1971.

The ANSI B31.4-1971 Code was revised and published in 1974 with the designation ANSI B31.4-1974.



In December 1978, American National Standards Committee B31 was converted to an ASME Committee with procedures accredited by ANSI. The 1979 revision was approved by ASME and subsequently by ANSI on November 1, 1979, with the designation ANSI/ASME B31.4-1979.

Following publication of the 1979 edition, the B31.4 Section Committee began work on expanding the scope of the Code to cover requirements for the transportation of liquid alcohols. References to existing dimensional standards and material specifications were revised, and new references were added. Other clarifying and editorial revisions were made in order to improve the text. These revisions led to the publication of two addenda to ANSI/ASME B31.4. Addenda “b” was approved and published in 1981 as ANSI/ASME B31.4b-1981. Addenda “c” was approved and published in 1986 as ANSI/ASME B31.4c-1986.

The 1986 edition of ANSI/ASME B31.4 included the two previously published addenda to the 1979 edition.

Following publication of the 1986 edition, clarifying and editorial revisions were made to improve the text. Additionally, references to existing standards and material specifications were revised, and new references were added. These revisions led to the publication of an addenda that was approved and published in 1987 as ASME/ANSI B31.4a-1987.

The 1989 edition of ASME/ANSI B31.4 included the previously published addenda to the 1986 edition.

Following publication of the 1989 edition, clarifying revisions were made to improve the text. Additionally, references to existing standards and material specifications were revised and updated. These revisions led to the publication of an addenda that was approved and published in 1991 as ASME B31.4a-1991.

The 1992 edition of ASME B31.4 included the previously published addenda to the 1989 edition and a revision to valve maintenance. The 1992 edition was approved by ANSI on December 15, 1992, and designated as ASME B31.4-1992 edition.

The 1998 edition of ASME B31.4 included the previously published addenda to the 1992 edition. Also included in the 1998 edition were other revisions and the addition of [Chapter IX](#), Offshore Liquid Pipeline Systems. The 1998 edition was approved by ANSI on November 11, 1998, and designated as ASME B31.4-1998 edition.

The 2002 edition of ASME B31.4 included the previously published addenda to the 1998 edition along with revisions to the maintenance section and updated references. The 2002 edition was approved by ANSI on August 5, 2002, and designated as ASME B31.4-2002.

The 2006 edition of ASME B31.4 contained a new repair section, along with revisions to the definitions section, expansion of material standards Table 423.1 and dimensional standards Table 426.1, and updated references. The 2006 edition was approved by ANSI on January 5, 2006, and designated as ASME B31.4-2006.

The 2009 edition of ASME B31.4 contained major revisions to the definitions section; [Chapter II](#), Design; and [Chapter VIII](#), Corrosion Control. The materials standards Table 423.1 and references were revised and updated. The 2009 edition was approved by ANSI on September 14, 2009, and designated as ASME B31.4-2009.

The 2012 edition of ASME B31.4 contained a revised scope and a new chapter to incorporate the requirements from ASME B31.11, Slurry Transportation Piping Systems. There was also a new chapter for carbon dioxide piping, extracting all of the previous carbon dioxide information into a stand-alone chapter. The definitions section was also revised with new entries. The 2012 edition was approved by ANSI on September 14, 2012, and designated as ASME B31.4-2012.

The 2016 edition of ASME B31.4 contained a revised scope and updates to the stress section in [Chapter II](#). A new paragraph was added in [Chapter III](#) for material requirements in low-temperature applications. In addition, changes were included throughout to reference minimum wall thickness requirements as permitted by manufacturing specifications. The 2016 edition was approved by ANSI on February 22, 2016, and designated as ASME B31.4-2016.

The 2019 edition of ASME B31.4 contains a rework of [Chapter IX](#) to align with standardized numbering of other chapters. A new standard is referenced in [Chapter II](#) to improve the accuracy of calculations that use stress intensification and flexibility factors. Updates to the text and table in [Chapter VI](#) on allowable repairs were completed. The 2019 edition was approved by ANSI on July 18, 2019, and designated as ASME B31.4-2019.

# ASME B31 COMMITTEE

## Code for Pressure Piping

(The following is the roster of the Committee at the time of approval of this Code.)

### STANDARDS COMMITTEE OFFICERS

**J. E. Meyer**, *Chair*  
**J. W. Frey**, *Vice Chair*  
**A. Maslowski**, *Secretary*  
**J. Oh**, *Secretary*

### STANDARDS COMMITTEE PERSONNEL

<b>R. J. T. Appleby</b> , ExxonMobil Pipeline Co.	<b>K. Kaplan</b> , Consultant
<b>K. C. Bodenhamer</b> , TRC Pipeline Services	<b>C. E. Kolovich</b> , Quest Integrity
<b>R. Bojarczuk</b> , ExxonMobil Research and Engineering Co.	<b>A. Maslowski</b> , The American Society of Mechanical Engineers
<b>M. R. Braz</b> , MRBraz & Associates, PLLC	<b>W. J. Mauro</b> , American Electric Power
<b>M. Burkhart</b> , The Burkhart Group, Inc.	<b>J. E. Meyer</b> , CDM Smith — Industrial Division
<b>R. D. Campbell</b> , Bechtel Corp.	<b>T. Monday</b> , Team Industries, Inc.
<b>J. S. Chin</b> , TransCanada Pipeline U.S.	<b>M. L. Nayyar</b> , NICE
<b>D. D. Christian</b> , Victaulic	<b>J. Oh</b> , The American Society of Mechanical Engineers
<b>R. P. Deubler</b> , Becht Engineering Co., Inc.	<b>G. R. Petru</b> , Acapella Engineering Services, LLC
<b>D. Diehl</b> , Hexagon PPM	<b>D. Raho</b> , CCM 2000
<b>M. Engelkemier</b> , Cargill	<b>R. Reamey</b> , Turner Industries Group, LLC
<b>W. H. Eskridge, Jr.</b> , Worley ECR	<b>M. J. Rosenfeld</b> , Kiefner/Applus — RTD
<b>D. J. Fetzner</b> , BP Exploration Alaska, Inc.	<b>J. T. Schmitz</b> , Southwest Gas Corp.
<b>P. D. Flenner</b> , Flenner Engineering Services	<b>S. K. Sinha</b> , Lucius Pitkin, Inc.
<b>J. W. Frey</b> , Joe W. Frey Engineering Services, LLC	<b>W. J. Sperko</b> , Sperko Engineering Services, Inc.
<b>D. R. Frikken</b> , Becht Engineering Co., Inc.	<b>J. P. Swezy, Jr.</b> , Boiler Code Tech, LLC
<b>R. A. Grichuk</b> , S & B Engineers and Constructors, Ltd.	<b>F. W. Tatar</b> , FM Global
<b>R. W. Haupt</b> , Pressure Piping Engineering Associates, Inc.	<b>K. A. Vilminot</b> , Commonwealth Associates, Inc.
<b>L. E. Hayden, Jr.</b> , Consultant	<b>J. S. Willis</b> , Page Southerland Page, Inc.
<b>G. A. Jolly</b> , Samshin Ltd.	

### B31.4 LIQUID AND SLURRY PIPING TRANSPORTATION SYSTEMS SECTION COMMITTEE

<b>C. E. Kolovich</b> , <i>Chair</i> , Quest Integrity	<b>B. Mittelstadt</b> , Dynamic Risk Assessments Systems, Inc.
<b>W. M. Olson</b> , <i>Vice Chair</i> , Gulf Interstate Engineering	<b>A. Morton</b> , Williams Co.
<b>K. Verderber</b> , <i>Secretary</i> , The American Society of Mechanical Engineers	<b>B. Mumme</b> , Koch Pipeline Co.
<b>E. L. Baniak</b> , American Petroleum Institute	<b>G. Newman</b> , U.S. Department of Transportation
<b>A. Baty</b> , Paterson & Cooke USA Ltd.	<b>G. R. Petru</b> , Acapella Engineering Services, LLC
<b>K. C. Bodenhamer</b> , TRC Pipeline Services	<b>T. M. Shie</b> , Shell Pipeline Co., LP
<b>W. M. Cauthen</b> , Tiger Energy Services, Inc.	<b>S. Singh</b> , Bechtel Oil, Gas, and Chemicals, Inc.
<b>R. Duran</b> , Chevron	<b>B. Slater</b> , BP Exploration Alaska, Inc.
<b>S. P. Gade</b> , GIS and SME	<b>D. A. Soenjoto</b> , Plains All American Pipeline
<b>T. Gutierrez</b> , Burrow Global Services, LLC	<b>J. C. Spowart</b> , Bechtel Corp.
<b>E. M. Jorritsma</b> , Shell Projects and Engineering	<b>L. Sweeney</b> , Stantec Consulting
<b>D. B. Kadakia</b> , Consultant	<b>W. L. Trimble</b> , WorleyParsons
<b>P. W. Klein</b> , BHPBilliton	<b>C. Zimmerman</b> , U.S. Department of Transportation
<b>S. Koetting</b> , ExxonMobil Pipeline Co.	<b>M. A. Boring</b> , <i>Contributing Member</i> , DNV GL
<b>Y. Li</b> , Enbridge Pipelines, Inc.	<b>A. Esmaeili</b> , <i>Contributing Member</i> , Origin Energy
<b>S. McKenna</b> , Burns & McDonnell	<b>D. Gilroy</b> , <i>Contributing Member</i> , Bechtel Oil, Gas, and Chemicals, Inc.
<b>T. P. McMahan</b> , DNV GL	<b>R. D. Lewis</b> , <i>Contributing Member</i> , Rosen USA
	<b>D. Moore</b> , <i>Contributing Member</i> , Trout Hydrodynamics, Inc.

## B31 EXECUTIVE COMMITTEE

**J. W. Frey**, *Chair*, Joe W. Frey Engineering Services, LLC  
**R. J. T. Appleby**, ExxonMobil Pipeline Co.  
**M. R. Braz**, MRBraz & Associates, PLLC  
**M. Burkhart**, The Burkhart Group, Inc.  
**R. D. Campbell**, Bechtel Corp.  
**D. D. Christian**, Victaulic  
**R. P. Deubler**, Becht Engineering Co., Inc.  
**D. Diehl**, Hexagon PPM

**D. R. Frikken**, Becht Engineering Co., Inc.  
**L. E. Hayden, Jr.**, Consultant  
**C. E. Kolovich**, Quest Integrity  
**W. J. Mauro**, American Electric Power  
**J. E. Meyer**, CDM Smith — Industrial Division  
**M. L. Nayyar**, NICE  
**S. K. Sinha**, Lucius Pitkin, Inc.

## B31 FABRICATION AND EXAMINATION COMMITTEE

**R. D. Campbell**, *Chair*, Bechtel Corp.  
**U. D'Urso**, *Secretary*, The American Society of Mechanical Engineers  
**D. Bingham**, Los Alamos National Labs  
**B. Boseo**, Graycor Services, LLC  
**M. DeLong**, IHI E&C International Corp.  
**R. Duran**, Chevron  
**R. J. Ferguson**, Metallurgist  
**P. D. Flenner**, Flenner Engineering Services  
**J. W. Frey**, Joe W. Frey Engineering Services, LLC  
**D. R. Frikken**, Becht Engineering Co., Inc.

**S. Gingrich**, AECOM  
**J. Hainsworth**, WR Metallurgical  
**T. Monday**, Team Industries, Inc.  
**A. D. Nalbandian**, Thielsch Engineering, Inc.  
**R. Reamey**, Turner Industries Group, LLC  
**R. J. Silvia**, Process Engineers & Constructors, Inc.  
**W. J. Sperko**, Sperko Engineering Services, Inc.  
**J. P. Swezy, Jr.**, Boiler Code Tech, LLC  
**K. Wu**, Stellar Energy Systems

## B31 MATERIALS TECHNICAL COMMITTEE

**R. P. Deubler**, *Chair*, Becht Engineering Co., Inc.  
**W. H. Eskridge, Jr.**, *Vice Chair*, Worley ECR  
**C. O'Brien**, *Secretary*, The American Society of Mechanical Engineers  
**B. Bounds**, Bechtel Corp.  
**W. P. Collins**, WPC Sol, LLC  
**R. Grichuk**, S & B Engineers and Constructors, Ltd.  
**J. Gundlach**, Michigan Seamless Tube and Pipe  
**A. A. Hassan**, PGESCO  
**L. Henderson, Jr.**, Chiyoda International Corp.

**C. Henley**, Kiewit Engineering Group, Inc.  
**G. A. Jolly**, Samshin Ltd.  
**C. J. Melo**, S & B Engineers and Constructors, Ltd.  
**M. L. Nayyar**, NICE  
**K. Pham**, Fluor Enterprises, Inc.  
**D. W. Rahoji**, CCM 2000  
**R. A. Schmidt**, Canadoil  
**D. K. Verma**, Bechtel Oil Gas and Chemicals, Inc.  
**Z. Djilali**, *Contributing Member*, Sonatrach

## B31 MECHANICAL DESIGN TECHNICAL COMMITTEE

**J. E. Meyer**, *Chair*, CDM Smith — Industrial Division  
**M. Engelkemier**, *Vice Chair*, Cargill  
**R. Rahaman**, *Secretary*, The American Society of Mechanical Engineers  
**G. A. Antaki**, Becht Engineering Co., Inc.  
**D. A. Arnett**, ExxonMobil Research and Engineering  
**C. Becht IV**, Becht Engineering Co., Inc.  
**R. Bethea**, HII — Newport News Shipbuilding  
**J. P. Ellenberger**, Consultant  
**D. J. Fetzner**, BP Exploration Alaska, Inc.  
**D. Fraser**, NASA Ames Research Center  
**J. A. Graziano**, Consultant  
**J. D. Hart**, SSD, Inc.

**R. W. Haupt**, Pressure Piping Engineering Associates, Inc.  
**B. P. Holbrook**, Consultant  
**R. A. Leishear**, Leishear Engineering, LLC  
**G. D. Mayers**, Alion Science & Technology  
**T. Q. McCawley**, TQM Engineering PC  
**P. Moore**, Burns & McDonnell  
**A. Paulin**, Paulin Research Group  
**R. A. Robleto**, KBR  
**M. J. Rosenfeld**, Kiefner/Applus — RTD  
**T. Sato**, Japan Power Engineering and Inspection Corp.  
**M. Stewart**, AECOM  
**J. Minichiello**, *Contributing Member*, Bechtel National, Inc.

# CORRESPONDENCE WITH THE B31 COMMITTEE

(19)

**General.** ASME Standards are developed and maintained with the intent to represent the consensus of concerned interests. As such, users of this Code may interact with the Committee by requesting interpretations, proposing revisions or a case, and attending Committee meetings. Correspondence should be addressed to:

Secretary, B31 Standards Committee  
The American Society of Mechanical Engineers  
Two Park Avenue  
New York, NY 10016-5990  
<http://go.asme.org/Inquiry>

**Proposing Revisions.** Revisions are made periodically to the Code to incorporate changes that appear necessary or desirable, as demonstrated by the experience gained from the application of the Code. Approved revisions will be published periodically.

The Committee welcomes proposals for revisions to this Code. Such proposals should be as specific as possible, citing the paragraph number(s), the proposed wording, and a detailed description of the reasons for the proposal, including any pertinent documentation.

**Proposing a Case.** Cases may be issued to provide alternative rules when justified, to permit early implementation of an approved revision when the need is urgent, or to provide rules not covered by existing provisions. Cases are effective immediately upon ASME approval and shall be posted on the ASME Committee web page.

Requests for Cases shall provide a Statement of Need and Background Information. The request should identify the Code and the paragraph, figure, or table number(s), and be written as a Question and Reply in the same format as existing Cases. Requests for Cases should also indicate the applicable edition(s) of the Code to which the proposed Case applies.

**Interpretations.** Upon request, the B31 Standards Committee will render an interpretation of any requirement of the Code. Interpretations can only be rendered in response to a written request sent to the Secretary of the B31 Standards Committee.

Requests for interpretation should preferably be submitted through the online Interpretation Submittal Form. The form is accessible at <http://go.asme.org/InterpretationRequest>. Upon submittal of the form, the Inquirer will receive an automatic e-mail confirming receipt.

If the Inquirer is unable to use the online form, he/she may mail the request to the Secretary of the B31 Standards Committee at the above address. The request for an interpretation should be clear and unambiguous. It is further recommended that the Inquirer submit his/her request in the following format:

- Subject: Cite the applicable paragraph number(s) and the topic of the inquiry in one or two words.
- Edition: Cite the applicable edition of the Code for which the interpretation is being requested.
- Question: Phrase the question as a request for an interpretation of a specific requirement suitable for general understanding and use, not as a request for an approval of a proprietary design or situation. Please provide a condensed and precise question, composed in such a way that a "yes" or "no" reply is acceptable.
- Proposed Reply(ies): Provide a proposed reply(ies) in the form of "Yes" or "No," with explanation as needed. If entering replies to more than one question, please number the questions and replies.
- Background Information: Provide the Committee with any background information that will assist the Committee in understanding the inquiry. The Inquirer may also include any plans or drawings that are necessary to explain the question; however, they should not contain proprietary names or information.

Requests that are not in the format described above may be rewritten in the appropriate format by the Committee prior to being answered, which may inadvertently change the intent of the original request.

Moreover, ASME does not act as a consultant for specific engineering problems or for the general application or understanding of the Code requirements. If, based on the inquiry information submitted, it is the opinion of the Committee that the Inquirer should seek assistance, the inquiry will be returned with the recommendation that such assistance be obtained.

ASME procedures provide for reconsideration of any interpretation when or if additional information that might affect an interpretation is available. Further, persons aggrieved by an interpretation may appeal to the cognizant ASME Committee or Subcommittee. ASME does not “approve,” “certify,” “rate,” or “endorse” any item, construction, proprietary device, or activity.

**Attending Committee Meetings.** The B31 Standards Committee regularly holds meetings and/or telephone conferences that are open to the public. Persons wishing to attend any meeting and/or telephone conference should contact the Secretary of the B31 Standards Committee.

# INTRODUCTION

The ASME B31 Code for Pressure Piping consists of a number of individually published Sections, each an American National Standard. Rules for each Section reflect the kinds of piping installations considered during its development, as follows:

- B31.1 Power Piping: piping typically found in electric power-generating stations, industrial and institutional plants, geothermal heating systems, and central and district heating and cooling systems
- B31.3 Process Piping: piping typically found in petroleum refineries; onshore and offshore petroleum and natural gas production facilities; chemical, pharmaceutical, textile, paper, ore processing, semiconductor, and cryogenic plants; food and beverage processing facilities; and related processing plants and terminals
- B31.4 Pipeline Transportation Systems for Liquids and Slurries: piping transporting hazardous products that are predominately liquid between facilities, production and storage fields, plants, and terminals, and within terminals and pumping, regulating, and metering stations associated with liquid pipeline systems
- B31.5 Refrigeration Piping and Heat Transfer Components: piping for refrigerants and secondary coolants
- B31.8 Gas Transmission and Distribution Piping Systems: piping transporting products that are predominately gas between sources and terminals, including compressor, regulating, and metering stations, and gas gathering pipelines
- B31.9 Building Services Piping: piping typically found in industrial, institutional, commercial, and public buildings, and in multi-unit residences, that does not require the range of sizes, pressures, and temperatures covered in B31.1
- B31.12 Hydrogen Piping and Pipelines: piping in gaseous and liquid hydrogen service and pipelines in gaseous hydrogen service

This is Code Section B31.4, Pipeline Transportation Systems for Liquids and Slurries. Hereafter, in this Introduction and in the text of this Code Section B31.4, where the word “Code” is used without specific identification, it means this Code Section.

It is the user’s responsibility to select the Code Section that most nearly applies to a proposed piping installation. Factors to be considered include limitations of the Code Section, jurisdictional requirements, and the applicability of other codes and standards. All applicable requirements of the selected Code Section shall be met. For some installations, more than one Code Section may apply to different parts of the installation. Certain piping within a facility may be subject to other national or industry codes and standards. The user is also responsible for imposing requirements supplementary to those of the Code if necessary to ensure safe piping for the proposed installation.

The Code specifies engineering requirements deemed necessary for safe design, construction, operation, and maintenance of pressure piping. While safety is the primary consideration, this factor alone will not necessarily govern the final specifications for any piping installation or operation. The Code is not a design handbook. Many decisions that must be made to produce a sound piping installation and to maintain system integrity during operation are not specified in detail within this Code. The Code does not serve as a substitute for sound engineering judgments by the operating company and the designer.

To the greatest possible extent, Code requirements for design are stated in terms of basic design principles and formulas. These are supplemented as necessary with specific requirements to ensure uniform application of principles and to guide selection and application of piping elements. The Code prohibits designs and practices known to be unsafe and contains warnings where caution, but not prohibition, is warranted.

This Code Section includes

- (a) references to acceptable material specifications and component standards, including dimensional requirements and pressure-temperature ratings
- (b) requirements for design of components and assemblies, including pipe supports
- (c) requirements and data for evaluation and limitation of stresses, reactions, and movements associated with pressure, temperature changes, and other forces
- (d) guidance and limitations on the selection and application of materials, components, and joining methods

- (e) requirements for the fabrication, assembly, and erection of piping
- (f) requirements for examination, inspection, and testing of piping
- (g) procedures for operation and maintenance that are essential to public safety
- (h) provisions for protecting pipelines from external corrosion and internal corrosion/erosion

It is intended that this edition of Code Section B31.4 not be retroactive. Unless agreement is specifically made between contracting parties to use another edition, or the regulatory body having jurisdiction imposes the use of another edition, the latest edition issued at least 6 months prior to the original contract date for the first phase of activity covering a piping system or systems shall be the governing document for all design, materials, fabrication, erection, examination, and testing for the piping until the completion of the work and initial operation.

Users of this Code are cautioned against making use of Code revisions without assurance that they are acceptable to the proper authorities in the jurisdiction where the piping is to be installed.

Code users will note that paragraphs in the Code are not necessarily numbered consecutively. Such discontinuities result from following a common outline, insofar as practicable, for all Code Sections. In this way, corresponding material is correspondingly numbered in most Code Sections, thus facilitating reference by those who have occasion to use more than one Section.

The Code is under the direction of ASME Committee B31, Code for Pressure Piping, which is organized and operates under procedures of The American Society of Mechanical Engineers that have been accredited by the American National Standards Institute. The Committee is a continuing one and keeps all Code Sections current with new developments in materials, construction, and industrial practice. New editions are published at intervals of 3 to 5 years.

When no Section of the ASME Code for Pressure Piping specifically covers a piping system, at his discretion the user may select any Section determined to be generally applicable. However, it is cautioned that supplementary requirements to the Section chosen may be necessary to provide for a safe piping system for the intended application. Technical limitations of the various Sections, legal requirements, and possible applicability of other codes or standards are some of the factors to be considered by the user in determining the applicability of any Section of this Code.

The Committee has established an orderly procedure to consider requests for interpretation and revision of Code requirements. To receive consideration, inquiries must be in writing and must give full particulars (see [Correspondence With the B31 Committee](#) covering preparation of technical inquiries).

The approved reply to an inquiry will be sent directly to the inquirer. In addition, the question and reply will be published on the ASME Interpretations Database.

A Case is the prescribed form of reply to an inquiry when study indicates that the Code wording needs clarification or when the reply modifies existing requirements of the Code or grants permission to use new materials or alternative constructions. The Case will be published on the B31.4 web page at <http://cstools.asme.org/>.

A Case is normally issued for a limited period, after which it may be renewed, incorporated in the Code, or allowed to expire if there is no indication of further need for the requirements covered by the Case. However, the provisions of a Case may be used after its expiration or withdrawal, provided the Case was effective on the original contract date or was adopted before completion of the work, and the contracting parties agree to its use.

Materials are listed in the stress tables only when sufficient usage in piping within the scope of the Code has been shown. Materials may be covered by a Case. Requests for listing shall include evidence of satisfactory usage and specific data to permit establishment of allowable stresses, maximum and minimum temperature limits, and other restrictions. Additional criteria can be found in the guidelines for addition of new materials in the ASME Boiler and Pressure Vessel Code, Section II and Section VIII, Division 1, Appendix B. (To develop usage and gain experience, unlisted materials may be used in accordance with [para. 423.1.](#))

# ASME B31.4-2019 SUMMARY OF CHANGES

Following approval by the ASME B31 Committee and ASME, and after public review, ASME B31.4-2019 was approved by the American National Standards Institute on July 18, 2019.

ASME B31.4-2019 includes the following changes identified by a margin note, **(19)**.

<i>Page</i>	<i>Location</i>	<i>Change</i>
xi	Correspondence With the B31 Committee	Added
2	400.1.1	(1) Subparagraph (b) added, and remaining subparagraphs redesignated (2) Subparagraphs (d) and (e) [formerly (c) and (d)] revised
13	402.1	Second paragraph revised
17	402.5.2	(1) Note designation deleted (2) Nomenclature revised
17	402.6.1	Definition of <i>A</i> revised
17	402.6.2	Definition of <i>A</i> and final paragraph revised
18	403.2.1	(1) Equation and nomenclature revised (2) Final paragraph deleted
23	403.9.1	Note added
24	404.1.2	Revised
25	404.2.3	Final paragraph revised
33	Figure 404.3.5-1	(1) Definition of <i>L</i> removed from figure and added to the nomenclature (2) Nomenclature revised
33	404.4.1	First paragraph revised
34	404.5.1	Final paragraph revised
36	404.11	First paragraph revised
38	425	Revised in its entirety
39	Table 423.1-1	Title revised
41	426.3	Revised
43	434.2.2	Revised
43	434.4	Revised
44	434.7.1	Subparagraph (a) revised
45	434.8.2	Subparagraph (a) revised
47	434.8.9	Subparagraph (a) revised
51	434.13.5	Subparagraph (b) revised
52	434.15.2	Subparagraph (f) added
53	434.18	Subparagraph (b)(1) revised
56	435.4.3	Revised
59	437.4.1	Subparagraph (a) revised



<i>Page</i>	<i>Location</i>	<i>Change</i>
59	437.4.3	Revised
59	437.6.4	Revised
62	451.6.1	Subparagraph (g) revised
65	451.6.2.6	First paragraph revised
66	451.6.2.9	First paragraph and subparas. (b) and (d) revised
68	451.9	Subparagraph (a) revised
69	Table 451.6.2.9-1	Entry in sixth row of fourth column revised
71	452.7	Subparagraph (d) revised
74	461.1.2	Subparagraphs (a) and (b) revised
75	461.1.7	Final sentence revised
77	462.1	Final sentence revised
77	462.2	Subparagraph (g)(1) revised
78	462.3	Subparagraphs (b)(1), (b)(2), (b)(3), (b)(5), (b)(6), and (b)(7) revised
78	463.1	Subparagraph (b) revised
80	466.1.1	Second and third paragraphs revised
81	467	Final sentence revised
82	A400	Subparagraph (d) revised
83	A401	Revised in its entirety
85	A402	Revised in its entirety
89	A403	Revised in its entirety
90	A404.4.3	(1) Redesignated from original A404.4.1 (2) Title revised
90	A404.8.3	Revised
90	A405	A405.1(a) and A405.2 revised
90	A406.3	Former A421 revised and redesignated as A406.3
91	A423.2	Final sentence revised
91	A434.2.2	Former A434.2 redesignated as A434.2.2
91	A434.8	Titles of A434.8.3, A434.8.5, A434.8.5(a), and A434.8.5(b) revised
92	A434.13.1	Revised
92	A434.25	(1) Former A434.14 redesignated as A434.25 (2) Cross-references updated
92	A436.5.1	(1) Subparagraphs (9), (11), (12), (13), and (15) redesignated as (19) through (23) (2) Subparagraph (23) [formerly (15)] revised
93	A451.3	Title revised
93	A451.5	Final sentence deleted
94	A451.6	Final paragraph added
94	A451.6.2	Revised in its entirety
94	A451.10	Title revised
95	A460	Subparagraph (c) revised
95	A461	(1) Titles of A461, A461.1.2, A461.1.3, and A461.1.5 revised (2) A461.1.1(c) redesignated as A461.1.1(a) (3) In A461.3, subparagraphs redesignated, and reference updated

<i>Page</i>	<i>Location</i>	<i>Change</i>
96	A463.2	Former A463.1 redesignated as A463.2
99	C400.2	Definition of <i>ductile iron</i> revised
100	C404.4.1	Revised
103	Mandatory Appendix I	Updated
107	Nonmandatory Appendix A	Information moved to Correspondence With the B31 Committee page
109	Index	Updated

INTENTIONALLY LEFT BLANK

# Chapter I

## Scope and Definitions

### 400 GENERAL STATEMENTS

(a) This pipeline transportation systems Code is one of several sections of The American Society of Mechanical Engineers Code for Pressure Piping, ASME B31, and it is the responsibility of the user of this Code to select the applicable Section. This Section is published as a separate document for convenience. This Code is intended to apply to pipeline systems transporting liquids including, but not limited to, crude oil, condensate, liquid petroleum products, natural gasoline, natural gas liquids, liquefied petroleum gas, carbon dioxide (supercritical), liquid alcohol, liquid anhydrous ammonia, produced water, injection water, brine, biofuels, and slurries. Throughout this Code, these systems will be referred to as liquid pipeline systems.

(b) The requirements of this Code are adequate for safety under conditions normally encountered in the operation of liquid pipeline systems. Requirements for all abnormal or unusual conditions are not specifically provided for, nor are all details of engineering and construction prescribed. All work performed within the scope of this Code shall comply with the safety standards expressed or implied.

(c) The primary purpose of this Code is to establish requirements for safe design, construction, inspection, testing, operation, and maintenance of liquid pipeline systems for protection of the general public and operating company personnel, as well as for reasonable protection of the piping system against vandalism and accidental damage by others, and reasonable protection of the environment.

(d) This Code is concerned with employee safety to the extent that it is affected by basic design, quality of materials and workmanship, and requirements for construction, inspection, testing, operation, and maintenance of liquid pipeline systems. Existing industrial safety regulations pertaining to work areas, safe work practices, and safety devices are not intended to be supplanted by this Code.

(e) The designer is cautioned that the Code is not a design handbook. The Code does not do away with the need for the engineer or competent engineering judgment. The Code generally employs a simplified approach for many of its requirements.

(1) For design and construction, a designer may choose to use a more complete and rigorous analysis to develop design and construction requirements. When the designer decides to take this approach, the designer shall provide details and calculations demonstrating design, construction, examination, and testing are consistent with the criteria of this Code. These details shall be adequate for the operating company to verify the validity of the approach and shall be approved by the operating company. The details shall be documented in the engineering design.

(2) For operation and maintenance, the operating company may choose to use a more rigorous analysis to develop operation and maintenance requirements. When the operating company decides to take this approach, the operating company shall provide details and calculations demonstrating that such alternative practices are consistent with the objectives of this Code. The details shall be documented in the operating records and retained for the lifetime of the facility.

(f) This Code shall not be retroactive or construed as applying to piping systems installed before the date of issuance shown on the document title page insofar as design, materials, construction, assembly, inspection, and testing are concerned. It is intended, however, that the provisions of this Code shall be applicable within 6 months after date of issuance to the relocation, replacement, and uprating or otherwise changing of existing piping systems; and to the operation, maintenance, and corrosion control of new or existing piping systems. After Code revisions are approved by ASME and ANSI, they may be used by agreement between contracting parties beginning with the date of issuance. Revisions become mandatory or minimum requirements for new installations 6 months after date of issuance except for piping installations or components contracted for or under construction prior to the end of the 6-month period.

(g) The users of this Code are advised that in some areas legislation may establish governmental jurisdiction over the subject matter covered by this Code and are cautioned against making use of revisions that are less restrictive than former requirements without having assurance that they have been accepted by the proper authorities in the jurisdiction where the piping is to be installed. The Department of Transportation, United States of America, rules governing the transportation

by pipeline in interstate and foreign commerce of petroleum, petroleum products, and liquids such as anhydrous ammonia or carbon dioxide are prescribed under Part 195 — Transportation of Hazardous Liquids by Pipeline, Title 49 — Transportation, Code of Federal Regulations.

#### 400.1 Scope

- (19) **400.1.1** This Code prescribes requirements for the design, materials, construction, assembly, inspection, testing, operation, and maintenance of liquid pipeline systems between production fields or facilities, tank farms, above- or belowground storage facilities, natural gas processing plants, refineries, pump stations, ammonia plants, terminals (marine, rail, and truck), and other delivery and receiving points, as well as pipelines transporting liquids within pump stations, tank farms, and terminals associated with liquid pipeline systems (see [Figures 400.1.1-1](#) and [400.1.1-2](#)).

This Code also prescribes requirements for the design, materials, construction, assembly, inspection, testing, operation, and maintenance of piping transporting aqueous slurries of nonhazardous materials such as coal, mineral ores, concentrates, and other solid materials, between a slurry processing plant or terminal and a receiving plant or terminal (see [Figure 400.1.1-3](#)).

Piping consists of pipe, flanges, bolting, gaskets, valves, relief devices, fittings, and the pressure-containing parts of other piping components. It also includes hangers and supports, and other equipment items necessary to prevent overstressing the pressure-containing parts. It does not include support structures such as frames of buildings, stanchions, or foundations, or any equipment such as defined in [para. 400.1.2\(b\)](#).

Requirements for offshore pipelines are found in [Chapter IX](#). Requirements for carbon dioxide pipelines are found in [Chapter X](#). Requirements for slurry pipelines are found in [Chapter XI](#).

Also included within the scope of this Code are

(a) primary and associated auxiliary liquid petroleum and liquid anhydrous ammonia piping at pipeline terminals (marine, rail, and truck), tank farms, pump stations, pressure-reducing stations, and metering stations, including scraper traps, strainers, and prover loops

(b) primary and auxiliary slurry piping at storage facilities, pipeline terminals, pump stations, choke stations, and pressure-reducing stations, including piping up to the first valve of attached auxiliary water lines

(c) storage and working tanks, including pipe-type storage fabricated from pipe and fittings, and piping interconnecting these facilities

(d) liquid petroleum, liquid anhydrous ammonia, and slurry piping located on property that has been designated for such piping within petroleum refinery, natural gasoline, gas processing, ammonia, bulk plants, and slurry transportation systems

(e) those aspects of operation and maintenance of liquid and slurry pipeline systems relating to the safety and protection of the general public, operating company personnel, environment, property, and the piping systems [see [paras. 400\(c\)](#) and [400\(d\)](#)]

**400.1.2** This Code was not developed to apply to

(a) building service piping, such as water, air, or steam  
(b) pressure vessels, heat exchangers, pumps, meters, and other such equipment, including internal piping and connections for piping except as limited by [para. 423.2.4\(b\)](#)

(c) piping with a design temperature below  $-20^{\circ}\text{F}$  ( $-30^{\circ}\text{C}$ ) or above  $250^{\circ}\text{F}$  ( $120^{\circ}\text{C}$ ) [for applications below  $-20^{\circ}\text{F}$  ( $-30^{\circ}\text{C}$ ), see [paras. 423.2.1\(a\)](#) and [423.2.6](#)]

(d) casing, tubing, or pipe used in oil wells and wellhead assemblies

#### 400.2 Definitions

Some of the more common terms relating to piping are defined below. For welding terms used in this Code but not shown here, definitions in accordance with AWS A3.0 apply.

*accidental loads*: any unplanned load or combination of unplanned loads caused by human intervention or natural phenomena.

*active corrosion*: corrosion that is continuing or not arrested.

*anomaly*: an indication, detected by nondestructive examination (such as in-line inspection).

*arc welding (AW)*<sup>1</sup>: a group of welding processes that produces coalescence of workpieces by heating them with an arc. The processes are used with or without the application of pressure and with or without filler metal.

*automatic welding*<sup>1</sup>: welding with equipment that requires only occasional or no observation of the welding, and no manual adjustment of the equipment controls.

*backfill*: material placed in a hole or trench to fill excavated space around a pipeline.

*blunt imperfection*: an imperfection characterized by smoothly contoured variations in wall thickness.<sup>2</sup>

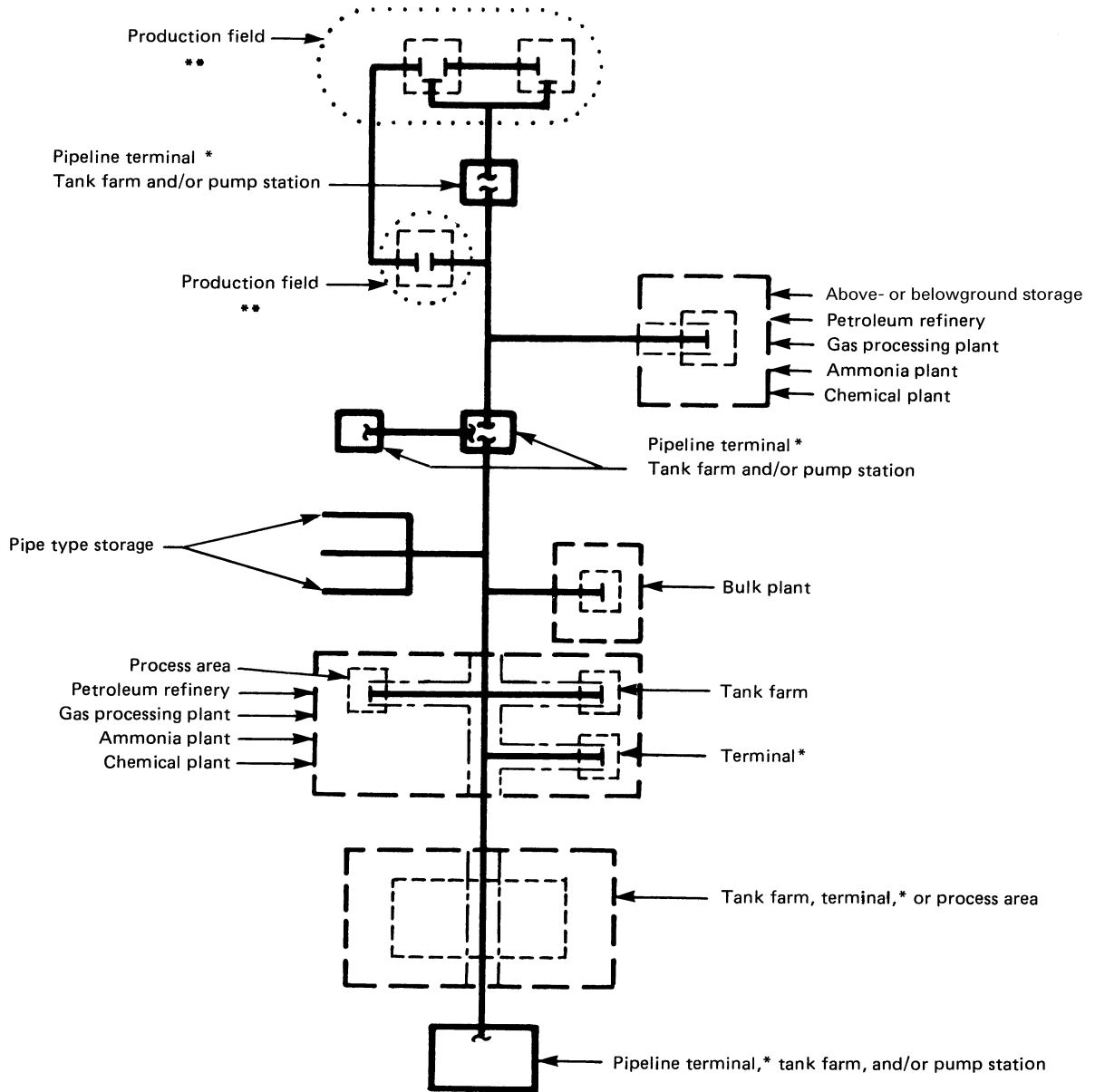
*breakaway coupling*: a component installed in the pipeline to allow the pipeline to separate when a predetermined axial load is applied to the coupling.

*buckle*: a condition where the pipeline has undergone sufficient plastic deformation to cause permanent wrinkling in the pipe wall or excessive cross-sectional

<sup>1</sup> These welding terms agree with AWS A3.0.

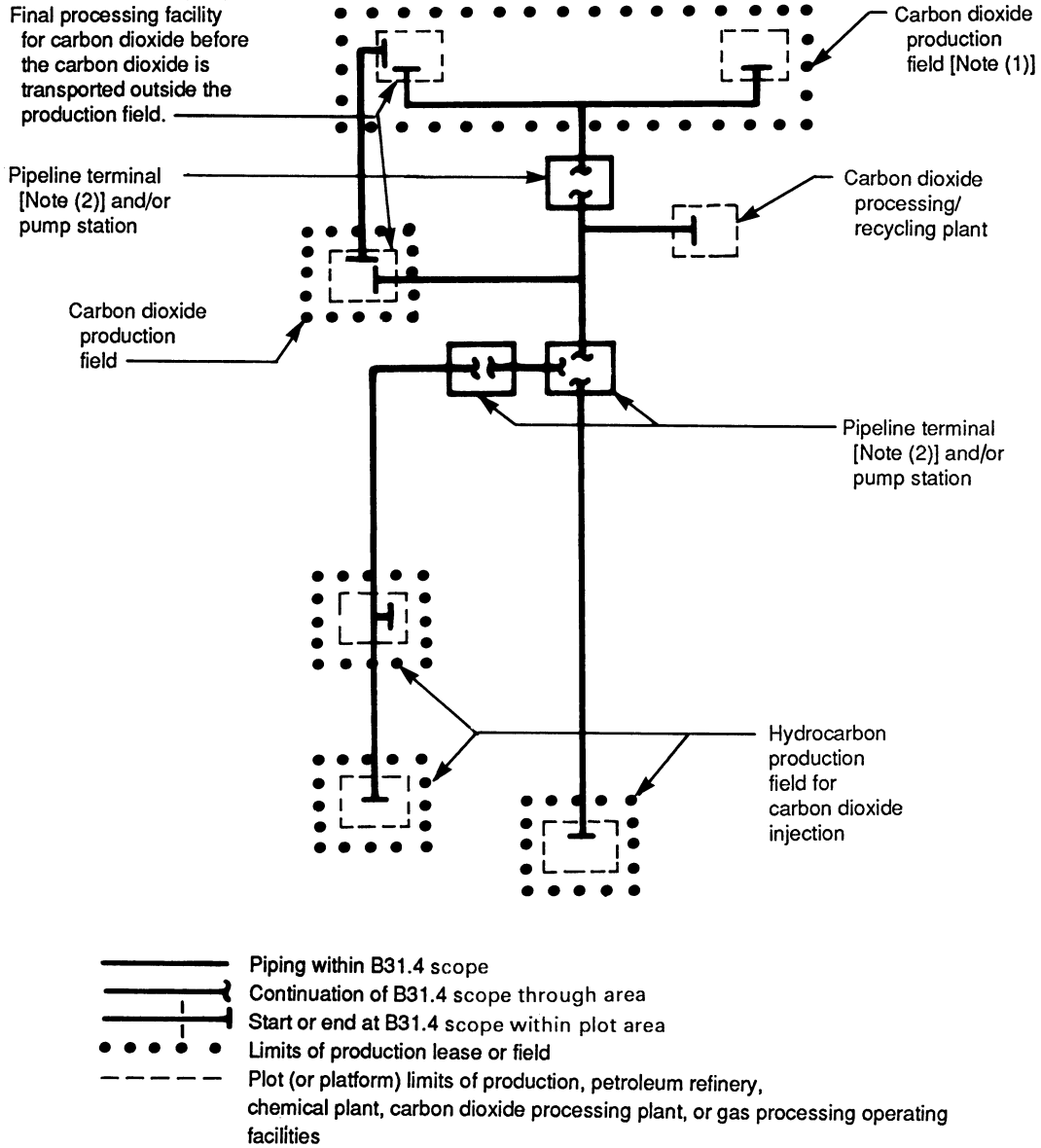
<sup>2</sup> Sharp imperfections may be rendered blunt by grinding, but the absence of a sharp imperfection must be verified by visual and nondestructive examination.

**Figure 400.1.1-1 Diagram Showing Scope of ASME B31.4 Excluding Carbon Dioxide Pipeline Systems**  
 (See [Figure 400.1.1-2](#))



- \* Marine, rail, or truck (all loading or unloading)
- \*\* Onshore or offshore
- Piping within B31.4 scope
- > Continuation of B31.4 scope through area
- | Start or end at B31.4 scope within plot area
- ..... Limits of production lease or field
- - - - - Plot (or platform) limits of production, petroleum refinery, chemical plant, ammonia plant, bulk plant, or gas processing operating facilities
- - - - - Corridor within property of petroleum refinery, chemical plant, ammonia plant, or gas processing plant set aside for B31.4 piping
- Property line of petroleum refinery, chemical plant, ammonia plant, gas processing plant, or bulk plant

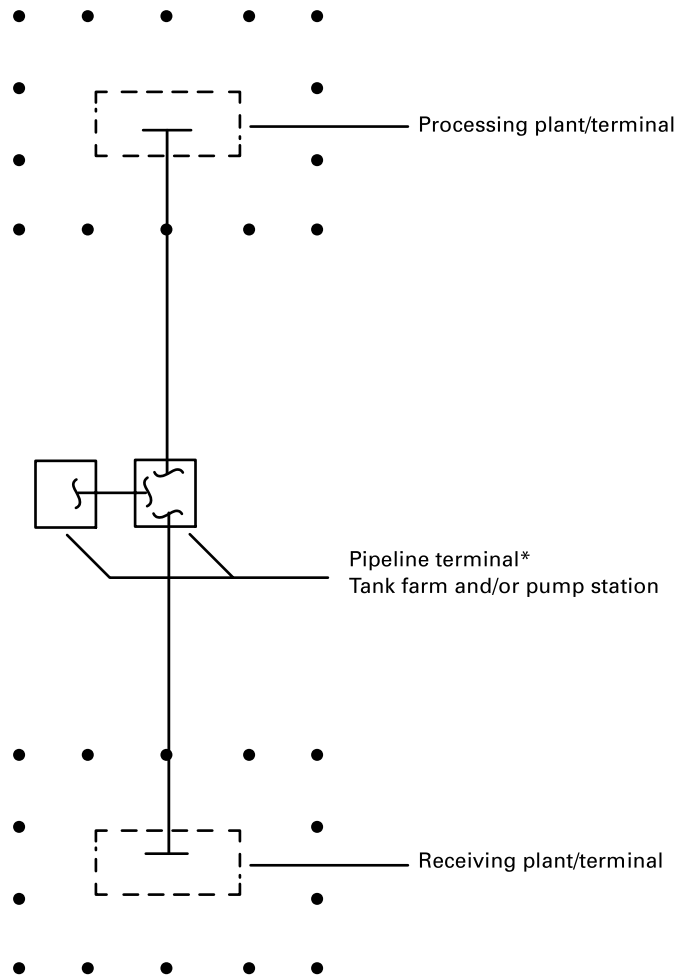
Figure 400.1.1-2 Diagram Showing Scope of ASME B31.4 for Carbon Dioxide Pipeline Systems



(1) Onshore or offshore.

(2) Marine, rail, or truck (all loading or unloading).

Figure 400.1.1-3 Diagram Showing Scope of ASME B31.4 for Slurry Pipeline Systems



- \* Marine, rail, or truck (all loading or unloading)
- Piping within B31.4 scope
- ⌋ Continuation of B31.4 scope through area
- ⌋ Start or end at B31.4 scope within plot area
- Plot limits of processing plant or receiving plant
- Property line of processing plant or receiving plant



deformation caused by loads acting alone or in combination with hydrostatic pressure.

*butt weld (typically, a butt joint, single V-groove weld):* a weld between two members aligned approximately in the same plane.

*cathodic protection (CP):* technique to reduce the corrosion of a metal surface by making that surface the cathode of an electrochemical cell.

*characterize:* to quantify the type, size, shape, orientation, and location of an anomaly.

*coating:* liquid, liquefiable, or mastic composition that, after application to a surface, is converted into a solid protective or functional adherent film. Coating also includes tape wrap.

*coating system:* complete number and types of coats applied to a surface in a predetermined order. (When used in a broader sense, surface preparation, pretreatments, dry film thickness, and manner of application are included.)

*cold springing:* deliberate deflection of piping, within its yield strength, to compensate for anticipated thermal expansion.

*column buckling:* buckling of a beam or pipe under compressive axial load in which loads cause unstable lateral deflection; also referred to as upheaval buckling.

*component:* an individual item or element fitted in line with pipe in a pipeline system, such as, but not limited to, valves, elbows, tees, flanges, and closures.

*connectors:* components, except flanges, used for the purpose of mechanically joining two sections of pipe.

*consequence:* impact that a pipeline failure could have on the public, employees, property, and the environment.

*corrosion:* deterioration of a material, usually a metal, that results from a reaction with its environment.

*corrosion inhibitor:* chemical substance or combination of substances that, when present in the environment or on a surface, prevents or reduces corrosion.

*defect<sup>1</sup>:* a discontinuity or discontinuities that by nature or accumulated effect render a part or product unable to meet minimum applicable acceptance standards or specifications. The term designates rejectability.

*dent:* permanent concave deformation of the circular cross section of the pipe that produces a decrease in the diameter.

*design life:* a period of time used in design calculations, selected for the purpose of verifying that a replaceable or permanent component is suitable for the anticipated period of service. Design life does not pertain to the life of the pipeline system because a properly maintained and protected pipeline system can provide liquid transportation service indefinitely.

*detect:* to sense or obtain measurable indications from an anomaly or coating flaw in a pipeline using in-line inspection or other technologies.

*discontinuity<sup>1</sup>:* an interruption of the typical structure of a material, such as a lack of homogeneity in its mechanical, metallurgical, or physical characteristics. A discontinuity is not necessarily a defect.

*ductility:* measure of the capability of a material to be deformed plastically before fracturing.

*electrolyte:* a chemical substance containing ions that migrate in an electric field. For purposes of this Code, electrolytes include the soil or liquid adjacent to and in contact with a buried or submerged metallic piping system, as well as some transported liquid products.

*employer:* the owner, manufacturer, fabricator, contractor, assembler, or installer responsible for the welding, brazing, and NDE performed by his organization, including procedure and performance qualifications.

*engineering design:* detailed design developed from operating requirements and conforming to Code requirements, including all necessary drawings and specifications, governing a piping installation.

*environment:* surroundings or conditions (physical, chemical, or mechanical) in which a material exists.

*epoxy:* type of resin formed by the reaction of aliphatic or aromatic polyols (like bisphenol) with epichlorohydrin and characterized by the presence of reactive oxirane end groups.

*evaluation:* a review, following the characterization of an actionable anomaly, to determine whether the anomaly meets specified acceptance criteria.

*examination:* direct physical inspection of a pipeline which may include the use of nondestructive examination (NDE) techniques or methods.

*experience:* work activities accomplished in a specific NDT method under the direction of qualified supervision, including the performance of the NDT method and related activities, but not including time spent in organized training programs.

*failure:* general term used to imply that a part in service has become completely inoperable; is still operable but is incapable of satisfactorily performing its intended function; or has deteriorated seriously to the point that it has become unreliable or unsafe for continued use.

*fatigue:* process of development of or enlargement of a crack as a result of repeated cycles of stress.

*fillet weld<sup>1</sup>:* a weld of approximately triangular cross section joining two surfaces approximately at right angles to each other in a lap joint, tee joint, or corner joint.

*film:* thin, not necessarily visible layer of material.

*full fillet weld*<sup>1</sup>: a fillet weld whose size is equal to the thickness of the thinner member joined.

*gas metal arc welding (GMAW)*<sup>1</sup>: an arc welding process that uses an arc between a continuous filler metal electrode and the weld pool. The process is used with shielding from an externally supplied gas and without the application of pressure.

*gas tungsten arc welding (GTAW)*<sup>1</sup>: an arc welding process that uses an arc between a tungsten electrode (nonconsumable) and the weld pool. The process is used with shielding gas and without the application of pressure.

*general corrosion*: uniform or gradually varying loss of wall thickness over an area.

*girth weld*: a complete circumferential butt weld joining pipe or components.

*gouge*: mechanically induced metal loss, which causes localized elongated grooves or cavities in a metal pipeline.

*hydrostatic test or hydrotest*: a pressure test using water as the test medium.

*imperfection*: discontinuity or irregularity that is detected by inspection.

*incident*: unintentional release of liquid due to the failure of a pipeline.

*inclusion*: nonmetallic phase such as an oxide, sulfide, or silicate particle in a metal pipeline.

*indication*: finding from a nondestructive testing technique or method that deviates from the expected. It may or may not be a defect.

*in-line inspection (ILI)*: steel pipeline inspection technique that uses devices known in the industry as intelligent or smart pigs. These devices run inside the pipe and provide indications of metal loss, deformation, and other defects.

*in-line inspection tools*: any instrumented device or vehicle that records data and uses nondestructive test methods or other techniques to inspect the pipeline from the inside. Also known as intelligent or smart pig.

*in-service pipeline*: a pipeline that contains liquid to be transported. The liquid may or may not be flowing.

*inspection*: use of a nondestructive testing technique or method.

*integrity*: the capability of the pipeline to withstand all anticipated loads (including hoop stress due to operating pressure) within the design factor established by this section.

*integrity assessment*: process that includes inspection of pipeline facilities, evaluating the indications resulting from the inspections, examining the pipe using a variety of techniques, evaluating the results of the examinations, characterizing the evaluation by defect type and severity, and determining the resulting integrity of the pipeline through analysis.

*internal design pressure*: internal pressure used in calculations or analysis for pressure design of a piping component (see para. 401.2.2.2); it includes factors presented in para. 403.2.1.

*launcher*: pipeline device used to insert a pig into a pressurized pipeline, sometimes referred to as a pig trap.

*leak*: unintentional escape of liquid from the pipeline. The source of the leak may be holes, cracks (including propagating and nonpropagating, longitudinal, and circumferential), separation, or pull-out and loose connections.

*length*: a piece of pipe of the length delivered from the mill. Each piece is called a length, regardless of its actual dimension. This is sometimes called a joint, but "length" is preferred.

*line section or pipeline section*: continuous run of pipe between adjacent pump stations, between a pump station and a block valve, or between adjacent block valves.

*liquefied petroleum gas(es) (LPG)*: liquid petroleum composed predominantly of the following hydrocarbons, either by themselves or as mixtures: butane (normal butane or isobutane), butylene (including isomers), propane, propylene, and ethane.

*liquid alcohol*: any of a group of organic compounds containing only hydrogen, carbon, and one or more hydroxyl radicals that will remain liquid in a moving stream in a pipeline.

*liquid anhydrous ammonia*: a compound formed by the combination of the two gaseous elements nitrogen and hydrogen, in the proportion of one part of nitrogen to three parts of hydrogen, by volume, compressed to a liquid state.

*magnetic-particle inspection (MPI)*: a nondestructive test method utilizing magnetic leakage fields and suitable indicating materials to disclose surface and near-surface discontinuity indications.

*mainline pipelines*: all in-line pipeline pipes, fittings, bends, elbows, check valves, and block valves between scraper traps.

*maximum operating pressure*: a pressure established by the operating company that is the highest pressure at which a piping system can be operated with appropriate consideration for

- (a) internal design pressure
- (b) hydrostatic test pressure
- (c) design pressure of any pipeline components
- (d) safe operating pressure
- (e) deviations from normal steady-state operating conditions

*maximum steady-state operating pressure*: maximum pressure (sum of static head pressure, pressure required to overcome friction losses, and any back pressure) at

any point in a piping system when the system is operating under steady-state conditions.

*mechanical damage*: type of metal damage in a pipe or pipe coating caused by the application of an external force. Mechanical damage can include denting, coating removal, metal removal, metal movement, cold working of the underlying metal, puncturing, and residual stresses.

*metal loss*: types of anomalies in pipe in which metal has been removed from the pipe surface, usually due to corrosion or gouging.

*miter*: two or more straight sections of pipe matched and joined on a line bisecting the angle of junction so as to produce a change in direction.

*mitigation*: limitation or reduction of the probability of occurrence or expected consequence for a particular event.

*nominal pipe size (NPS)*: see ASME B36.10M, p. 1 for definition.

*nondestructive examination (NDE) or nondestructive testing (NDT)*: testing method, such as radiography, ultrasonic, magnetic testing, liquid penetrant, visual, leak testing, eddy current, and acoustic emission, or a testing technique, such as magnetic flux leakage, magnetic-particle inspection, shear-wave ultrasonic, and contact compression-wave ultrasonic.

*operator or operating company*: individual, partnership, corporation, public agency, owner, agent, or other entity currently responsible for the design, construction, inspection, testing, operation, and maintenance of the pipeline facilities.

*oxyfuel gas welding (OFW)*<sup>1</sup>: a group of welding processes that produces coalescence of workpieces by heating them with an oxyfuel gas flame. The processes are used with or without the application of pressure and with or without filler metal.

*petroleum*: crude oil, condensate, natural gasoline, natural gas liquids, liquefied petroleum gas, and liquid petroleum products.

*pig*: a device passed internally through the inside of a pipeline to clean or inspect the pipeline, or to separate batch fluids.

*pigging*: use of any independent, self-contained device, tool, or vehicle that moves through the interior of the pipeline for inspecting, dimensioning, cleaning, or drying.

*pipe*: a tube, usually cylindrical, used for conveying a fluid or transmitting fluid pressure, normally designated “pipe” in the applicable specification. It also includes any similar component designated as “tubing” used for the same purpose. Types of pipe, according to the method of manufacture, are defined below.

*double submerged arc welded pipe*: pipe having a longitudinal or helical seam butt joint produced by at least two passes, one of which is on the inside of the pipe. Coalescence is produced by heating with an electric arc or arcs between the bare metal electrode or electrodes and the work. The welding is shielded by a blanket of granular, fusible material on the work. Pressure is not used and filler metal for the inside and outside welds is obtained from the electrode or electrodes.

*electric flash welded pipe*: pipe having a longitudinal butt joint wherein coalescence is produced simultaneously over the entire area of abutting surfaces by the heat obtained from resistance to the flow of electric current between the two surfaces, and by the application of pressure after heating is substantially completed. Flashing and upsetting are accompanied by expulsion of metal from the joint.

*electric fusion welded pipe*: pipe having a longitudinal or helical seam butt joint wherein coalescence is produced in the preformed tube by manual or automatic electric arc welding. The weld may be single or double and may be made with or without the use of filler metal. Helical seam welded pipe is also made by the electric fusion welded process with either a lap joint or a lock-seam joint.

*electric induction welded pipe*: pipe produced in individual lengths or in continuous lengths from coiled skelp having a longitudinal or helical seam butt joint wherein coalescence is produced by the heat obtained from resistance of the pipe to induced electric current, and by application of pressure.

*electric resistance welded pipe*: pipe produced in individual lengths or in continuous lengths from coiled skelp, having a longitudinal or helical seam butt joint wherein coalescence is produced by the heat obtained from resistance of the pipe to the flow of electric current in a circuit of which the pipe is a part, and by the application of pressure.

*furnace butt welded pipe*:

*furnace butt welded pipe, bell welded*: pipe produced in individual lengths from cut-length skelp, having its longitudinal butt joint forge welded by the mechanical pressure developed in drawing the furnace-heated skelp through a cone-shaped die (commonly known as the “welding bell”) that serves as a combined forming and welding die.

*furnace butt welded pipe, continuous welded*: pipe produced in continuous lengths from coiled skelp and subsequently cut into individual lengths, having its longitudinal butt joint forge welded by the mechanical pressure developed in rolling the hot formed skelp through a set of round pass welding rolls.

*furnace lap welded pipe*: pipe having a longitudinal lap joint made by the forge welding process wherein coalescence is produced by heating the preformed tube to welding temperature and passing it over a mandrel located between two welding rolls that compress and weld the overlapping edges.

*seamless pipe*: pipe produced by piercing a billet followed by rolling or drawing, or both.

*pipeline*: all parts of physical facilities through which liquid moves in transportation, including pipe, valves, fittings, flanges (including bolting and gaskets), regulators, pressure vessels, pulsation dampeners, relief valves, appurtenances attached to pipe, pump units, metering facilities, pressure-regulating stations, pressure-limiting stations, pressure relief stations, and fabricated assemblies. Included within this definition are liquid transmission and gathering lines, which transport liquids from production facilities to onshore locations, and liquid storage equipment of the closed pipe type, which is fabricated or forged from pipe or fabricated from pipe and fittings.

*pipeline section*: continuous run of pipe between adjacent pump stations, between a pump station and a block valve, or between adjacent block valves.

*pipe nominal wall thickness*: the wall thickness listed in applicable pipe specifications or dimensional standards included in this Code by reference. The listed wall thickness dimension is subject to tolerances as given in the specification or standard.

*pipe supporting elements*: pipe supporting elements consist of fixtures and structural attachments as follows:

(a) *Fixtures*. Fixtures include elements that transfer the load from the pipe or structural attachment to the supporting structure or equipment. They include hanging-type fixtures, such as hanger rods, spring hangers, sway braces, counterweights, turnbuckles, struts, chains, guides, and anchors, and bearing-type fixtures, such as saddles, bases, rollers, brackets, and sliding supports.

(b) *Structural Attachments*. Structural attachments include elements that are welded, bolted, or clamped to the pipe, such as clips, lugs, rings, clamps, clevises, straps, and skirts.

*pitting*: localized corrosion of a metal surface that is confined to a small area and takes the form of cavities called *pits*.

*pressure*: unless otherwise stated, pressure is expressed in pounds per square inch (bar) above atmospheric pressure, i.e., gage pressure as abbreviated psig (bar).

*pressure test*: means by which the integrity of a piece of equipment (pipe) is assessed, in which the item is filled with a fluid, sealed, and subjected to pressure. It is used to validate integrity and detect construction defects and defective materials.

*qualification*: demonstrated and documented knowledge, skills, and abilities, along with documented training and/or experience required for personnel to properly perform the duties of a specific job or task.

*receiver*: pipeline device used for removing a pig from a pressurized pipeline, sometimes referred to as a pig trap.

*residual stress*: stress present in an object in the absence of any external loading, typically resulting from manufacturing or construction processes.

*resistivity*:

(a) resistance per unit length of a substance with uniform cross section.

(b) measure of the ability of an electrolyte (e.g., soil) to resist the flow of electric charge (e.g., cathodic protection current).

*return interval*: statistically determined time interval between successive events of design environmental conditions being equaled or exceeded.

*right-of-way (ROW)*: strip of land on which pipelines, railroads, power lines, roads, highways, and other similar facilities are constructed. Generally, a written ROW agreement secures the right to pass over property owned or occupied by others. ROW agreements generally allow the right of ingress and egress for the installation, operation, and maintenance of the facility. ROW width varies based on such factors as existing land use, construction work space, environmental restrictions, and maintenance requirements of the facility. The width is typically specified in the ROW agreement, following negotiation with the affected landowner, by legal action, or by permitting authority.

*risk*: measure of potential loss in terms of both the incident probability (likelihood) of occurrence and the magnitude of the consequences.

*safe operating pressure*: the pressure derived by calculating the remaining strength at an anomaly or defect using an acceptable method (e.g., ASME B31G or an engineering analysis) and applying an appropriate safety or design factor.

*seam weld*: longitudinal or helical weld in pipe.

*segment*: length of pipeline or part of the system that has unique characteristics in a specific geographic location.

*semiautomatic welding*<sup>1</sup>: manual welding with equipment that automatically controls one or more of the welding conditions.

*shall*: “shall” or “shall not” is used to indicate that a provision is mandatory.

*shielded metal arc welding (SMAW)*<sup>1</sup>: an arc welding process with an arc between a covered electrode and the weld pool. The process is used with shielding from the decomposition of the electrode covering, without the application of pressure, and with filler metal from the electrode.

*should*: “should” or “it is recommended” is used to indicate that a provision is not mandatory but recommended as good practice.

*smart pig*: general industry term for internal inspection devices (see *in-line inspection*).



*soil liquefaction*: a soil condition, typically caused by dynamic cyclic loading (e.g., earthquake, waves), where the effective shear strength of the soil is reduced such that the soil exhibits the properties of a liquid.

*span*: a section of pipe that is unsupported.

*specified minimum yield strength,  $S_y$* : expressed in pounds per square inch (psi) or in megapascals (MPa), minimum yield strength prescribed by the specification under which the pipe was manufactured.

*strain*: change in length of a material in response to an applied force, expressed on a unit length basis (e.g., inches per inch or millimeters per millimeter).

*stress*: resistance of a body to an applied force, expressed in units of force per unit area (psi or MPa). It may also be termed unit stress.

*stress corrosion cracking (SCC)*: form of environmental attack of the metal involving an interaction of a local corrosive environment and stresses in the metal, resulting in formation and growth of cracks.

*stress level*: level of tangential or hoop stress, usually expressed as a percentage of specified minimum yield strength.

*submerged arc welding (SAW)<sup>1</sup>*: an arc welding process that uses an arc or arcs between a bare metal electrode or electrodes and the weld pool. The arc and molten metal are shielded by a blanket of granular flux on the workpieces. The process is used without pressure and with filler metal from the electrode and sometimes from a supplementary source (welding rod, flux, or metal granules).

*survey*:

(a) measurements, inspections, or observations intended to discover and identify events or conditions that indicate a departure from normal operation or undamaged condition of the pipeline.

(b) measurement of the physical location of installed pipe and/or facilities in relation to known landmarks or geographic features.

*system or pipeline system*: either the operator's entire pipeline infrastructure or large portions of the infrastructure that have definable starting and stopping points.

*tack weld<sup>1</sup>*: a weld made to hold parts of a weldment in proper alignment until the final welds are made.

*temperatures*: expressed in degrees Fahrenheit (°F) unless otherwise stated.

*tensile stress*: applied pulling force divided by the original cross-sectional area.

*tie-in*: a connection where a gap was left to divide a pipeline into test sections, or to install a pretested replacement section, or in the continuous line construction at a location such as a river or a highway crossing.

*tie-in weld*: a tie-in connection using a weld, typically a girth weld.

*tool*: generic term signifying any type of instrumented device or pig.

*training*: organized program developed to impart the knowledge and skills necessary for qualification.

*weight coating*: any coating applied to the pipeline for the purpose of increasing the pipeline specific gravity.

*weld<sup>1</sup>*: a localized coalescence of metals or nonmetals produced either by heating the materials to the welding temperature, with or without the application of pressure, or by the application of pressure alone and with or without the use of filler material.

*welder<sup>1</sup>*: one who performs manual or semiautomatic welding.

*welding operator<sup>1</sup>*: one who operates adaptive control, automatic, mechanized, or robotic welding equipment.

*welding procedures<sup>1</sup>*: the detailed methods and practices involved in the production of a weldment.

*wrinkle bend*: pipe bend produced by a field machine or controlled process that may result in prominent contour discontinuities on the inner radius. The wrinkle is deliberately introduced as a means of shortening the inside meridian of the bend.

## Chapter II Design

### 401 LOADS

#### 401.1 Load Classifications

**401.1.1 Classification of Loads.** The design of a pipeline shall be based on consideration of the loads identified in this section to the extent that they are significant to the proposed system and applicable to the proposed installation and operation. Loads that may cause or contribute to pipeline failure or loss of serviceability of the pipeline system shall be identified and accounted for in the design. For strength design, loads shall be classified as one of the following:

- (a) sustained
- (b) occasional
- (c) construction
- (d) transient

**401.1.2 Sustained Loads.** Sustained loads are those arising from the intended use of the pipeline system and loads from other sources. The weight of the pipeline, including components, fluids, and slurries, and loads due to pressure are examples of sustained loads. Soil cover, external hydrostatic pressure, and vibration due to equipment are examples of sustained loads from other sources. Reaction forces at supports from sustained loads and loads due to sustained displacement or rotations of supports are also sustained loads.

**401.1.3 Occasional Loads.** Examples of occasional loads are those resulting from wind, snow, ice, seismic, road and rail traffic, temperature change, currents, and waves except where they need to be considered as sustained loads (loads caused by temperature change may also be considered sustained in some instances). Loads resulting from prestressing, residual forces from installation, subsidence, differential settlement, frost heave, and thaw settlement are included in occasional loads.

**401.1.4 Construction Loads.** Loads necessary for the installation and pressure testing of the pipeline system are construction loads. Examples of construction loads include handling, storage, installation, and hydrotesting.

**401.1.5 Transient Loads.** Loads that may occur during operation of the pipeline, such as fire, impact, falling objects, and transient conditions (during landslides, third-party damage, equipment collisions, and accidental

overpressure), including surge, are examples of transient loads.

#### 401.2 Application of Loads

**401.2.1 Restrained Versus Unrestrained.** The restraint condition is a factor in the structural behavior of the pipeline and, consequently, affects stresses and applicable stress limits. The degree of restraint may vary with pipeline construction activities, support conditions, soil properties, terrain, and time. For purposes of design, this Code recognizes two restraint conditions, restrained and unrestrained. Guidance in categorizing the restraint condition is given below. Examples given are neither comprehensive nor definitive.

(a) "Unrestrained" means that the pipe is free to displace laterally and to strain axially. Unrestrained pipelines may include the following:

- (1) aboveground pipe that is configured to accommodate thermal expansion or support movement
- (2) field bends and adjacent pipe buried in soft or unconsolidated soil
- (3) an unbackfilled section of buried pipeline that is free to displace laterally or that contains a bend
- (4) unanchored sections of pipe

(b) Restrained pipelines may include the following:

- (1) sections of buried pipe
- (2) sections of aboveground pipe attached to closely spaced rigid supports, anchored at each end and at changes in direction
- (3) field bends and adjacent pipe buried in stiff or consolidated soil

Portions of buried pipeline may be only partially restrained. Pipe-to-soil interactions should be evaluated to ensure that the soil provides adequate restraint to limit the movement of the pipeline as may be required to prevent unacceptable levels of stress and/or strain in the pipe and to prevent failure of the soil support, particularly at overbends and side bends. Guidance on the movement at pipe bends, soil interaction including soil-bearing capacity, and soil springs used to represent soil forces on pipe may be found in the ASCE publication American Lifelines Alliance "Guidelines for the Design of Buried Pipelines," July 2001 (with Addenda through 2005) and ASME B31.1, Nonmandatory Appendix VII.

## 401.2.2 Sustained Loads

**401.2.2.1 General.** In the case of constant loads, the expected value of the load shall be used. In the case of variable loads, the specified highest or lowest value shall be used, whichever is more critical. In the case of loads caused by deformation, the expected extreme value shall be used.

**401.2.2.2 Internal Design Pressure.** The pipe and components at any point in the pipeline shall be designed for an internal design pressure that shall not be less than the maximum steady-state operating pressure at that point, nor less than the static head pressure at that point with the pipeline in a static condition. The maximum steady-state operating pressure shall be the sum of the static head pressure, pressure required to overcome friction losses, and applied back pressure. Credit may be taken for hydrostatic external pressure by modifying the internal design pressure for use in calculations involving the pressure design of pipe and components. Pressure rise above maximum steady-state operating pressure due to surges and other variations from normal operations is allowed in accordance with [para. 403.3.4](#).

**401.2.2.3 External Hydrostatic Pressure.** The pipeline shall be designed to withstand the maximum expected differential between external and internal pressures.

**401.2.2.4 Weight Effects.** Weight effects combined with loads and forces from other causes shall be considered in the design of pipelines. The effect of the combined weight of pipe, coating, and other attachments (in air and submerged) on installation stresses and strains shall be considered. Variability due to weight coating manufacturing tolerances and water absorption shall also be considered.

**401.2.2.5 Residual Loads.** The pipeline system shall normally be installed in a manner so as to minimize residual loads. An exception is when a designer purposefully plans for residual loads.

**401.2.2.6 Subsidence.** Loads resulting from subsidence shall be considered in design when pipelines or pipeline segments are located in areas where subsidence is known to occur.

## 401.2.3 Occasional Loads

**401.2.3.1 Earthquakes.** The following effects shall be considered when designing for earthquakes:

- (a) direct effects due to ground vibrations
- (b) induced effects (liquefaction, landslides)
- (c) effects due to crossing of active faults at the surface

**401.2.3.2 Wind Loads.** Wind loads shall be considered in the design of above-grade pipelines. Refer to ASCE 7 for the application of wind loads.

**401.2.3.3 Ice Loads.** The following effects shall be considered when designing for ice loads:

- (a) ice frozen on pipelines and supporting structures
- (b) drifting ice (river ice breakup or inshore waters)
- (c) impact forces due to thaw of the ice
- (d) forces due to expansion of the ice

**401.2.3.4 Road and Rail Traffic.** Earth load and cyclic rail and truck loads shall be considered. Maximum traffic axle loads shall be established in consultation with the appropriate traffic authorities and others operating in the vicinity of the pipeline.

**401.2.3.5 Vibration.** Loads resulting from vibration (including Karmon vortex effect) and resonance shall be considered.

**401.2.3.6 Waves and Currents.** Loads resulting from waves and currents shall be considered in the design of pipelines across waterways.

**401.2.3.7 Temperature Effects.** The design temperature is the metal temperature expected in normal operation. It is not necessary to vary the design stress for metal temperatures between  $-20^{\circ}\text{F}$  ( $-30^{\circ}\text{C}$ ) and  $250^{\circ}\text{F}$  ( $120^{\circ}\text{C}$ ). However, some of the materials conforming to specifications approved for use under this Code may not have properties suitable for the lower portion of the temperature band covered by this Code. Attention shall be given to the low-temperature properties of the materials used for facilities to be exposed to unusually low ground temperatures, low atmospheric temperatures, or transient operating conditions.

The design temperature should be established considering temperature variations resulting from pressure changes and extreme ambient temperatures.

Consideration should be given to possible conditions that may cause low temperatures on pipelines transporting liquids that become gases at or near atmospheric conditions. See ASME B31T for more information about evaluating the suitability of piping materials that may be subject to brittle failure due to low-temperature service conditions.

When piping is exposed to the sun, consideration should be given to the metal temperature and fluid expansion resulting from solar heat gain.

## 401.2.4 Construction Loads

**401.2.4.1 Installation Loads.** Loads induced during transportation, handling, storage, and lowering-in shall be considered. Increases in external pressure during pressure grouting or decreases in internal pressure during vacuum drying shall be considered as installation loads.

**401.2.4.2 Hydrostatic Testing.** Loads that occur during hydrostatic testing shall be considered. These loads include weight of contents, thermal, and pressured end effect.

### 401.3 Combining of Loads

When calculating equivalent stresses or strains, the most critical combination of sustained, occasional, construction, and transient loads that can be expected to occur shall be considered.

If the operating philosophy is to maintain full operation during extreme environmental conditions, the system shall be designed for concurrent action of the expected sustained and occasional loads.

If the operating philosophy is such that operations will be reduced or discontinued under extreme environmental conditions, the following load combinations shall be considered:

(a) the design operating loads plus the environmental loads at the permissible level

(b) the reduced operating loads plus the maximum environmental loads

Unless they can be reasonably expected to occur together, it is not necessary to consider a combination of transient loads in combination with occasional loads.

Effects of sustained loads caused by deformations shall be taken into account only to the extent that the capacity to withstand other loads is affected.

When combining environmental loads with construction loads, the environmental loading should be selected to reflect the most severe loading likely to be encountered during the construction phase.

When considering loads during tests, it is not necessary to consider occasional or transient loads as occurring concurrently with the sustained and construction loads existing at the time of the test.

## 402 CALCULATION OF STRESSES

### (19) 402.1 General

Circumferential, longitudinal, shear, and equivalent stresses shall be considered, taking into account stresses from all relevant sustained, occasional, construction, and transient loads, including vibration, resonance, and subsidence. The effects of all parts of the pipeline and all restraints, supports, guides, and sources of friction shall be considered. When flexibility calculations are performed, linear and angular movements of equipment to which the pipeline has been attached shall also be considered.

Calculations shall take into account stress intensification factors found to exist in components other than plain straight pipe. Credit may be taken for extra flexibility of such components. In the absence of more directly applicable data, the flexibility factors and stress intensification factors shown in [Table 402.1-1](#) or ASME B31J may be used.

Calculations of pipe stresses in loops, bends, and offsets shall be based on the total range from minimum to maximum temperature normally expected, regardless of whether piping is cold sprung or not. In addition to

expansion of the line itself, the linear and angular movements of the equipment to which it is attached shall be considered.

Calculations of thermal forces and moments on anchors and equipment such as pumps, meters, and heat exchangers shall be based on the difference between installation temperature and minimum or maximum anticipated operating temperature, whichever results in a higher stress.

Nominal dimensions of pipe and fittings shall be used in flexibility calculations.

### 402.2 Properties

**402.2.1 Coefficient of Thermal Expansion.** The linear coefficient of thermal expansion for carbon and low alloy high tensile steel may be taken as  $6.5 \times 10^{-6}$  in./in./°F for temperatures up to 250°F ( $11.7 \times 10^{-6}$  mm/mm/°C for temperatures up to 120°C).

**402.2.2 Moduli of Elasticity.** Flexibility calculations shall be based on the modulus of elasticity at ambient temperature.

**402.2.3 Poisson's Ratio,  $\nu$ .** Poisson's ratio shall be taken as 0.3 for steel.

### 402.3 Stress From Internal Pressure

For both restrained and unrestrained pipelines, the circumferential (hoop) stress due to internal pressure is calculated as

(U.S. Customary Units)

$$S_H = \frac{P_i D}{2t}$$

(SI Units)

$$S_H = \frac{P_i D}{20t}$$

where

$D$  = outside diameter of pipe, in. (mm)

$P_i$  = internal design gage pressure, psi (bar)

$S_H$  = circumferential (hoop) stress due to internal pressure, psi (MPa)

$t$  = wall thickness of pipe, in. (mm)

The above equation may not be applicable for pipe  $D/t$  less than 20.

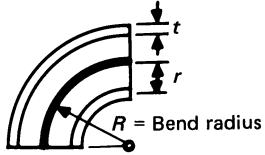
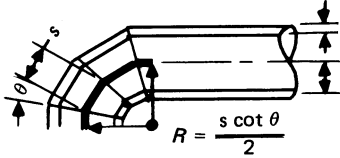
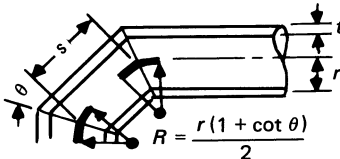
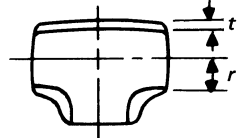
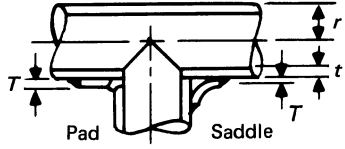
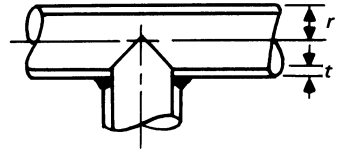
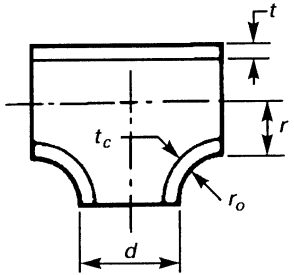
### 402.4 Stress From External Pressure

For both restrained and unrestrained pipelines, the circumferential stress from external pressure,  $P_e$ , is calculated as for internal pressure, substituting  $P_e$  for  $P_i$ . For external pressure in the equation, compressive stress is negative.

Offshore pipe systems require additional considerations. Refer to [Chapter IX](#).



**Table 402.1-1 Flexibility Factor, *k*, and Stress Intensification Factor, *i***

Description	Flexibility Factor, <i>k</i>	Stress Intensification Factor		Flexibility Characteristic, <i>h</i>	Sketch
		<i>i<sub>i</sub></i> [Note (1)]	<i>i<sub>o</sub></i> [Note (2)]		
Welding elbow, or pipe bend [Notes (3)–(7)]	$\frac{1.65}{h}$	$\frac{0.9}{h^{2/3}}$	$\frac{0.75}{h^{2/3}}$	$\frac{tR}{r^2}$	
Closely spaced miter bend [Notes (3)–(5), and (7)], <i>s</i> < <i>r</i> (1 + tan $\theta$ )	$\frac{1.52}{h^{5/6}}$	$\frac{0.9}{h^{2/3}}$	$\frac{0.75}{h^{2/3}}$	$\frac{\cot \theta}{2} \frac{ts}{r^2}$	
Widely spaced miter bend [Notes (3), (4), (7), and (8)], <i>s</i> < <i>r</i> (1 + tan $\theta$ )	$\frac{1.52}{h^{5/6}}$	$\frac{0.9}{h^{2/3}}$	$\frac{0.75}{h^{2/3}}$	$\frac{1 + \cot \theta}{2} \frac{t}{r}$	
Welding tee [Notes (3) and (4)] per ASME B16.9	1	$0.75i_o + 0.25$	$\frac{0.9}{h^{2/3}}$	$4.4 \frac{t}{r}$	
Reinforced tee [Notes (3), (4), and (9)] with pad or saddle	1	$0.75i_o + 0.25$	$\frac{0.9}{h^{2/3}}$	$\frac{(t + 1/2 T)^{5/2}}{t^{3/2} r}$	
Unreinforced fabricated tee [Notes (3) and (4)]	1	$0.75i_o + 0.25$	$\frac{0.9}{h^{2/3}}$	$\frac{t}{r}$	
Extruded welding tee [Notes (3), (4), and (10)], <i>r<sub>o</sub></i> ≥ 0.05 <i>d</i> <i>t<sub>c</sub></i> < 1.5 <i>t</i>	1	$0.75i_o + 0.25$	$\frac{0.9}{h^{2/3}}$	$\left(1 + \frac{r_o}{r}\right) \frac{t}{r}$	
Butt welded joint, reducer, or welding neck flange	1		1.0	...	...
Double welded slip-on flange	1		1.2	...	...

**Table 402.1-1 Flexibility Factor, *k*, and Stress Intensification Factor, *i* (Cont'd)**

Description	Flexibility Factor, <i>k</i>	Stress Intensification Factor		Flexibility Characteristic, <i>h</i>	Sketch
		<i>i<sub>i</sub></i> [Note (1)]	<i>i<sub>o</sub></i> [Note (2)]		
Fillet welded joint (single welded), or single welded slip-on flange	1		1.3	...	...
Lapped flange (with ASME B16.9 lap-joint stub)	1		1.6	...	...
Threaded pipe joint, or threaded flange	1		2.3	...	...
Corrugated straight pipe, or corrugated or creased bend [Note (11)]	5		2.5	...	...

NOTES:

- (1) In-plane.
- (2) Out-of-plane.
- (3) For fittings and miter bends, the flexibility factors, *k*, and stress intensification factors, *i*, in the Table apply to bending in any plane and shall not be less than unity; factors for torsion equal unity. Both factors apply over the effective arc length (shown by heavy centerlines in the sketches) for curved and miter elbows, and to the intersection point for tees.
- (4) The values of *k* and *i* can be read directly from Chart A by entering with the characteristic, *h*, computed from the equations given, where  
*d* = outside diameter of branch  
*R* = bend radius of welding elbow or pipe bend, in. (mm)  
*r* = mean radius of matching pipe, in. (mm)  
*r<sub>o</sub>* = see Note (10)  
*s* = miter spacing at centerline  
*T* = pad or saddle thickness, in. (mm)  
*t* = nominal wall thickness of: part itself, for elbows and curved or mited bends; matching pipe, for welding tees; run or header, for fabricated tees (provided that if thickness is greater than that of matching pipe, increased thickness must be maintained for at least one run O.D. to each side of the branch O.D.)  
*t<sub>c</sub>* = the crotch thickness of tees  
 $\theta$  = one-half angle between adjacent miter axes, deg
- (5) Where flanges are attached to one or both ends, the values of *k* and *i* in this Table shall be corrected by the factors *C<sub>1</sub>* given below, which can be read directly from Chart B, entering with the computed *h*: one end flanged,  $h^{1/6} \geq 1$ ; both ends flanged,  $h^{1/3} \geq 1$ .
- (6) The engineer is cautioned that cast butt welding elbows may have considerably heavier walls than that of the pipe with which they are used. Large errors may be introduced unless the effect of these greater thicknesses is considered.
- (7) In large diameter thin wall elbows and bends, pressure can significantly affect the magnitude of flexibility and stress intensification factors. To correct values obtained from this Table for the pressure effect, divide

$$\text{Flexibility factor, } k, \text{ by } 1 + 6 \frac{P}{E_c} \left(\frac{r}{t}\right)^{7/3} \left(\frac{R}{r}\right)^{1/3}$$

$$\text{Stress intensification factor, } i, \text{ by } 1 + 3.25 \frac{P}{E_c} \left(\frac{r}{t}\right)^{5/2} \left(\frac{R}{r}\right)^{2/3}$$

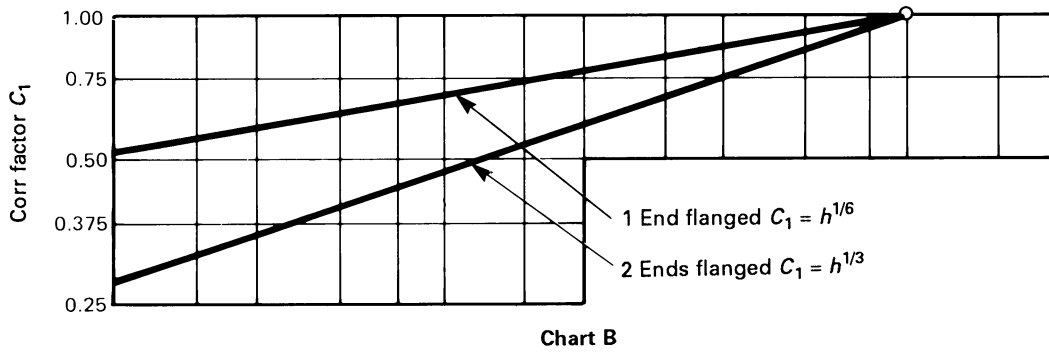
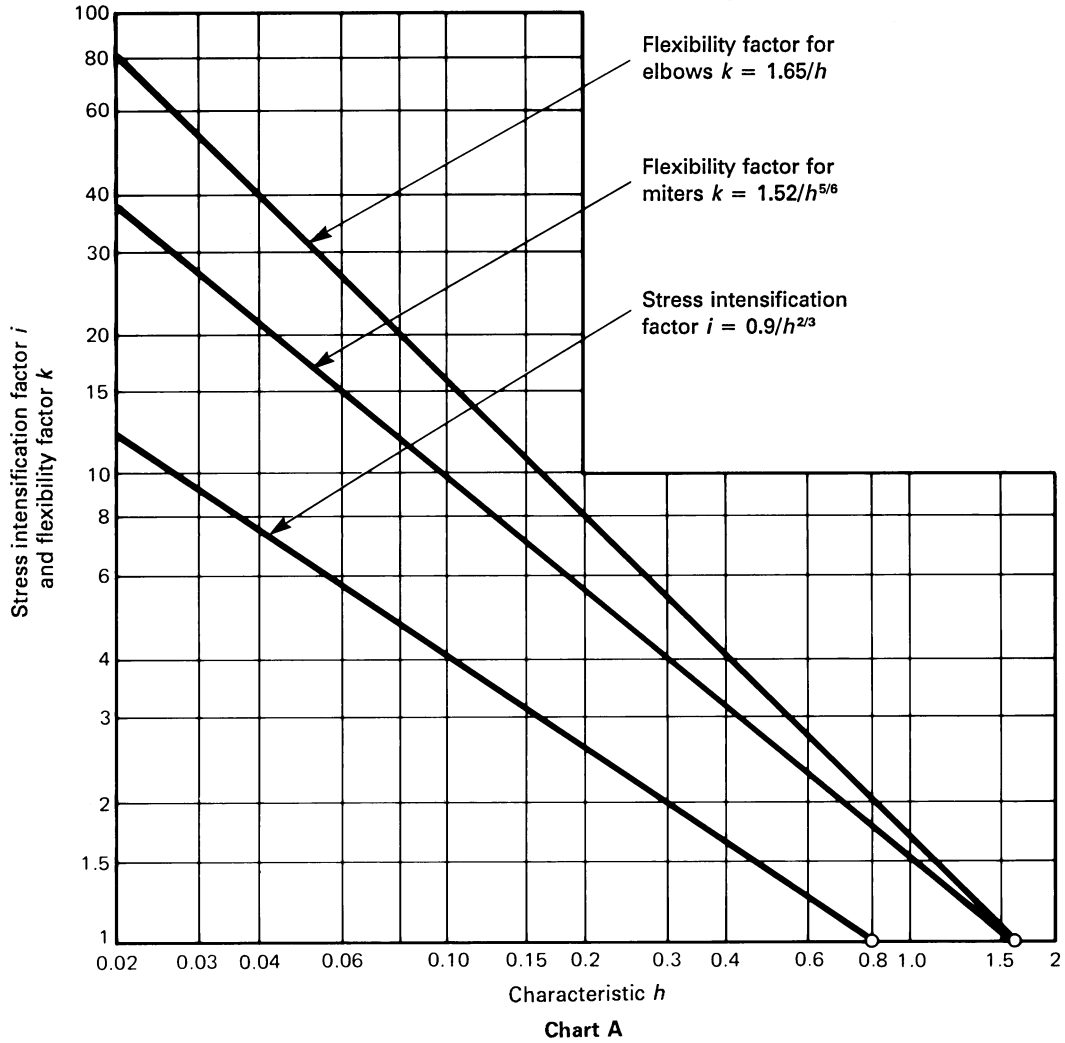
where

*E<sub>c</sub>* = cold modulus of elasticity  
*P* = gage pressure

- (8) Also includes single miter joint.
- (9) When  $T > 1\frac{1}{2}t$ , use  $h = 4.05 t/r$ .
- (10) Radius of curvature of external contoured portion of outlet measured in the plane containing the axes of the run and branch. This is subject to the following limitations:
  - (a) minimum radius, *r<sub>o</sub>*: the lesser of 0.05*d* or 1.5 in. (38 mm)
  - (b) maximum radius, *r<sub>o</sub>*, shall not exceed
    - (1) for branches DN 200 (NPS 8) and larger, 0.10*d* + 0.50 in. (13 mm)
    - (2) for branches less than DN 200 (NPS 8), 1.25 in. (32 mm)
  - (c) When the external contour contains more than one radius, the radius on any arc sector of approximately 45 deg shall meet the requirements of (a) and (b) above.
  - (d) Machining shall not be employed in order to meet the above requirements.
- (11) Factors shown apply to bending; flexibility factor for torsion equals 0.9.

Table 402.1-1 Flexibility Factor,  $k$ , and Stress Intensification Factor,  $i$  (Cont'd)

NOTES: (Cont'd)



## 402.5 Stress From Thermal Expansion

**402.5.1 Restrained Pipe.** Thermal expansion stress in restrained pipe is calculated as

$$S_E = E\alpha(T_1 - T_2)$$

where

- $E$  = moduli of elasticity
- $S_E$  = thermal expansion stress, psi (MPa)
- $T_1$  = temperature of the pipe at installation or completion of final tie-in, °F (°C)
- $T_2$  = operating temperature, °F (°C)
- $\alpha$  = coefficient of thermal expansion, in./in./°F (mm/mm/°C)

In the above equation, compressive stress is a negative value.

- (19) **402.5.2 Unrestrained Pipe.** Calculations shall take into account flexibility and stress intensification factors of piping components.

The stress range resulting from thermal expansion in pipe, fittings, and components in unrestrained pipeline is calculated as follows, using the modulus of elasticity at the installed temperature:

$$S_E = \sqrt{S_b^2 + 4S_t^2}$$

where

- $S_b$  = resultant bending stress, psi (MPa)
- $S_t$  = torsional stress, psi (MPa)

Thermal stress shall be calculated for the range of minimum and maximum operating temperatures.

The resultant bending stress,  $S_b$ , is calculated as follows:

$$S_b = \sqrt{(i_i M_i)^2 + (i_o M_o)^2} / Z$$

where

- $i_i$  = in-plane stress intensification factor in accordance with para. 402.1. Note that  $i_i$  is 1 for pipe.
- $i_o$  = out-of-plane stress intensification factor in accordance with para. 402.1. Note that  $i_o$  is 1 for pipe.
- $M_i$  = in-plane bending moment, in.-lb (N·m)
- $M_o$  = out-of-plane bending moment, in.-lb (N·m)
- $Z$  = section modulus of the pipe or of the fitting outlet, as applicable, in.<sup>3</sup> (cm<sup>3</sup>)

Resultant torsional stress,  $S_t$ , is calculated as

$$S_t = \frac{M_t}{2Z}$$

where

- $M_t$  = torsional moment, in.-lb (N·m)

## 402.6 Longitudinal Stress

**402.6.1 Restrained Pipe.** Longitudinal stress in (19) restrained pipe is calculated as

$$S_L = S_E + \nu S_H + \frac{M}{Z} + F_a/A$$

where

- $A$  = metal area of nominal pipe cross section, in.<sup>2</sup> (mm<sup>2</sup>)
- $F_a$  = axial force, such as weight on a riser, lb (N)
- $M$  = bending moment, in.-lb (N·m)
- $S_E$  = thermal expansion stress, psi (MPa)
- $S_H$  = circumferential (hoop) stress due to internal pressure, psi (MPa)
- $Z$  = section modulus of the pipe, in.<sup>3</sup> (cm<sup>3</sup>)
- $\nu$  = Poisson's ratio

Examples of force,  $F_a$ , are forces due to the differential pressure on a buried valve and frictional forces due to pipe movement through the soil.  $F_a$  can be positive or negative, depending on the direction of the force.

$S_H$  can be either a positive or negative value.

Both positive and negative values of  $M/Z$  shall be considered in the analysis.

Residual stresses from construction are often present for spanning, elastic bends, and differential settlement. Designers should determine if such stresses need to be evaluated.

**402.6.2 Unrestrained Pipe.** The longitudinal stress (19) from pressure and external loadings in unrestrained pipe is calculated as

(U.S. Customary Units)

$$S_L = \frac{P_i D}{4t} + \frac{iM}{Z} + \frac{F_a}{A}$$

(SI Units)

$$S_L = \frac{P_i D}{40t} + \frac{iM}{Z} + \frac{F_a}{A}$$

where

- $A$  = metal area of nominal pipe cross section, in.<sup>2</sup> (mm<sup>2</sup>)
- $D$  = outside diameter of pipe, in. (mm)
- $F_a$  = axial force, such as weight on a riser, lb (N)
- $i$  = component stress intensification in plane of loading (see Table 402.1-1), limited by  $0.75i \geq 1$ . For straight pipe,  $i = 1.0$ .
- $M$  = bending moment across the nominal pipe cross section due to weight or seismic inertia loading, in.-lb (N·m)
- $P_i$  = internal design gage pressure, psi (bar)
- $t$  = wall thickness of pipe, in. (mm)
- $Z$  = section modulus of the pipe or of the fitting outlet, as applicable, in.<sup>3</sup> (cm<sup>3</sup>)

Longitudinal stress from pressure in an unrestrained line shall include consideration of bending stress or axial stress that may be caused by elongation of the pipe due to internal pressure and result in stress at bends and at connections and produce additional loads on equipment and on supports.

#### 402.7 Combining of Stresses

In restrained pipe, the longitudinal and circumferential stresses are combined in accordance with the maximum shear stress theory as follows:

$$S_{eq} = 2\sqrt{[(S_L - S_H)/2]^2 + S_t^2}$$

where

$S_{eq}$  = equivalent combined stress  
 $S_t$  = torsional stress, psi (MPa)

When  $S_t$  can be disregarded, the combined stress calculation can be reduced to the following:

$$|S_L - S_H|$$

such that when  $S_L < 0$ ,  $|S_L| \leq (S_x - S_H)$ , and when  $S_L > 0$ ,  $S_L \leq (S_x + S_H)$

where

$S_x$  = axial stress, psi (MPa)

Alternatively, the stresses may be combined in accordance with the maximum distortion energy theory as follows:

$$S_{eq} = \sqrt{S_H^2 - S_H S_L + S_L^2 + 3S_t^2}$$

#### 402.8 Stresses From Road and Rail Traffic Loads

The total effective stress due to internal design pressure, temperature change, and external loads (including sustained, occasional, and transient loads) in pipe installed under railroads or highways without use of casings shall be calculated in accordance with API RP 1102 or other calculation methods. Cyclic stress components shall be checked for fatigue.

Where casings are used, the same methodology may be used for the design of the casing.

### 403 CRITERIA FOR PIPELINES

#### 403.1 General

Design and installation analyses shall be based on accepted engineering methods, material strengths, and applicable design conditions.

The design requirements of this Code are adequate for public safety under conditions usually encountered in piping systems within the scope of this Code, including lines within villages, towns, cities, and industrial areas. However, the design shall provide reasonable protection

to prevent damage to the pipeline from unusual external conditions that may be encountered in river crossings, offshore and inland coastal water areas, bridges, areas of heavy traffic, long self-supported spans, unstable ground, vibration, weight of special attachments, or forces resulting from abnormal thermal conditions. Some of the protective measures that the design may provide are encasing with steel pipe of larger diameter, adding concrete protective coating, adding a concrete cap, increasing the wall thickness, lowering the line to a greater depth, or indicating the presence of the line with additional markers.

In no case where the Code refers to the specified minimum value of a physical property shall a higher value of the property be used in establishing the allowable stress value.

Pipelines within the scope of this Code may be subject to conditions during construction and operation where the external pressure exceeds the internal pressure. The pipe wall selected shall provide adequate strength to prevent collapse, taking into consideration mechanical properties, variations in wall thickness permitted by material specifications, out-of-roundness, bending stresses, and external loads.

The forces and moments transmitted to connected equipment, such as valves, strainers, tanks, pressure vessels, and pumps, shall be kept within stress limits specified herein and in other applicable codes.

External or internal coatings or linings of cement, plastics, or other materials may be used on steel pipe conforming to the requirements of this Code. These coatings or linings shall not be considered to add strength unless it can be demonstrated that they do so.

All in-line pipe and pipeline components shall be designed to allow passage of instrumented internal inspection devices.

#### 403.2 Criteria for Pipe Wall Thickness and Allowances

**403.2.1 Criteria.** The nominal wall thickness of straight sections of steel pipe shall be equal to or greater than  $t_n$  determined in accordance with the following equation:

$$t_n \geq t + A$$

where

$A$  = sum of allowances for threading, grooving, corrosion, and erosion as required in [paras. 403.2.2 through 403.2.4](#), and increase in wall thickness if used as protective measure in [para. 403.1](#)

$t_n$  = nominal wall thickness satisfying requirements for pressure and allowances

$t$  = pressure design wall thickness as calculated in inches (millimeters) in accordance with the following equations:

(U.S. Customary Units)

$$t = \frac{P_i D}{2S}$$

(SI Units)

$$t = \frac{P_i D}{20S}$$

where

$D$  = outside diameter of pipe, in. (mm)

$P_i$  = internal design gage pressure, psi (bar)

$S$  = applicable allowable stress value, psi (MPa), as determined by the following equation:

$$S = F \times E \times S_y$$

$E$  = weld joint factor as specified in [Table 403.2.1-1](#).

$F$  = design factor. The value of  $F$  used in this Code shall not be greater than 0.72. Where indicated by service or location, users of this Code may elect to use a design factor,  $F$ , less than 0.72. In setting design factor, due consideration has been given to and allowance has been made for the under-thickness tolerance and maximum allowable depth of imperfections provided for in the specifications approved by the Code.

$S_y$  = specified minimum yield strength of the pipe, psi (MPa).

**403.2.2 Wall Thickness and Defect Tolerances.** Wall thickness tolerances and defect tolerances for pipe shall be as specified in applicable pipe specifications or dimensional standards included in this Code by reference in [Mandatory Appendix I](#). Design factors in this Code were established with due consideration for underthickness tolerance and maximum allowable depth of imperfections allowed by the referenced standards; no additional allowance is necessary.

**403.2.3 Corrosion.** A wall thickness allowance for corrosion is not required if pipe and components are protected against corrosion in accordance with the requirements and procedures prescribed in [Chapter VIII](#).

**403.2.4 Threading and Grooving.** An allowance for thread or groove depth in inches (millimeters) shall be included in  $A$  of the equation in [para. 403.2.1](#) when threaded or grooved pipe is allowed by this Code (see [para. 404.8.3](#)).

Least nominal wall thickness for threaded pipe shall be standard wall (see ASME B36.10M).

**403.2.5 Use of High  $D/t$  Ratio.** The designer is cautioned that susceptibility to flattening, ovality, buckling, and denting increases with  $D/t$  ratio, decreased wall

**Table 403.2.1-1 Weld Joint Factors Applicable to Common Pipe Specifications**

Specification	Grade	Weld Joint Factor, $E$
<b>Seamless</b>		
API 5L	A25 through X80Q/M	1.00
ASTM A53	All	1.00
ASTM A106	All	1.00
ASTM A333	6	1.00
ASTM A524	All	1.00
<b>Furnace Butt Welded, Continuous Welded</b>		
ASTM A53	Type F, Grade A	0.60
API 5L	A25	0.60
<b>Electric Resistance Welded and Electric Flash Welded</b>		
API 5L	A25 through X80Q/M	1.00
ASTM A53	All	1.00
ASTM A135	All	1.00
ASTM A333	6	1.00
<b>Electric Fusion Welded</b>		
ASTM A134	All	0.80
ASTM A139	All	0.80
ASTM A671	All	1.00 <a href="#">[Note (1)]</a>
ASTM A671	All	0.70 <a href="#">[Note (2)]</a>
ASTM A672	All	1.00 <a href="#">[Note (1)]</a>
ASTM A672	All	0.80 <a href="#">[Note (2)]</a>
<b>Submerged Arc Welded</b>		
API 5L	A25 through X120M <a href="#">[Note (3)]</a>	1.00
ASTM A381	Y35 through Y65	1.00

GENERAL NOTES:

- For some Code computations, particularly with regard to branch connections [see [para. 404.3.5\(c\)](#)] and expansion, flexibility, structural attachments, supports, and restraints (see [para. 404.9](#)), the weld joint factor,  $E$ , need not be considered.
- Definitions for the various types of pipe are given in [para. 400.2](#).

NOTES:

- Factor applies for Class X2 pipe only, when the radiographic examination has been performed after postweld heat treatment (PWHT).
- Factor applies for Class X3 pipe (no radiographic examination) or for Class X2 pipe when the radiographic examination is performed prior to PWHT.
- For offshore applications, API 5L Annex J applies, which specifies a maximum strength grade allowed up to X80MO.

**Table 403.3.1-1 Allowable Values for Pipeline System Stresses**

Location	Internal and External Pressure Stress, $S_H$	Allowable Expansion Stress, $S_E$	Additive Longitudinal Stress, $S_L$	Sum of Longitudinal Stresses From Sustained and Occasional Loads	Equivalent Combined Stress, $S_{eq}$	Effective Stress for Casing or Uncased Pipe at Road or Railroad Crossings
Restrained pipeline	$0.72(E)S_y$	$0.90S_y$	$0.90S_y$ [Note (1)]	$0.90S_y$	$0.90S_y$	$0.90S_y$ [Note (2)]
Unrestrained pipeline	$0.72(E)S_y$	$S_A$ [Note (3)]	$0.75S_y$ [Note (1)]	$0.80S_y$	n/a	$0.90S_y$ [Note (2)]
Riser and platform piping on inland navigable waters	$0.60(E)S_y$	$0.80S_y$	$0.80S_y$	$0.90S_y$	n/a	n/a

## GENERAL NOTES:

- $S_y$  = specified minimum yield strength of pipe material, psi (MPa)
- $E$  = weld joint factor (see Table 403.2.1-1)
- In the setting of design factors, due consideration has been given to and allowance has been made for the underthickness tolerance and maximum allowable depth of imperfections provided for in the specifications approved by the Code.
- $S_L$  in the table above is the maximum allowable value for unrestrained piping calculated in accordance with para. 402.6.2. The maximum value of  $S_L$  for restrained pipe is calculated in accordance with para. 402.6.1.
- See para. 403.10 for allowable stresses of used pipe.

## NOTES:

- Beam-bending stresses shall be included in the longitudinal stress for those portions of the restrained or unrestrained line that are supported aboveground.
- Effective stress is the sum of the stress caused by temperature change and from circumferential, longitudinal, and radial stresses from internal design pressure and external loads in pipe installed under railroads or highways.
- See para. 403.3.2.

thickness, decreased yield strength, and combinations thereof. Pipe having a  $D/t$  ratio greater than 100 may require additional protective measures during construction. See para. 403.2.2 and the General Note under Table A402.3.2-1 for wall thickness allowances included in the design factors.

### 403.3 Criteria to Prevent Yield Failure

**403.3.1 Strength Criteria.** The maximum longitudinal stress due to axial and bending loads during installation and operation shall be limited to a value that prevents pipe buckling or otherwise impairs the serviceability of the installed pipeline. Other stresses resulting from pipeline installation activities such as spans shall be limited to the same criteria. Instead of a stress criterion, an allowable installation strain limit may be used.

Stress values for steel pipe during operation shall not exceed the allowable values in Table 403.3.1-1 as calculated by the equations in this Chapter.

Slurry pipe systems require additional considerations. Refer to Chapter XI.

**403.3.2 Criteria for Allowable Stress Due to Periodic or Cyclic Loading.** For unrestrained pipelines, the allowable expansion stress,  $S_A$ , is as follows:

$$S_A \leq f[1.25(S_c + S_h) - S_L]$$

where

$f$  = fatigue factor calculated as  $f = 6.0N^{-0.2}$ , but cannot exceed 1.2

$N$  = equivalent number of full displacement cycles during the expected service life of the pipeline system

$S_c = \frac{2}{3}S_y$  at the lower of the installed or minimum operating temperature

$S_h = \frac{2}{3}S_y$  at the higher of the installed or maximum operating temperature

**403.3.3 Strain Criteria for Pipelines.** When a pipeline may experience a noncyclic displacement of its support (such as fault movement along the pipeline route or differential support settlement or subsidence along the pipeline), the longitudinal and combined stress limits may be replaced with an allowable strain limit, so long as the consequences of yielding do not impair the serviceability of the installed pipeline. The permissible maximum longitudinal strain depends on the ductility of the material, any previously experienced plastic strain, and the buckling behavior of the pipe. Where plastic strains are anticipated, the pipe eccentricity, pipe out-of-roundness, and the ability of the weld to undergo such strains without detrimental effect shall be considered. Maximum strain shall be limited to 2%.

**403.3.4 Criteria for Transient Overpressure.** Transient overpressure includes pressure rise due to surge. Surge pressures in a liquid pipeline are produced by a change in the velocity of the moving fluid that results from shutting down a pump station or pumping unit, closing a valve, or blockage of the moving fluid.



Surge calculations should be made and adequate controls and protective equipment shall be provided so that the pressure rise due to surges and other variations from normal operations shall not exceed the internal design pressure at any point in the piping system and equipment by more than 10%.

#### 403.4 Criteria to Prevent Buckling and Excessive Ovality

The pipeline system shall be designed and installed in a manner to prevent local buckling or excessive ovality of the pipe, collapse, and column buckling during installation and operations. Design, installation, and operating procedures shall consider the effect of external pressure; bending, axial, and torsional loads; impact; mill tolerances in the wall thickness; out-of-roundness; and other applicable factors. Consideration shall also be given to mitigation of propagation buckling that may follow local buckling or denting. The pipe wall thickness shall be selected to resist collapse due to external pressure.

#### 403.5 Criteria to Prevent Fatigue

The pipeline shall be designed, installed, and operated to limit stress fluctuations to magnitudes and frequencies that will not impair the serviceability of the pipeline. Loads that may cause fatigue include internal pressure variations, currents, and vibrations induced by vortex shedding. Pipeline spans shall be designed to prevent vortex-induced resonant vibrations when practical. When vibrations must be tolerated, the resulting stresses due to vibration shall be included in allowable stresses listed in [para. 403.3.1](#). If alternative acceptance standards for girth welds in API 1104 are used, the cyclic stress analysis shall include the determination of a predicted fatigue spectrum to which the pipeline is exposed over its design life. See Chapter 2 of ASME B31.3 for guidance.

#### 403.6 Criteria to Prevent Loss of In-Place Stability

**403.6.1 Strength Criteria During Installation and Testing.** Design against loss of in-place stability shall be in accordance with the provisions of [para. 403.6.2](#), except that the installation design current conditions shall be based on the provisions of [para. 401.3](#). If the pipeline is to be trenched, it shall be designed for stability during the period prior to trenching.

##### 403.6.2 Strength Criteria During Operations

**403.6.2.1 General.** Pipeline design for lateral and vertical on-bottom stability is governed by permanent features such as topography and soil characteristics and by transient events such as hydrodynamic, seismic, and soil behavior events that are likely to occur during the anticipated service life. Design conditions to be considered are provided in [paras. 403.6.2.2](#) through [403.6.2.7](#).

The pipeline shall be designed to prevent horizontal and vertical movements or shall be designed so that any movements will be limited to values not causing allowable stresses and strains to be exceeded.

(a) Typical factors to be considered in the stability design include

- (1) flood plains and marshes and other locations subject to immersed conditions
- (2) current forces
- (3) soil properties
- (4) scour and resultant spanning
- (5) soil liquefaction
- (6) slope failure

(b) Stability may be obtained by such means as, but not limited to

- (1) adjusting pipe submerged weight
- (2) trenching and/or covering of pipe
- (3) anchoring
- (4) clamp-on or set-on weights

Installation and operational on-bottom stability design conditions shall be considered.

**403.6.2.2 Design Current Conditions.** Operational design current conditions shall be based on an event having a minimum return interval of not less than 100 yr.

**403.6.2.3 Stability Against Currents.** The submerged weight of the pipe shall be designed to resist or limit movement to amounts that do not cause the longitudinal and combined stresses to exceed the limits specified in [Table 403.3.1-1](#). The submerged weight may be adjusted by weight coating and/or increasing pipe wall thickness.

Current direction shall be considered.

The pipeline and its appurtenances may be buried to enhance stability.

Backfill or other protective covering options shall use materials and procedures that minimize damage to the pipeline and coatings.

Anchoring may be used alone or in conjunction with other options to maintain stability. The anchors shall be designed to withstand lateral and vertical loads expected from the design wave and current conditions. Anchors shall be spaced to prevent excessive stresses in the pipe. Scour shall be considered in the design of the anchoring system. The effect of anchors on the cathodic protection system shall be considered.

Intermittent block type, clamp-on, or set-on weights (river weights) shall not be used on pipelines where there is a potential for the weight to become unsupported because of scour.

**403.6.2.4 Shore Approaches.** Pipe in the shore approach zone shall be installed on a suitable above-water structure or buried or bored to the depth necessary to prevent scouring, spanning, or stability problems that may affect integrity and safe operation of the pipeline during its anticipated service life. Seasonal variation in



the near-shore thickness of seafloor sediments and shoreline erosion over the pipeline service life shall be considered.

**403.6.2.5 Slope Failure and Soil Liquefaction.** Slope failure shall be considered in zones where it is expected (mudslides, steep slopes, areas of seismic slumping). If it is not practical to design the pipeline system to survive the event, the pipeline shall be designed for controlled breakaway with provisions to minimize loss of the pipeline contents.

Design for the effects of liquefaction shall be performed for areas of known or expected occurrence. Soil liquefaction normally results from cyclic wave overpressures or seismic loading of susceptible soils. The bulk specific gravity of the pipeline shall be selected, or alternative methods shall be selected to ensure both horizontal and vertical stability.

Seismic design conditions used to predict the occurrence of bottom liquefaction or slope failure shall be at least as severe as those used for the operating design strength calculations for the pipeline. Occurrence of soil liquefaction due to hydrostatic overpressures shall be based on a minimum storm return interval of not less than 100 yr.

**403.6.2.6 Earthquake-Prone Areas.** When a pipeline is to be laid across a known fault zone or in an earthquake-prone area, consideration shall be given to the need for flexibility in the pipeline and its components to minimize the possibility of damage due to an earthquake. Flexibility in the pipeline may be provided by installation of the pipeline on or above the ground level or by use of breakaway coupling, slack loops, flexible pipe sections, or other site-specific solutions. Breakaway couplings shall be designed to prevent loss of the transported fluid in the event of a separation of the coupling.

**403.6.2.7 Pipe-Soil Interaction.** The pipe-soil interaction factors that are used shall be representative of the soil conditions at the site and pipe coating.

## 403.7 Criteria to Prevent Fracture

**403.7.1 General.** Prevention of fractures during installation and operation shall be considered in material selection in accordance with the requirements of [section 423](#). Welding procedures and weld defect acceptance criteria shall consider the need to prevent fractures during installation and operation. See [para. 434.8.5](#).

**403.7.2 Design Considerations.** The probability of brittle and ductile propagating fractures shall be considered in the design of pipelines transporting liquids that become gases at or near atmospheric conditions. Protection shall be provided to limit the occurrence and the length of fractures throughout the pipeline with special consideration at industrial areas, residential areas,

commercial areas, river crossings, road and railroad crossings, and other appropriate areas.

**403.7.3 Brittle Fractures.** Brittle fracture propagation shall be prevented by selection of a pipe steel that fractures in a ductile manner at operating temperatures.

**403.7.4 Ductile Fractures.** Ductile fracture propagation shall be minimized by the selection of a pipe steel with appropriate fracture toughness and/or by the installation of suitable fracture arrestors. See ASME B31T for more information about determining appropriate toughness of pipe steel. Design consideration shall include pipe diameter, wall thickness, fracture toughness, yield strength, operating pressure, operating temperature, and the decompression characteristics of the pipeline contents.

## 403.8 Criteria for Crossings

**403.8.1 General.** Crossing of water, railroads, roads, foreign pipelines, and utilities requires variations in basic pipeline design. The location of buried pipelines, utility lines, and other underground structures along and crossing the proposed right of way shall be determined and considered in the design.

**403.8.2 Trenched Water Crossings.** Design of crossings of rivers, streams, lakes, and inland bodies of water shall include investigation of the composition of bottom and underlying layers, variation in banks, velocity of water, scouring, and special seasonal conditions.

Where required, detailed plans and specifications shall be prepared, taking into account these and any special considerations or limitations imposed by the regulatory bodies involved. Plans and specifications shall describe the position of the line showing the depth below mean low water level when applicable.

Thicker wall pipe may be specified. Approach and position of the line in the banks is important, as is the position of the line across the bottom. Special considerations shall be given to depth of cover and other means of protecting the pipeline in the shore and bank crossings.

Special consideration shall be given to protective coatings and the use of weight coating, river weights, and anchors.

**403.8.3 Directionally Drilled Crossings.** Specific consideration shall be given to stresses and dynamic loads associated with the installation of directionally drilled crossings, including axial loading, yielding, buckling, bending, and other dynamic loads or a combination of these loads. Calculated stresses in the pipe and attachments shall not exceed the allowable limits identified in [Table 403.3.1-1](#), including residual bending stresses.

Designs shall include selection of the location of entry and exit points of the proposed installation, clearances at points of crossing of other underground facilities, and

spacing between the directionally drilled crossing and parallel underground pipelines, utilities, and cables.

In finalizing the proposed pipeline routing, each operator shall

(a) conduct a site survey to identify pipelines, utilities, cables, and other nearby subsurface structures that may potentially be affected by the drilling and installation operations

(b) contact and communicate with other facility owners identified in (a)

(c) physically locate and mark all nearby or parallel pipelines, utilities, cables, and other underground structures within 100 ft (30 m) of the drilling operation

(d) analyze the accuracy of the method specified for tracking the position of the pilot string during drilling, including the effect on the tracking system of parallel power or communication lines (above- or belowground) and cathodic protection systems operating in the vicinity

(e) conduct soil borings and geotechnical evaluations if subsurface conditions are unknown

**403.8.4 Overhead Crossings.** Overhead suspended bridges or other overhead structures used to suspend pipelines shall be designed and constructed within the restrictions or regulations of the regulatory body having jurisdiction. Suspension bridges, prefabricated steel bridges, reinforced concrete bridges, and self-spanning pipe bridges may be used. Stresses produced by the pipe weight, environmental loads, and other predictable loads shall not exceed the maximum stresses allowed by this Code. Detailed plans and specifications shall be prepared where required.

Design of overhead crossings using a dedicated bridge with self-supporting spans that are specially designed for the pipeline crossing shall consider the following:

(a) pipe and content weight

(b) external loads such as wind, snow, and ice

(c) flooding

(d) thermal stresses

(e) electrical isolation of pipeline from supporting steel structure to prevent interference with pipeline cathodic protection

(f) atmospheric corrosion control

**403.8.5 Crossings Attached to Bridges.** In addition to structural support concerns, the differential movement between the bridge and pipeline due to thermal stresses and external loads shall be considered in the design of the pipeline crossing. In addition to the design considerations listed in para. 403.8.4, consideration shall be given to special requirements to prevent damage to the pipeline from vehicles, deicing chemicals, bridge components, and other site-specific hazards.

**403.8.6 Railroad and Highway Crossings.** Stresses due to internal design pressure and external load in pipe installed under railroads or highways without use of casing shall not exceed the allowable stresses specified

in Table 403.3.1-1. Installation of uncased carrier pipe is preferred. Installation of carrier, or casing if used, may be in accordance with API RP 1102 or other appropriate standard. If casing is used, coated carrier pipe shall be independently supported outside each end of the casing and insulated from the casing throughout the cased section, and casing ends shall be sealed using a durable, electrically nonconductive material.

**403.8.7 Crossings of Pipelines and Utilities.** Pipeline crossings should be designed to provide a minimum 12-in. (300-mm) separation between the pipeline and other pipelines and utilities, unless other measures of protection are provided. Soil settlement, scour, and cyclical loads shall be considered in the design of pipeline crossings in order to ensure that the separation is maintained for the design life of both lines. Consideration shall be given to the support of other pipelines and utilities during and following construction.

#### 403.9 Criteria for Expansion and Flexibility

**403.9.1 Unrestrained Pipelines.** Pipelines shall be designed to have sufficient flexibility to prevent expansion or contraction from causing stresses in the pipe material or pipeline components that exceed the allowables specified herein, including joints, connections, anchor points, or guide points. (19)

NOTE: Allowable forces and moments on equipment may be less than for the connected pipe.

Analysis of adequate flexibility of unrestrained pipe is not required for a pipeline that

(a) has been previously analyzed

(b) is of uniform size, has no more than two anchor points and no intermediate restraints, and falls within the limitations of the following empirical formula:

$$Dy/(L - U)^2 \leq K$$

where

$D$  = outside diameter of the pipe, in. (mm)

$K$  = 0.03 for U.S. customary units listed above

= 208 for SI units listed above

$L$  = developed length of the pipe between anchors, ft (m)

$U$  = straight line distance between anchors, ft (m)

$y$  = resultant of total displacement strains, in. (mm), to be absorbed by the pipe ( $U\alpha\Delta T$ )

Any pipeline not meeting the requirements given above shall be analyzed by a simplified, approximate, or comprehensive method as appropriate. The effects of all parts of the pipeline and components and of all restraints, including friction, shall be accounted for.

**403.9.2 Restrained Buried Pipelines.** Buried pipelines are considered restrained. Stress calculations are necessary for buried pipelines whenever significant

temperature changes are expected or the pipeline deviates from a straight line. Safe operation of a buried pipeline is predicated on the assumption that the pipeline is maintained in its position in the ground through support of the soil below and on the sides. The pipeline must also be provided with proper soil cover to prohibit it from rising out of the ground at over bends. The buoyancy effects on a submerged pipeline shall be considered in its stability. At the ends of a buried pipeline, thermal and pressure forces may cause significant longitudinal movement of the pipe, as the soil is normally unable to provide the restraint to prevent movement. The length of the pipeline subject to axial movement may be several hundred feet, and the end of the pipeline should be either anchored to prevent movement or designed to accommodate movement at the end of the pipeline.

Buried sections of pipe that are not fully restrained, such as in a pump station, will move through the soil and should be analyzed for overstressing by reaction with the soil. Guidance regarding soil-pipe interaction can be found in the ASCE publication American Lifelines Alliance "Guidelines for the Design of Buried Pipelines," July 2001 (with addenda through February 2005) and ASME B31.1, Nonmandatory Appendix VII.

#### **403.9.3 Restrained Aboveground Pipelines.**

Restrained aboveground pipelines should be anchored so that longitudinal expansion or contraction due to thermal and pressure changes is absorbed by direct axial compression or tension. Consideration shall also be given to beam bending stress and the possible elastic instability of the pipe and its supports due to longitudinal compressive forces. The supports shall be designed to provide the stiffness necessary to prevent lateral buckling.

#### **403.10 Criteria for Used Pipe**

Used pipe of known specification listed in [Table 403.2.1-1](#) may be utilized in accordance with the design equations in [section 402](#) of this Code, subject to the criteria in this section, and the testing requirements of [paras. 437.4.1, 437.6.1, 437.6.3, and 437.6.4](#).

#### **403.11 Criteria for Cold Worked Pipe**

The allowable stress for pipe that has been cold worked to meet the specified minimum yield strength and is subsequently heated to 600°F (300°C) or higher (welding excepted) shall be derated to 75% of the allowable stress value as defined in [para. 403.2.1](#).

#### **403.12 Criteria for Shear and Bearing Stresses**

Allowable stress values in shear shall not exceed 45% of the specified minimum yield strength of the pipe, and allowable stress values in bearing shall not exceed 90% of the specified minimum yield strength of the pipe.

#### **403.13 Criteria for Structural Supports and Restraints**

Allowable tensile and compressive stress values for materials used in structural supports and restraints shall not exceed 66% of the specified minimum yield strength. Allowable stress values in shear and bearing shall not exceed 45% and 90% of the specified minimum yield strength, respectively. Steel materials of unknown specifications may be used for structural supports and restraints, provided a yield strength of 24,000 psi (165 MPa) or less is used.

### **404 CRITERIA FOR FITTINGS, ASSEMBLIES, AND OTHER COMPONENTS (ALTERNATIVELY, CRITERIA FOR COMPONENTS)**

#### **404.1 General Criteria for Piping Components**

**404.1.1 Steel Butt Welding Fittings.** When steel butt welding fittings (see [paras. 404.2.5 and 404.3.2](#)) are used, they shall comply with ASME B16.9, ASME B16.28, or MSS SP-75.

**404.1.2 Components Having Specific Pressure-Temperature Ratings.** Within the metal temperature limits of -20°F (-30°C) to 250°F (120°C), pressure ratings for components shall conform to those stated for 100°F (40°C) in material standards and specifications listed in [Table 423.1-1](#). The nonmetallic trim, packing, seals, and gaskets shall be made of materials that are not injuriously affected by the fluid in the piping system and shall be capable of withstanding the pressures and temperatures to which they will be subjected in service. Consideration shall be given to possible conditions that may cause low temperatures on pipelines transporting liquids that become gases at or near atmospheric conditions. (19)

**404.1.3 Ratings — Components Not Having Specific Pressure-Temperature Ratings.** Piping components not having established pressure ratings may be qualified for use as specified in [paras. 404.10 and 423.1\(b\)](#).

**404.1.4 Pressure Criteria.** The piping component at any point in the pipeline system shall be designed for an internal design pressure that shall not be less than the maximum steady-state operating pressure at that point, or less than the static head pressure at that point with the line in a static condition. The maximum steady-state operating pressure shall be the sum of the static head pressure, pressure required to overcome friction losses, and any required back pressure. Credit may be given for hydrostatic external pressure, in the appropriate manner, in modifying the internal design pressure for use in calculations involving the pressure design of piping components. Pressure rise above maximum steady-state operating pressure due to surges and other

variations from normal operations is allowed in accordance with [para. 404.1.5](#).

Provision shall be made in the design either to withstand or to relieve increased pressure caused by the heating of static fluid in a piping component.

The piping component shall be designed to withstand the maximum possible differential between external and internal pressures to which the component will be exposed.

**404.1.5 Overpressure Criteria.** The pressure rise due to surges (see [para. 403.3.4](#)) and other variations from normal operations shall not exceed the internal design pressure at any point in the piping system and equipment by more than 10%.

**404.1.6 Ratings — Considerations for Different Pressure Conditions.** When two lines that operate at different pressure conditions are connected, the valve segregating the two lines shall be rated for the more severe service condition. When a line is connected to a piece of equipment that operates at a higher pressure condition than that of the line, the valve segregating the line from the equipment shall be rated for at least the operating condition of the equipment. The piping between the more severe conditions and the valve shall be designed to withstand the operating conditions of the equipment or piping to which it is connected.

**404.1.7 Fittings Exceeding Scope of Standard Sizes.** Fittings exceeding scope of standard sizes or otherwise departing from dimensions listed in the standards referred to in [paras. 404.1.1](#) and [404.4.1](#) may be used, provided the designs meet the requirements of this Code.

**404.1.8 Special Fittings and Connections.** Cast, forged, wrought, or welded steel fittings different from those specified in the applicable American National Standards and MSS Standard Practices will be permitted, provided that their design is in accordance with [para. 404.10](#).

**404.1.9 Thermowells.** Thermowells shall comply with ASME PTC 19.3 TW.

## 404.2 Directional Changes

**404.2.1 General.** Changes in direction, vertically and horizontally, may be made by field bending the pipe, by inserting induction bends (also called hot bends), or by installing manufactured bends or elbows.

The minimum wall thickness of pipe before bending, field bends, or induction bends shall be determined as for straight pipe in accordance with [para. 403.2.1](#).

**404.2.2 Field Bends.** Field bends are cold bends, generally made in the field during construction, to allow the pipe to conform to the contour of the ditch. Field bends include vertical bends (sags and overbends),

horizontal bends to accommodate changes in direction, and combination bends.

Bends shall be free from buckling, cracks, or other evidence of mechanical damage. Ripples or wrinkles meeting the requirements of [para. 451.6.2.8](#) are acceptable.

Field bends shall meet the requirements of [para. 434.7.1](#).

The minimum radius of field cold bends, except as noted in the next two paragraphs, shall be as follows:

Nominal Pipe Size	Minimum Radius of Bend in Pipe Diameters
NPS 12 and smaller	18D
14	21
16	24
18	27
NPS 20 and larger	30

In some cases, thin wall pipe will require the use of an internal mandrel when being bent to the minimum radii tabulated above.

Bends may be made by bending the pipe in sizes NPS 14 and larger to a minimum radius of 18D. However, bending pipe to radii approaching 18D shall comply with the criteria in this paragraph and will be dependent on wall thickness, ductility, ratio of pipe diameter to wall thickness, use of bending mandrel, and skill of bending crew. Test bends shall be made to determine that the field bending procedure used produces bends meeting the requirements of this paragraph and that the wall thickness after bending is not less than the minimum permitted by the pipe specification.

Cold bends should have tangents on each end in accordance with [para. 434.7.1\(d\)](#).

**404.2.3 Induction Bends.** Induction bends are made by heating the pipe and forming the bend under controlled conditions. The minimum wall thickness of pipe before bending shall be determined as for straight pipe in accordance with [para. 403.2.1](#). Induction bends shall comply with ASME B16.49. (19)

Bends shall be free from buckling, cracks, or other evidence of mechanical damage. Ripples or wrinkles meeting the requirements of [para. 451.6.2.8](#) are acceptable.

The pipe diameter shall not be reduced at any point by more than 2½% of the nominal diameter, and the completed bend shall pass the specified sizing pig.

When hot bends are made in pipe that has been cold worked in order to meet the specified minimum yield strength, wall thickness shall be determined by using the lower stress values in accordance with [para. 403.11](#).

**404.2.4 Mitered Bends.** In systems intended to operate at a hoop stress of more than 20% of the specified minimum yield strength of the pipe, miter bends are



prohibited. Miter bends not exceeding  $12\frac{1}{2}$  deg may be used in systems operated at a hoop stress of 20% or less of the specified minimum yield strength of the pipe, and the minimum distance between miters measured at the crotch shall not be less than one pipe diameter. When the system is to be operated at a hoop stress of less than 10% of the specified minimum yield strength of the pipe, the restriction to  $12\frac{1}{2}$  deg maximum miter and distance between miters will not apply. Deflections caused by misalignment up to 3 deg are not considered miter bends.

Care shall be taken in making mitered joints to provide proper spacing and alignment and full-penetration welds.

**404.2.5 Factory-Made Bends and Elbows.** The minimum metal thickness of flanged or threaded elbows shall not be less than specified for the pressures and temperatures in the applicable ASME Standard or the MSS Standard Practice.

Steel butt welding elbows shall comply with ASME B16.9, ASME B16.28, or MSS SP-75, and shall have pressure and temperature ratings based on the same stress values as were used in establishing the pressure and temperature limitations for pipe of the same or equivalent materials.

Factory-made bends and elbows shall have approximately the same mechanical properties and chemical composition as the pipe to which they are welded.

Transverse segments cut from factory-made wrought steel welding bends and factory-made elbows may be used for changes in direction, provided the arc distance measured along the crotch is at least 2 in. (50 mm) on pipe size NPS 4 and larger.

If the internal diameter of factory-made bends and elbows differs by more than  $\frac{3}{16}$  in. (5 mm) from that of the pipe, the fitting shall be treated as indicated in Figure 434.8.6-2 or use a transition nipple not less than one-half pipe diameter in length with acceptable joint designs as illustrated in Figure 434.8.6-2.

If factory-made elbows are used in cross-country lines, care shall be taken to allow for passage of in-line inspection tools.

**404.2.6 Wrinkle Bends.** Wrinkle bends shall not be used.

### 404.3 Branch Connections

**404.3.1 General.** Branch connections may be made by means of tees, crosses, integrally reinforced extruded outlet headers, or welded connections, and shall be designed in accordance with the requirements of this paragraph.

**404.3.2 Tees and Crosses.** Steel butt welding tees and crosses may be used for all ratios of branch diameter to header diameter and all ratios of design hoop stress to specified minimum yield strength of the adjoining header and branch pipe, provided they comply with

ASME B16.9, ASME B16.28, or MSS SP-75. Pressure and temperature ratings shall be based on the same stress values as were used in establishing the pressure and temperature limitations for pipe of the same or equivalent material.

The minimum metal thickness of flanged or threaded tees and crosses shall not be less than specified for the pressures and temperatures in the applicable ASME Standard or the MSS Standard Practice.

### 404.3.3 Integrally Reinforced Extruded Outlet Headers

**404.3.3.1 Definition.** An extruded outlet header is defined as a header in which the extruded lip at the outlet has a height above the surface of the header that is equal to or greater than the radius of curvature of the external contoured portion of the outlet, i.e.,  $h_o \geq r_o$ . See Figure 404.3.3.1-1.

These rules do not apply to any nozzle in which additional nonintegral material is applied in the form of rings, pads, or saddles.

These rules apply only to cases where the axis of the outlet intersects and is perpendicular to the axis of the header.

**404.3.3.2 Notation.** The notation used herein is illustrated in Figure 404.3.3.1-1. All dimensions are in inches (millimeters).

$D$  = outside diameter of header

$d$  = outside diameter of branch pipe

$D_c$  = internal diameter of header

$d_c$  = internal diameter of branch pipe

$D_o$  = internal diameter of extruded outlet measured at the level of the outside surface of header

$h_o$  = height of the extruded lip. This must be equal to or greater than  $r_o$ , except as shown in  $r_o$  below.

$L$  = height of the reinforcement zone

$$= 0.7\sqrt{dT_o}$$

$r_o$  = radius of curvature of external contoured portion of outlet measured in the plane containing the axes of the header and branch. This is subject to the following limitations:

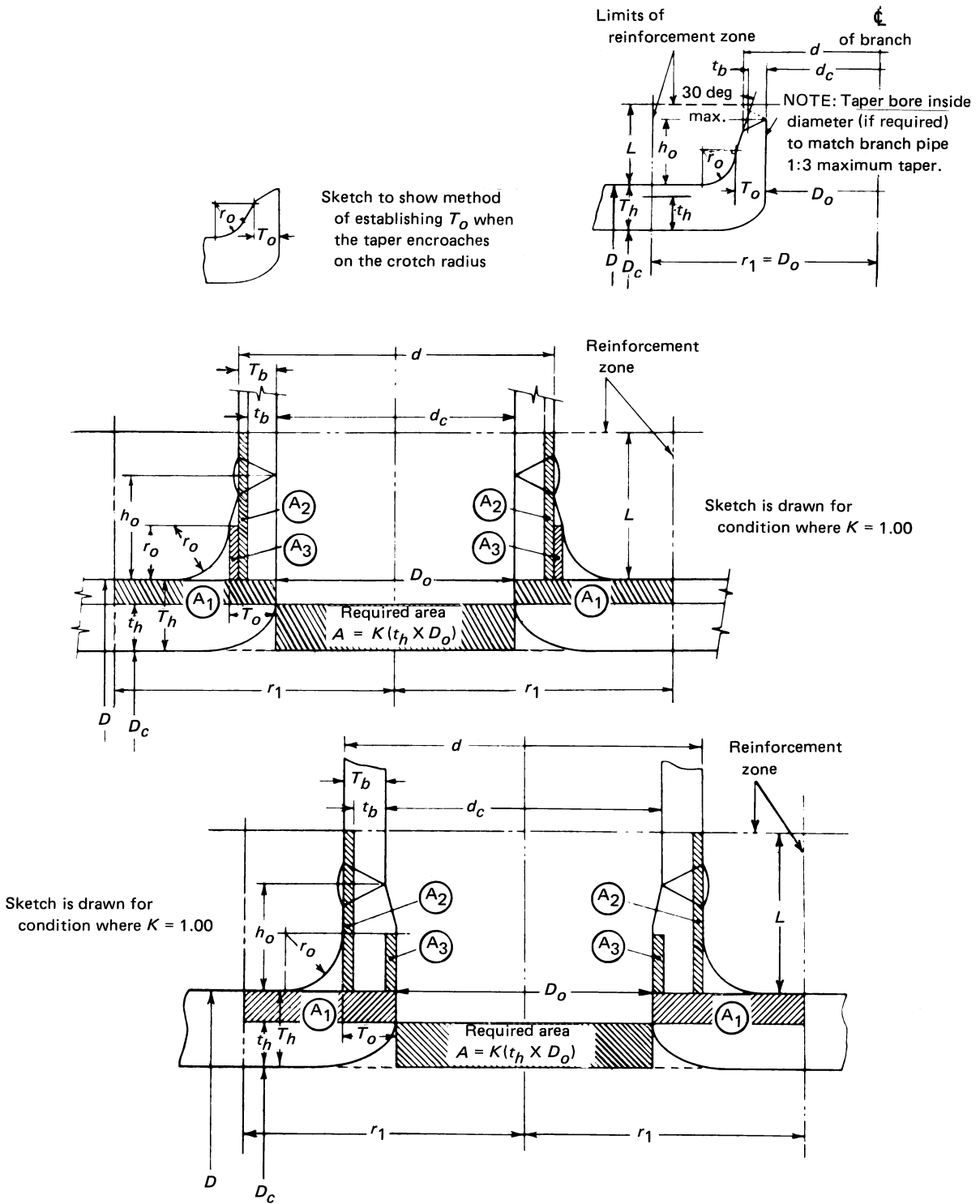
(a) Minimum radius shall not be less than  $0.05d$ , except that on branch diameters larger than NPS 30 it need not exceed 1.50 in. (38 mm).

(b) Maximum radius for outlet pipe sizes NPS 8 and larger shall not exceed  $0.10d + 0.50$  in. (13 mm). For outlet pipe sizes less than NPS 8, this dimension shall not be greater than 1.25 in. (32 mm).

(c) When the external contour contains more than one radius, the radius of any arc sector of approximately 45 deg shall meet the requirements for minimum and maximum radius above.

(d) Machining shall not be employed in order to meet the above requirements.

Figure 404.3.3.1-1 Reinforced Extruded Outlets



- $r_1$  = half-width of reinforcement zone (equal to  $D_o$ )  
 $T_b$  = actual nominal wall thickness of branch  
 $t_b$  = required thickness of the branch pipe according to the wall thickness equation in [para. 403.2.1](#)  
 $T_h$  = actual nominal wall thickness of header  
 $t_h$  = required thickness of the header according to the wall thickness equation in [para. 403.2.1](#)  
 $T_o$  = finished thickness of extruded outlet measured at a height equal to  $r_o$  above the outside surface of the header

**404.3.3.3 Criteria for Use.** Integrally reinforced extruded outlet headers may be used for all ratios of branch diameter to header diameter and all ratios of design hoop stress to specified minimum yield strength of the joining header and branch pipe, provided they comply with this paragraph.

**404.3.3.4 Design.** When the design meets the limitations on geometry contained herein, the rules established are valid and meet the intent of the Code. These rules cover minimum requirements and are selected to ensure satisfactory performance of extruded headers subjected to pressure. Extruded headers shall be designed to withstand forces and moments applied to the branch by thermal expansion and contraction; by vibration; by deadweight of piping, valves, fittings, covering, and contents; and by earth settlement.

**404.3.3.5 Required Area.** The required area is defined as  $A = K(t_h D_o)$ , where  $K$  shall be taken as follows:

- (a) for  $d/D > 0.60$ ,  $K = 1.00$   
 (b) for  $d/D > 0.15$  and not exceeding 0.60,  $K = 0.6 + \frac{2}{3}(d/D)$   
 (c) for  $d/D \leq 0.15$ ,  $K = 0.70$

The design must meet the criteria that the reinforcement area defined in [para. 404.3.3.6](#) is not less than the required area.

**404.3.3.6 Reinforcement Area.** The reinforcement area shall be the sum of areas  $A_1 + A_2 + A_3$  as defined below.

(a) *Area  $A_1$ .* The area lying within the reinforcement zone resulting from any excess thickness available in the header wall, i.e.,

$$A_1 = D_o(T_h - t_h)$$

(b) *Area  $A_2$ .* The area lying within the reinforcement zone resulting from any excess thickness available in the branch pipe wall, i.e.,

$$A_2 = 2L(T_b - t_b)$$

(c) *Area  $A_3$ .* The area lying within the reinforcement zone resulting from excess thickness available in the extruded outlet lip, i.e.,

$$A_3 = 2r_o(T_o - T_b)$$

**404.3.3.7 Reinforcement of Multiple Openings.** The requirements outlined in [para. 404.3.6](#) shall be followed, except that the required area and reinforcement area shall be as given in [paras. 404.3.3.5](#) and [404.3.3.6](#).

**404.3.3.8 Marking.** The manufacturer shall be responsible for establishing and marking on the section containing extruded outlets the design pressure and temperature, "Established under provisions of ASME B31.4," and the manufacturer's name or trademark.

**404.3.4 Welded Branch Connections.** Welded branch connections shall be as shown in [Figures 404.3.4-1](#), [404.3.4-2](#), and [404.3.4-3](#). Design shall meet the minimum requirements listed in [Table 404.3.4-1](#) and described in (a) through (d) below. Where reinforcement is required, (e) and (f) shall apply.

(a) Smoothly contoured wrought tees or crosses of proven design or integrally reinforced extruded headers are preferred. When such tees, crosses, or headers are not used, the reinforcing member shall extend completely around the circumference of the header (see [Figure 404.3.4-1](#) for typical constructions). Whenever possible, the inside edges of the finished opening shall be rounded to a  $\frac{1}{8}$  in. (3 mm) radius. If the encircling member is thicker than the header and its ends are to be welded to the header, the ends shall be chamfered (at approximately 45 deg) down to a thickness not in excess of the header thickness, and continuous fillet welds shall be made. Pads, partial saddles, or other types of localized reinforcements are prohibited.

(b) The reinforcement member may be of the complete encirclement type (see [Figure 404.3.4-1](#)), pad or saddle type (see [Figure 404.3.4-2](#)), or welding outlet fitting type. Where attached to the header by fillet welding, the edges of the reinforcement member shall be chamfered (at approximately 45 deg) down to a thickness not in excess of the header thickness. The diameter of the hole cut in the header pipe for a branch connection shall not exceed the outside diameter of the branch connection by more than  $\frac{1}{4}$  in. (6.4 mm).

(c) Reinforcement for branch connections with hole cut NPS 2 or smaller is not required (see [Figure 404.3.4-3](#) for typical details); however, care shall be taken to provide suitable protection against vibrations and other external forces to which these small branch connections are frequently subjected.

(d) Reinforcement of opening is not mandatory; however, reinforcement may be required for cases involving pressure over 100 psi (7 bar), thin wall pipe, or severe external loads.

(e) If a reinforcement member is required, and the branch diameter is such that a localized type of reinforcement member would extend around more than half the circumference of the header, then a complete encirclement type of reinforcement member shall be used, regardless of the design hoop stress, or a smoothly contoured

wrought steel tee or cross of proven design or extruded header may be used.

(f) The reinforcement shall be designed in accordance with para. 404.3.5.

#### 404.3.5 Reinforcement of Single Openings

(a) When welded branch connections are made to pipe in the form of a single connection, or in a header or manifold as a series of connections, the design shall be adequate to control the stress levels in the pipe within safe limits. The construction shall take cognizance of the stresses in the remaining pipe wall due to the opening in the pipe or header, the shear stresses produced by the pressure acting on the area of the branch opening, and any external loading due to thermal movement, weight, vibration, etc., and shall meet the minimum requirements listed in Table 404.3.4-1. The following paragraphs provide design rules based on the stress intensification created by the existence of a hole in an otherwise symmetrical section. External loadings, such as those due to thermal expansion or unsupported weight of connecting pipe, have not been evaluated. These factors should be given attention in unusual designs or under conditions of cyclic loading.

When pipe that has been cold worked to meet the specified minimum yield strength is used as a header containing single or multiple welded branch connections, stresses shall be in accordance with para. 403.12.

(b) The reinforcement required in the crotch section of a welded branch connection shall be determined by the rule that the metal area available for reinforcement shall be equal to or greater than the required cross-sectional area as defined in (d)(3) and in Figure 404.3.5-1.

(c) The required cross-sectional area,  $A_R$ , is defined as the product of  $d$  times  $t_h$

$$A_R = dt_h$$

where

$d$  = length of the finished opening in the header wall measured parallel to the axis of the header

$t_h$  = design header wall thickness required by para. 403.2.1. For welded pipe, when the branch does not intersect the longitudinal or helical seam weld of the header, the allowable stress value for seamless pipe of comparable grade may be used in determining  $t_h$  for the purpose of reinforcement calculations only. When the branch does intersect the longitudinal or helical seam weld of the header, the allowable stress value,  $S$ , of the header shall be used in the calculation. The allowable stress value,  $S$ , of the branch shall be used in calculating  $t_b$ .

(d) The area available for the reinforcement shall be the sum of

(1) the cross-sectional area resulting from any excess thickness available in the header thickness (over the minimum required for the header as defined in para. 403.2.1) and that lies within the reinforcement area as defined in (e)

(2) the cross-sectional area resulting from any excess thickness available in the branch wall thickness over the minimum thickness required for the branch and that lies within the reinforcement area as defined in (e)

(3) the cross-sectional area of all added reinforcing metal, including weld metal, that is welded to the header wall and lies within the reinforcement area as defined in (e)

(e) The reinforcement area is shown in Figure 404.3.5-1 and is defined as a rectangle whose length shall extend a distance,  $d$  [see (c)], on each side of the transverse centerline of the finished opening and whose width shall extend a distance of  $2\frac{1}{2}$  times the header wall thickness from the outside surface of the header wall, except that in no case shall it extend more than  $2\frac{1}{2}$  times the thickness of the branch wall from the outside surface of the header or of the reinforcement, if any.

(f) The material of any added reinforcement shall have an allowable working stress at least equal to that of the header wall, except that material of lower allowable stress may be used if the area is increased in direct ratio of the allowable stresses for header and reinforcement material, respectively.

(g) The material used for ring or saddle reinforcement may be of specifications differing from those of the pipe, provided the cross-sectional area is made in correct proportions to the relative strength of the pipe and reinforcement materials at the operating temperatures, and provided it has welding qualities comparable to those of the pipe. No credit shall be taken for the additional strength of material having a higher strength than that of the part to be reinforced.

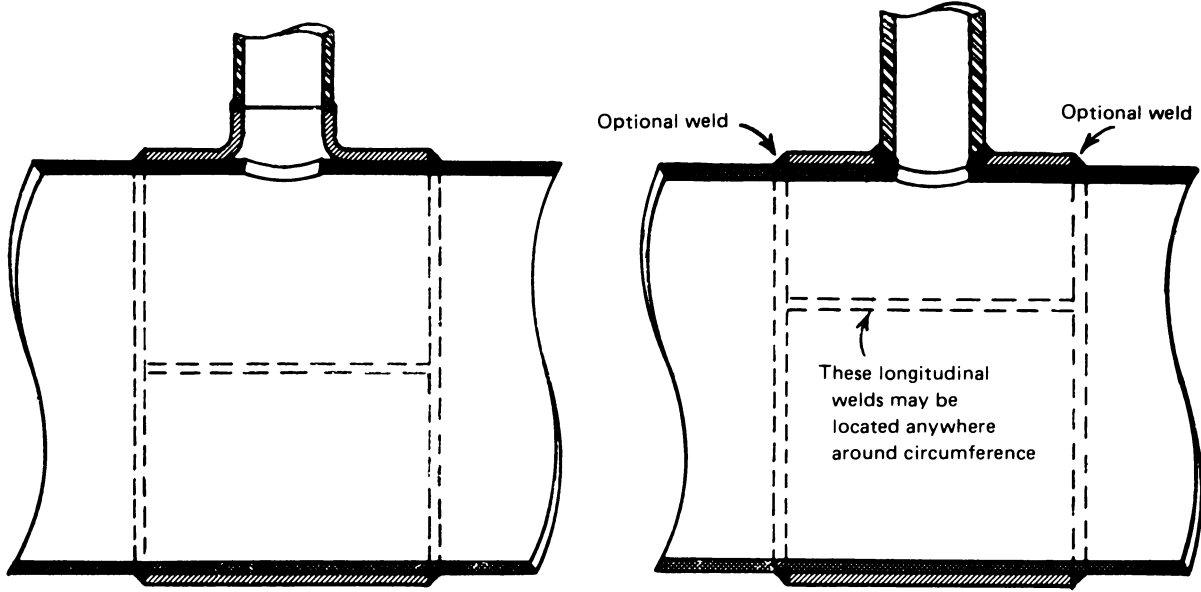
(h) When rings or saddles are used that cover the weld between branch and header, a vent hole shall be provided in the ring or saddle to reveal leakage in the weld between branch and header and to provide venting during welding and heat treating operations. Vent holes shall be plugged during service to prevent crevice corrosion between pipe and reinforcing member, but no plugging material shall be used that would be capable of sustaining pressure within the crevice.

(i) The use of ribs or gussets shall not be considered as contributing to reinforcement to the branch connection. This does not prohibit the use of ribs or gussets for purposes other than reinforcement, such as stiffening.

(j) The branch shall be attached by a weld for the full thickness of the branch or header wall plus a fillet weld,  $W_1$ , as shown in Figures 404.3.4-2 and 404.3.4-3. The use of concave fillet welds is preferred to minimize corner

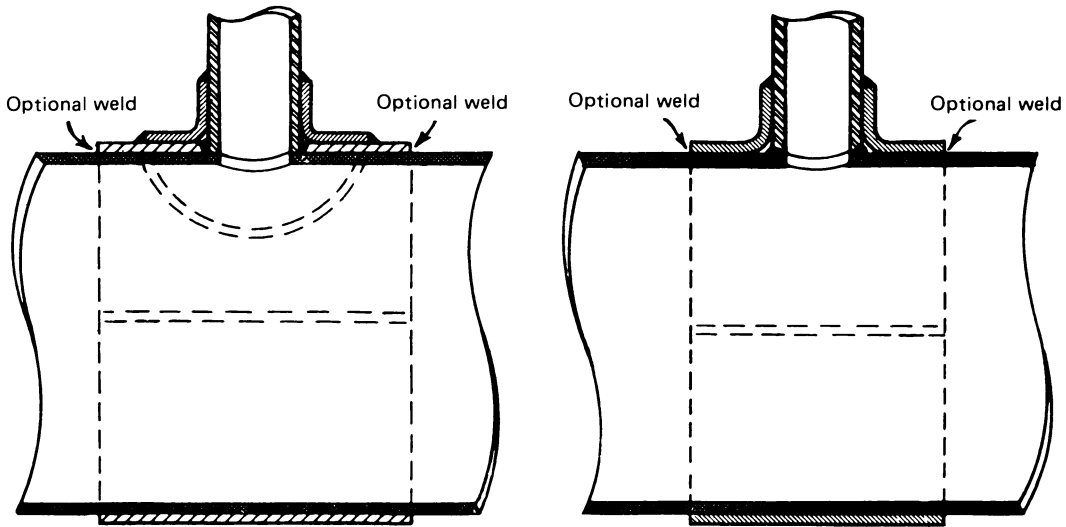


Figure 404.3.4-1 Welding Details for Openings With Complete Encirclement Types of Reinforcement



(a) Tee Type [Note (1)]

(b) Sleeve Type [Note (2)]



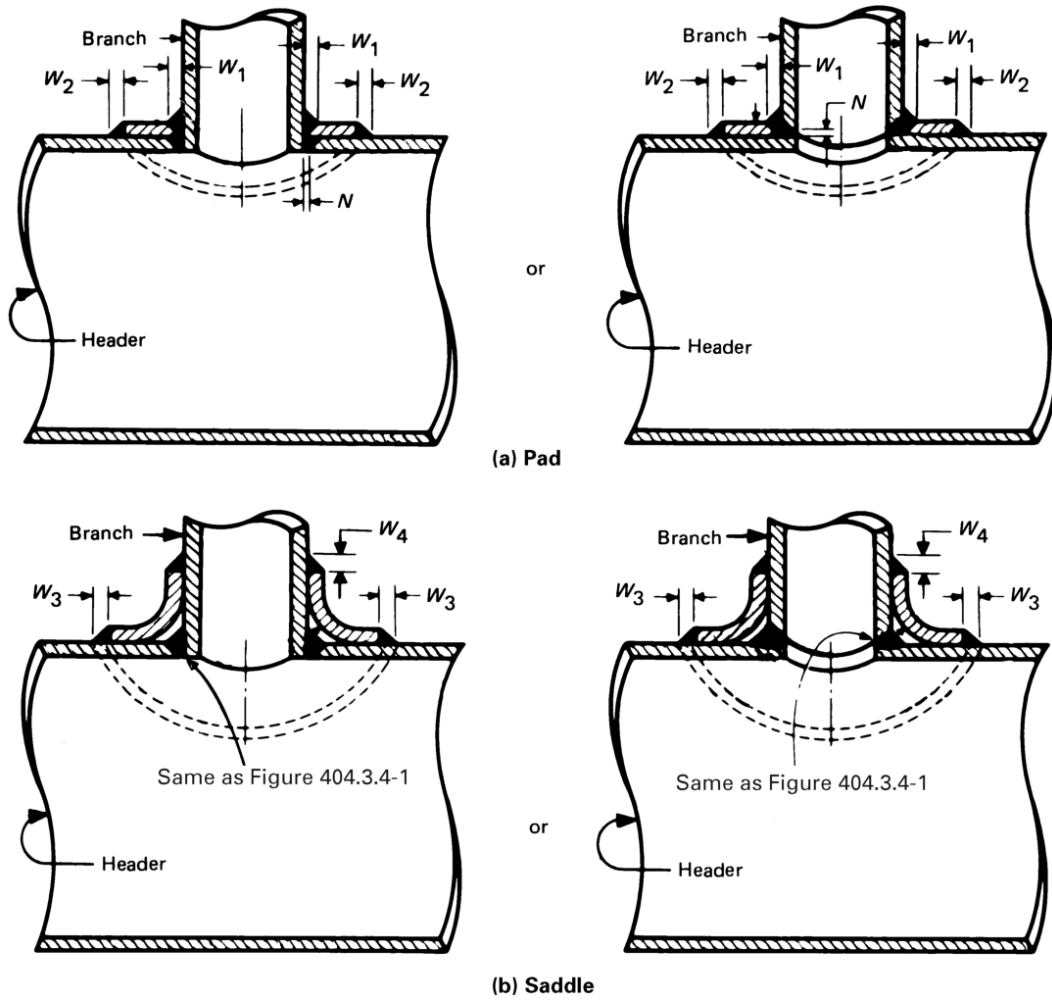
(c) Saddle and Sleeve Type [Note (3)]

(d) Saddle Type [Note (3)]

NOTES:

- (1) Since fluid pressure is exerted on both sides of pipe metal under tee, the pipe metal does not provide reinforcement.
- (2) Provide hole in reinforcement to reveal leakage in buried welds and to provide venting during welding and heat treatment [see [para. 404.3.5\(h\)](#)]. Not required for tee type.
- (3) If the encircling member for tee, sleeve, or saddle type is thicker than the header and its ends are to be welded to the header, the ends shall be chamfered (at approximately 45 deg) down to a thickness not in excess of the header thickness.

Figure 404.3.4-2 Welding Details for Openings With Localized-Type Reinforcement

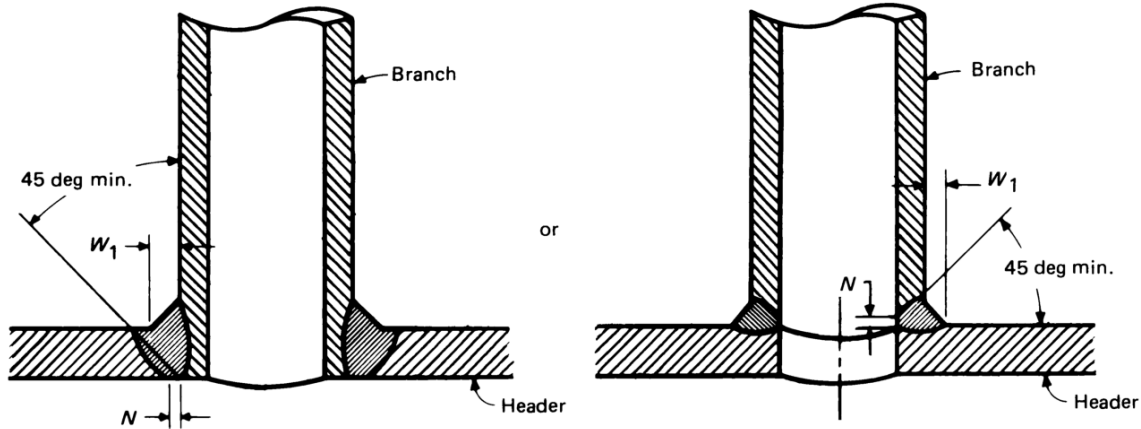


- |   |  |
|---|--|
| $M$ = nominal wall thickness of pad reinforcement member  | $W_1$ (min.) = the smaller of $T_b$ , $M$ , or $\frac{3}{8}$ in. (10 mm)         |
| $M_b$ = nominal wall thickness of saddle at branch end  | $W_2$ (max.) = approximate $T_h$   |
| $M_h$ = nominal wall thickness of saddle at header end  | $W_2$ (min.) = the smaller of $0.7T_h$ , $0.7M$ , or $\frac{1}{2}$ in. (13 mm)   |
| $N$ = $\frac{1}{16}$ in. (1.5 mm) (min.), $\frac{1}{8}$ in. (3 mm) (max.) (unless back welded or backing strip is used) | $W_3$ (max.) = approximate $T_h$   |
| $T_b$ = nominal wall thickness of branch  | $W_3$ (min.) = the smaller of $0.7T_h$ , $0.7M_h$ , or $\frac{1}{2}$ in. (13 mm) |
| $T_h$ = nominal wall thickness of header  | $W_4$ (min.) = the smaller of $T_b$ , $M_b$ , or $\frac{3}{8}$ in. (10 mm)       |

GENERAL NOTES:

- (a) All welds are to have equal leg dimensions and a minimum throat equal to  $0.707 \times$  leg dimension.
- (b) If the reinforcing member is thicker at its edge than the header, the edge shall be chamfered (at approximately 45 deg) down to a thickness such that leg dimensions of the fillet weld shall be within the minimum and maximum dimensions specified above.
- (c) A hole shall be provided in reinforcement to reveal leakage in buried welds and to provide venting during welding and heat treatment [see para. 404.3.5(h)].

**Figure 404.3.4-3 Welding Details for Openings Without Reinforcement Other Than That in Header and Branch Walls**



$N = \frac{1}{16}$  in. (1.5 mm) (min.),  $\frac{1}{8}$  in. (3 mm) (max.) unless back welded or backing strip is used

$T_b$  = nominal wall thickness of branch

$T_h$  = nominal wall thickness of header

$W_1$  (min.) = the smaller of  $T_b$ ,  $T_h$ , or  $\frac{3}{8}$  in. (10 mm)

GENERAL NOTE: When a welding saddle is used, it shall be inserted over this type of connection. See Figure 404.3.4-2.

**Table 404.3.4-1 Design Criteria for Welded Branch Connections**

Ratio of Design Hoop Stress to Specified Minimum Yield Strength of the Header	Ratio of Diameter of Hole Cut for Branch Connection to Nominal Header Diameter		
	25% or less	More Than 25% Through 50%	More Than 50%
20% or less	See para. 404.3.4(d)	See para. 404.3.4(d)	See paras. 404.3.4(d) and 404.3.4(e)
More than 20% through 50%	See paras. 404.3.4(b) and 404.3.4(c)	See para. 404.3.4(b)	See para. 404.3.4(a)
More than 50%	See paras. 404.3.4(b) and 404.3.4(c)	See para. 404.3.4(b)	See para. 404.3.4(a)

stress concentration. Ring or saddle reinforcement shall be attached as shown by Figure 404.3.4-2. If the reinforcing member is thicker at its edge than the header, the edge shall be chamfered (at approximately 45 deg) down to a thickness so leg dimensions of the fillet weld shall be within the minimum and maximum dimensions specified in Figure 404.3.4-2.

(k) Reinforcement rings and saddles shall be accurately fitted to the parts to which they are attached. Figures 404.3.4-1 and 404.3.4-2 illustrate some acceptable forms of reinforcement.

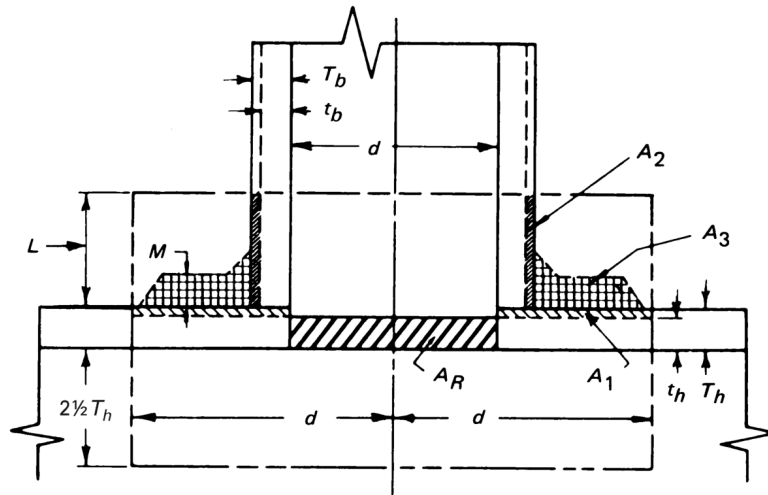
Branch connections attached at an angle less than 90 deg to the header become progressively weaker as the angle decreases. Any such design shall be given individual study, and sufficient reinforcement shall be provided to compensate for the inherent weakness of such construction. The use of encircling ribs to support the flat or reentering surfaces is permissible and may be included in the strength considerations. The designer is cautioned that stress concentrations near the ends of partial ribs, straps, or gussets may defeat their reinforcing value, and their use is not recommended.

**404.3.6 Reinforcement of Multiple Openings**

(a) Two adjacent branches should preferably be spaced at such a distance that their individual effective areas of reinforcement do not overlap. When two or more adjacent branches are spaced at less than 2 times their average diameter (so that their effective areas of reinforcement overlap), the group of openings shall be reinforced in accordance with para. 404.3.5. The reinforcing metal shall be added as a combined reinforcement, the strength of which shall equal the combined strengths of the reinforcements that would be required for the separate openings. In no case shall any portion of a cross section be considered to apply to more than one opening, or be evaluated more than once in a combined area.

(b) When more than two adjacent openings are to be provided with a combined reinforcement, the minimum distance between centers of any two of these openings shall preferably be at least 1½ times their average diameter, and the area of reinforcement between them shall be at least equal to 50% of the total required for these two openings on the cross section being considered.

(19)

**Figure 404.3.5-1 Reinforcement of Branch Connections**

“Area of reinforcement” enclosed by — — — — — lines

$$A_R \leq A_1 + A_2 + A_3 \leq \text{area available as reinforcement}$$

where

$$A_1 = (T_h - t_h)d$$

$$A_2 = 2(T_b - t_b)L$$

$A_3$  = summation of area of all added reinforcement, including weld areas that lie within the “area of reinforcement”

$A_R$  = reinforcement area required

$$= dt_h$$

$d$  = length of finished opening in the header wall (measured parallel to the axis of the header)

$L$  = smaller of  $2\frac{1}{2}T_h$  or  $2\frac{1}{2}T_b + M$

$M$  = actual (by measurement) or nominal thickness of added reinforcement

$T_b$  = nominal wall thickness of branch

$t_b$  = design branch wall thickness required by para. 403.2

$T_h$  = nominal wall thickness of header

$t_h$  = design header wall thickness required by para. 403.2

(c) When two adjacent openings, as considered in (b), have a distance between centers less than  $1\frac{1}{3}$  times their average diameter, no credit for reinforcement shall be given for any of the metal between these two openings.

(d) When pipe that has been cold worked to meet the specified minimum yield strength is used as a header containing single or multiple welded branch connections, stresses shall be in accordance with para. 403.12.

(e) Any number of closely spaced adjacent openings, in any arrangement, may be reinforced as if the group were one assumed opening of a diameter enclosing all such openings.

## 404.4 Flanges

(19) **404.4.1 General.** The design of flanges manufactured in accordance with para. 404.4 and standards or specifications listed in Tables 423.1-1 and 426.1-1 shall be

considered suitable for use at the pressure–temperature ratings as set forth in para. 404.1.2. When steel flanged fittings are used, they shall comply with ASME B16.5.

It is permissible to inside taper bore the hubs on welding neck flanges having dimensions complying with ASME B16.5 when they are to be attached to thin wall pipe. It is recommended that the taper shall not be more abrupt than a ratio of 1:3. Pipeline flanges manufactured in accordance with MSS SP-44 and ASME B16.47 are designed for attachment to thin wall pipe and are preferred for this service.

Where conditions require the use of flanges other than those covered in para. 404.1.2, the flanges shall be designed in accordance with the ASME Boiler and Pressure Vessel Code (BPVC), Section VIII, Division 1, Mandatory Appendix 2. Alternatively, Section VIII, Division 2, Part 5, or Section VIII, Division 3 may be used, provided the required detailed analysis is performed.

**404.4.2 Steel Flanges Within Scope of Standard Sizes.**

Welding neck, slip-on, threaded, and lapped companion flanges, reducing flanges, blind flanges, and flanges cast or forged integral with pipe, fittings, or valves, conforming to ASME B16.5, ASME B16.47, or MSS SP-44, are permitted in the sizes listed in these standards and for the pressure-temperature ratings shown in [para. 404.1.2](#). The bore of welding neck flanges shall correspond to the inside diameter of the pipe with which they are to be used.

**404.4.3 Cast Iron Flanges Within Scope of Standard Sizes.** Cast iron flanges are prohibited, except those that are an integral part of cast iron valves, pressure vessels, and other equipment and proprietary items [see [paras. 404.5.1](#) and [423.2.4\(b\)](#)].

**404.4.4 Flanges Exceeding Scope of Standard Sizes.** Flanges exceeding scope of standard sizes or otherwise departing from ASME B16.5 or MSS SP-44 may be used, provided they are designed in accordance with [para. 404.4.1](#).

**404.4.5 Flanges of Rectangular Cross Section.** Slip-on flanges of rectangular cross section may be used, provided they are designed so that flange thickness is increased to provide strength equal to that of the corresponding hubbed slip-on flange covered by ASME B16.5, as determined by calculations made in accordance with the ASME BPVC, Section VIII, Division 1.

**404.4.6 Flange Facings.** Steel or cast iron flanges shall have contact faces in accordance with ASME B16.1, ASME B16.5, or MSS SP-6.

Special facings are permissible, provided they are capable of withstanding the same tests as those in ASME B16.5. See [para. 404.4.8.3](#) for bolting steel to cast iron flanges.

**404.4.7 Flange Gaskets**

**404.4.7.1 General.** Gaskets shall be made of materials that are not injuriously affected by the fluid in the piping system, and shall be capable of withstanding the pressures and temperatures to which they will be subjected in service.

**404.4.7.2 Standard Gaskets.** Gaskets conforming to ASME B16.20 or ASME B16.21 may be used.

Metallic gaskets other than ring type or helical seam wound shall not be used with ASME Class 150 or lighter flanges.

The use of metal or metal jacketed gasket (either plain or corrugated) is not limited (except as provided in the preceding sentence) as to pressure, provided that the gasket material is suitable for the service temperature.

Gasket groups and typical materials may be used as permitted in Table B-1 of ASME B16.5.

Rings for ring joint gaskets shall be of dimensions established in ASME B16.20. The materials for these rings shall be suitable for the service conditions encountered and shall be softer than the flanges.

**404.4.7.3 Special Gaskets.** Special gaskets, including insulating gaskets, may be used, provided they are suitable for the temperatures, pressures, fluids, and other conditions to which they may be subjected.

**404.4.8 Flange Bolts**

**404.4.8.1 General.** Bolting shall conform to ASME B16.5. Bolts or stud bolts shall extend completely through the nuts. Nuts shall conform to ASTM A194 or ASTM A325, except that ASTM A307 Grade B nuts may be used on ASME Class 150 and ASME Class 300 flanges.

**404.4.8.2 Bolting for Insulating Flanges.** For insulating flanges,  $\frac{1}{8}$  in. (3 mm) undersize bolting may be used, provided that alloy steel bolting material in accordance with ASTM A193 or ASTM A354 is used.

**404.4.8.3 Bolting Steel to Cast Iron Flanges.** When bolting Class 150 steel flanges to Class 125 cast iron flanges, heat treated carbon steel or alloy steel bolting (ASTM A193) may be used only when both flanges are flat face and the gasket is full face; otherwise, the bolting shall have a maximum tensile strength no greater than the maximum tensile strength of ASTM A307 Grade B. When bolting Class 300 steel flanges to Class 250 cast iron flanges, the bolting shall have a maximum tensile strength no greater than the maximum tensile strength of ASTM A307 Grade B. Good practice indicates that the flange should be flat faced.

**404.4.8.4 Bolting for Special Flanges.** For flanges designed in accordance with [para. 404.4.1](#) (see [paras. 404.4.4](#) and [404.4.5](#)), bolting shall conform to the applicable section of the ASME BPVC, Section VIII, Division 1.

**404.5 Valves**

**404.5.1 General.** Steel valves conforming to standards and specifications listed in [Tables 423.1-1](#) and [426.1-1](#) may be used. These valves may contain certain cast, malleable, or wrought iron parts as provided for in API 6D. (19)

Cast iron valves conforming to standards and specifications listed in [Tables 423.1-1](#) and [426.1-1](#) may be used for pressures not to exceed 250 psi (17 bar). Care shall be exercised to prevent excessive mechanical loading (see [para. 404.4.8.3](#)).

Working pressure ratings of the steel parts of steel valves are applicable with the temperature limitations of  $-20^{\circ}\text{F}$  ( $-30^{\circ}\text{C}$ ) to  $250^{\circ}\text{F}$  ( $120^{\circ}\text{C}$ ) (see [para. 401.2.3.7](#)). Where resilient, rubber-like, or plastic materials are used for sealing, they shall be capable of withstanding the fluid, pressure, and temperature specified for the piping system.



**404.5.2 Special Valves.** Special valves not listed in Tables 423.1-1 and 426.1-1 shall be permitted, provided that their design is of at least equal strength and tightness and they are capable of withstanding the same test requirements as covered in these standards, and structural features satisfy the material specification and test procedures of valves in similar service set forth in the listed standards.

## 404.6 Reducers

**404.6.1 Manufactured Reducers.** Reductions in line size may be made by the use of smoothly contoured reducers manufactured in accordance with ASME B16.5, ASME B16.9, or MSS SP-75. Reducer fittings shall have pressure-temperature ratings based on the same stress values as were used in establishing the pressure-temperature limitations for pipe of the same or equivalent material.

Where appropriate, changes in diameter may be accomplished by reducing elbows, reducing outlet tees, or valves.

**404.6.2 Fabricated Reducers.** Fabricated reducers shall conform to the requirements of para. 404.10. Seam welds of fabricated reducers shall be visually inspected and inspected by radiography or ultrasonic shear wave techniques.

**404.6.3 Orange Peel Swages.** Orange peel swages are prohibited in systems operating at hoop stresses of more than 20% of the specified minimum yield strength of the pipe. Seam welds shall be visually inspected.

## 404.7 Closures

**404.7.1 Quick-Opening Closures.** A quick-opening closure is a pressure-containing component (see para. 404.10) used for repeated access to the interior of a piping system. It is not the intent of this Code to impose the requirements of a specific design method on the designer or manufacturer of a quick-opening closure.

Quick-opening closures used for pressure containment under this Code shall have pressure and temperature ratings equal to or in excess of the design requirements of the pipeline system to which they are attached (see paras. 403.1 through 403.6).

Quick-opening closures shall be equipped with safety locking devices in compliance with the ASME BPVC, Section VIII, Division 1, UG-35(b).

Weld end preparation shall be in accordance with para. 434.8.6.

**404.7.2 Closure Fittings.** Closure fittings commonly referred to as "weld caps" shall be designed and manufactured in accordance with ASME B16.9 or MSS SP-75.

**404.7.3 Closure Heads.** Closure heads such as flat, ellipsoidal (other than in para. 404.7.2), spherical, or conical heads are allowed for use under this Code. Such items shall be designed in accordance with the

ASME BPVC, Section VIII, Division 1. The maximum allowable stresses for materials used in these closure heads shall be established under the provisions of para. 403.2.

If welds are used in the construction of these heads, they shall be 100% radiographically inspected in accordance with the provisions of ASME BPVC, Section VIII, Division 1.

Closure heads shall have pressure and temperature ratings equal to or in excess of the requirements of para. 403.2.1. It is not the intent of this Code to necessarily extend the design requirements of ASME BPVC, Section VIII, Division 1, to other components in which closure heads are part of a complete assembly.

**404.7.4 Fabricated Closures.** Orange peel bull plugs are prohibited on systems operating at a hoop stress more than 20% of the specified minimum yield strength of the pipe. Fishtails and flat closures are permitted for NPS 3 and smaller, operating at less than 100 psi (7 bar). Fishtails and flat closures on pipe larger than NPS 3 are prohibited.

**404.7.5 Bolted Blind Flange Closures.** Bolted blind flange closures shall conform to para. 404.4.

## 404.8 Joints

**404.8.1 Butt Welds.** Butt welded joints shall be in accordance with Chapter V.

**404.8.2 Flange Joints.** Flanged joints shall meet the requirements of para. 404.4.

**404.8.3 Threaded Joints.** All external pipe threads on piping components shall be taper pipe threads. They shall be line pipe threads in accordance with API 5B, or NPT threads in accordance with ASME B1.20.1. All internal pipe threads on piping components shall be taper pipe threads, except for sizes NPS 2 and smaller with design gage pressures not exceeding 150 psi (10 bar), in which case straight threads may be used.

**404.8.4 Sleeve, Coupled, and Other Patented Joints.** Steel connectors and swivels complying with API 6H may be used. Cast, malleable, and wrought iron threaded couplings are acceptable subject to the limits of para. 423.2.4. Sleeve, coupled, and other patented joints may be used, provided

(a) a production joint has been subject to proof tests to determine the safety of the joints under simulated service conditions. When vibration, fatigue, cyclic conditions, low temperature, thermal expansion, or other severe conditions are anticipated, the applicable conditions shall be incorporated in the tests.

(b) adequate provisions are made to prevent separation of the joint and to prevent longitudinal or lateral movement beyond the limits provided for in the joining member.

#### 404.9 Supports, Braces, Anchors, and Attachments

**404.9.1 General.** The applicable sections of MSS SP-58 for materials and design of pipe hangers and supports and of MSS SP-69 for their selection and application may be used.

If pipe is designed to operate above 20%  $S_y$ , all attachments welded to the pipe shall be made to a separate cylindrical member that completely encircles the pipe, and this encircling member shall be welded to the pipe by continuous circumferential welds.

**404.9.2 Supports.** Supports shall be designed to support the pipe without causing excessive local stresses in the pipe and without imposing excessive axial or lateral friction forces that might prevent the desired freedom of movement.

**404.9.3 Braces.** Braces and damping devices may occasionally be required to prevent vibration of piping.

**404.9.4 Attachments.** All attachments to the pipe shall be designed to minimize the added stresses in the pipe wall because of the attachment. Nonintegral attachments, such as pipe clamps and ring girders, are preferred where they will fulfill the supporting or anchoring functions.

External and internal attachments to piping shall be designed so they will not cause flattening of the pipe, excessive localized bending stresses, or harmful thermal gradients in the pipe wall.

#### 404.10 Other Pressure-Containing Components

Pressure-containing components that are not covered by the standards listed in [Table 423.1-1](#) or [Table 426.1-1](#) and for which design equations or procedures are not given herein may be used where the design of similarly shaped, proportioned, and sized components has been proven satisfactory by successful performance under comparable service conditions. (Interpolation may be made between similarly shaped proved components with small differences in size or proportion.) In the absence of such service experience, the pressure design shall be based on an analysis consistent with

the general design philosophy embodied in this Code, and substantiated by at least one of the following:

(a) proof tests (as described in ASME BPVC, Section VIII, Division 1, UG-101)

(b) experimental stress analysis (as described in ASME BPVC, Section VIII, Division 2, Annex 5-F)

(c) engineering calculations

#### 404.11 Used Piping Components

(19)

Used piping components such as fittings, elbows, bends, intersections, couplings, reducers, closures, flanges, valves, and equipment may be reused. (Reuse of pipe is covered by [para. 403.10](#)). However, such components and equipment shall be cleaned, examined, and reconditioned, if necessary, to ensure that they meet all requirements for the intended service and are free of defects. See ASME PCC-2, Article 3.5 for more information about flange repair and conversion.

In addition, reuse shall be contingent on identification of the specification under which the item was originally produced. Where the specification cannot be identified, use shall be prohibited.

#### 404.12 Auxiliary and Relief Piping

**404.12.1 Instrument and Other Auxiliary Piping.** All instrument and other auxiliary piping connected to primary piping and that operates at a gage pressure exceeding 15 psi (1 bar) shall be constructed in accordance with the provisions of this Code.

**404.12.2 Relief Piping.** Pressure disposal or relief piping between pressure origin point and relief device shall be in accordance with this Code.

An isolation valve capable of full design flow relief may be installed between the origin point and relief device, provided such valve can be locked or sealed in the open position. Disposal piping from the relief device shall be connected to a proper disposal facility, which may be a flare stack, suitable pit, sump, or tank. This disposal piping shall have no valve between the relief device and the disposal facility unless such valve can be locked or sealed in the open position.

## Chapter III Materials

### 423 MATERIALS — GENERAL REQUIREMENTS

#### 423.1 Acceptable Materials and Specifications

(a) The materials used shall conform to the specifications listed in [Table 423.1-1](#) or shall meet the requirements of this Code for materials not listed. Specific editions of standards incorporated in this Code by reference, and the names and addresses of the sponsoring organizations, are shown in [Mandatory Appendix I](#), since it is not practical to refer to a specific edition of each standard in [Table 423.1-1](#) and throughout the Code text. [Mandatory Appendix I](#) will be revised at intervals, as needed. Materials and components conforming to a specification or standard previously listed in [Table 423.1-1](#), or to a superseded edition of a listed specification or standard, may be used.

(b) Except as otherwise provided for in this Code, materials that do not conform to a listed specification or standard in [Table 423.1-1](#) may be used, provided they conform to a published specification covering chemistry, physical and mechanical properties, method and process of manufacture, heat treatment, and quality control, and otherwise meet the requirements of this Code. Allowable stresses shall be determined in accordance with the applicable allowable stress basis of this Code or a more conservative basis.

#### 423.2 Limitations on Materials

##### 423.2.1 General

(a) The designer shall give consideration to the significance of temperature on the performance of the material. Some of the materials conforming to specifications referenced for use under this Code may not have properties suitable for operation at temperatures below  $-20^{\circ}\text{F}$  ( $-30^{\circ}\text{C}$ ). Users of this Code are cautioned to consider the effects of low temperature and the potential impact on fracture performance at low temperatures.

(b) Selection of material to resist corrosion, erosion, and other deterioration in service is not within the scope of this Code. It is the designer's responsibility to select materials suitable for the fluid or slurry service under the intended operating conditions. An example of a source of information on materials performance in corrosive environments is the Corrosion Data Survey

published by the National Association of Corrosion Engineers.

**423.2.3 Steel.** Steels for pipe are shown in [Table 423.1-1](#) (except as noted in [para. 423.2.5](#)).

Steel pipe designed to be operated at a hoop stress of more than 20%  $S_y$  shall be impact tested in accordance with the procedures of API 5L, PSL 2, or ASTM A333. The test temperature shall be the lower of  $32^{\circ}\text{F}$  ( $0^{\circ}\text{C}$ ) or the lowest expected metal temperature during service, having regard to past recorded temperature data and possible effects of lower air and ground temperatures. The average of the Charpy energy values from each heat shall meet or exceed the following:

(a) For all grades with an  $S_y$  equal to or greater than 42,000 psi (289 MPa), the required minimum average (set of three specimens) absorbed energy for each heat based on full-sized 0.394 in.  $\times$  0.394 in. (10 mm  $\times$  10 mm) specimens shall be 20 lb-ft (27 J) for transverse specimens or 30 lb-ft (41 J) for longitudinal samples.

(b) For all grades with an  $S_y$  less than 42,000 psi (289 MPa), the required minimum average (set of three specimens) absorbed energy for each heat based on full-sized 0.394 in.  $\times$  0.394 in. (10 mm  $\times$  10 mm) specimens shall be 13 lb-ft (18 J).

##### 423.2.4 Cast, Malleable, and Wrought Iron

(a) Cast, malleable, and wrought iron shall not be used for pressure-containing parts except as provided in [para. 404.5](#) and (b) below.

(b) Cast, malleable, and wrought iron are acceptable in pressure vessels and other equipment noted in [para. 400.1.2\(b\)](#), except that pressure-containing parts shall be limited to pressures not exceeding 250 psi (17 bar).

**423.2.5 Materials for Liquid Anhydrous Ammonia Pipeline Systems.** Only steel conforming to specifications listed in [Mandatory Appendix I](#) shall be used for pressure-containing piping components and equipment in liquid anhydrous ammonia pipeline systems. However, internal parts of such piping components and equipment may be made of other materials suitable for the service.

The longitudinal or helical seam weld of electric resistance welded and electric induction welded pipe shall be normalized.



Cold formed fittings shall be normalized after fabrication.

Except for the quantities permitted in steels by individual specifications for steels listed in [Mandatory Appendix I](#), the use of copper, zinc, or alloys of these metals is prohibited for all pressure piping components subject to a liquid anhydrous ammonia environment.

**423.2.6 Materials for Use in Low-Temperature Applications.** Whenever the minimum design temperature (see [para. 401.2.3.7](#)) is below  $-20^{\circ}\text{F}$  ( $-30^{\circ}\text{C}$ ), a fracture control program shall be established. The program shall address parent materials, the parent material seam weld (if present), circumferential butt welds, attachment welds, and any weld heat-affected zone (HAZ). Of primary importance in the fracture control program is the prevention of fracture initiation that can occur at small stress concentrations. As a minimum, the fracture control program shall require Charpy impact energy testing at or below the minimum design temperature, as noted in [para. 423.2.3](#). The specific energy requirement is a function of the strength of the material, its thickness, and the design stress, but shall not be less than the energy values specified in [paras. 423.2.3\(a\)](#) and [423.2.3\(b\)](#).

See [para. 403.7](#) for additional requirements relative to fracture control for pipe.

Provided the manufacturer's fracture toughness testing of reference is performed at or below the pipeline minimum design temperature and meets the requirements of the fracture control plan, additional toughness testing of the material is not required.

Welding procedures for circumferential welds shall be qualified as conforming to the fracture control program by Charpy testing at or below the minimum design temperature.

## **425 MATERIALS APPLIED TO MISCELLANEOUS PARTS** (19)

### **425.3 Gaskets**

Limitations on gasket materials are covered in [para. 404.4.7](#).

### **425.4 Bolting**

Limitations on bolting materials are covered in [para. 404.4.8](#).

(19)

**Table 423.1-1 Material Standards and Specifications**

Designation	Standard or Specification
<b>Pipe</b>	
API 5L	Line Pipe [Note (1)]
ASTM A53	Pipe, Steel, Black & Hot-Dipped, Zinc-Coated Welded & Seamless
ASTM A106	Seamless Carbon Steel Pipe for High-Temperature Service
ASTM A134	Pipe, Steel, Electric-Fusion (Arc)-Welded (Sizes NPS 16 and Over)
ASTM A135	Electric-Resistance-Welded Steel Pipe
ASTM A139	Electric-Fusion (Arc)-Welded Steel Pipe (NPS 4 and Over)
ASTM A312	Seamless and Heavily Cold Worked Welded Austenitic Stainless Steel Pipe
ASTM A333	Seamless and Welded Steel Pipe for Low Temperature Service
ASTM A358	Electric Fusion Welded Austenitic Chromium-Nickel Stainless Steel Pipe for High-Temperature Service and General Application
ASTM A381	Metal-Arc-Welded Steel Pipe for Use With High-Pressure Transmission Systems
ASTM A409	Welded Large Diameter Austenitic Steel Pipe for Corrosive or High-Temperature Service
ASTM A524	Seamless Carbon Steel Pipe for Atmospheric and Lower Temperatures
ASTM A530	General Requirements for Specialized Carbon and Alloy Steel Pipe
ASTM A671	Electric-Fusion-Welded Steel Pipe for Atmospheric and Lower Temperatures
ASTM A672	Electric-Fusion-Welded Steel Pipe for High-Pressure Service at Moderate Temperatures
ASTM A790	Seamless and Welded Ferritic/Austenitic Stainless Steel Pipe
ASTM A928	Ferritic/Austenitic (Duplex) Stainless Steel Pipe Electric Fusion Welded With Addition of Filler Metal
<b>Fittings, Valves, and Flanges</b>	
API 6A	Wellhead and Christmas Tree Equipment
API 6D	Pipeline Valves
API 6DSS	Subsea Pipeline Valve
API 6H	End Closures, Connectors and Swivels
API 600	Steel Gate Valves, Flanged and Buttwelding Ends
API 602	Compact Carbon Steel Gate Valves
API 603	Class 150, Corrosion Resistant Gate Valves
ASME B16.5	Pipe Flanges and Flanged Fittings
ASME B16.34	Valves — Flanged, Threaded, and Welding End
ASME B16.47	Large Diameter Steel Flanges
ASME B16.49	Factory-Made Wrought Steel Buttwelding Induction Bends for Transportation and Distribution Systems
ASTM A105	Carbon Steel Forgings for Piping Components
ASTM A126	Gray Iron Castings for Valves, Flanges, and Pipe Fittings
ASTM A181	Carbon Steel Forgings for General-Purpose Piping
ASTM A182	Forged or Rolled Alloy and Stainless Steel Pipe Flanges, Forged Fittings, and Valves and Parts for High-Temperature Service
ASTM A216	Steel Castings, Carbon, Suitable for Fusion Welding, for High Temperature Service
ASTM A217	Steel Castings, Martensitic Stainless and Alloy, for Pressure Containing Parts, Suitable for High-Temperature Service
ASTM A234	Piping Fittings of Wrought Carbon Steel and Alloy Steel for Moderate and High Temperature Services
ASTM A350	Carbon and Low-Alloy Steel Forgings, Requiring Notch Toughness Testing for Piping Components
ASTM A351	Castings, Austenitic, for Pressure-Containing Parts
ASTM A395	Ferritic Ductile Iron Pressure-Retaining Castings for Use at Elevated Temperatures
ASTM A403	Wrought Austenitic Stainless Steel Piping Fittings
ASTM A420	Piping Fittings of Wrought Carbon Steel and Alloy Steel for Low Temperature Service [Note (2)]
ASTM A487	Steel Castings Suitable for Pressure Service
ASTM A694	Carbon and Alloy Steel Forgings for Pipe Flanges, Fittings, Valves, and Parts for High-Pressure Transmission Service
ASTM A707	Forged, Carbon and Alloy Steel Flanges for Low-Temperature Service
ASTM A815	Wrought Ferritic, Ferritic/Austenitic, and Martensitic Stainless Steel Piping Fittings
MSS SP-44	Steel Pipeline Flanges
MSS SP-55	Quality Standard for Steel Castings for Valves, Flanges and Fittings and Other Piping Components
MSS SP-75	Specification for High Test Wrought Butt Welding Fittings
MSS SP-83	Class 3000 Steel Pipe Unions Socket Welding and Threaded

**Table 423.1-1 Material Standards and Specifications (Cont'd)**

<b>Designation</b>	<b>Standard or Specification</b>
<b>Bolting</b>	
ASTM A193	Alloy-Steel and Stainless Steel Bolting Materials for High-Temperature or High Pressure Service and Other Special Purpose Applications
ASTM A194	Carbon and Alloy Steel Nuts for Bolts for High-Pressure or High-Temperature Service, or Both
ASTM A307	Carbon Steel Bolts and Studs, 60,000 psi Tensile Strength
ASTM A320	Alloy Steel and Stainless Steel Bolting Materials for Low-Temperature Service
ASTM A325	Structural Bolts, Steel, Heat Treated, 120/105 ksi Minimum Tensile Strength
ASTM A354	Quenched and Tempered Alloy Steel Bolts, Studs, and Other Externally Threaded Fasteners
ASTM A449	Hex Cap Screws, Bolts and Studs, Steel, Heat Treated, 120/105/90 ksi Minimum Tensile Strength, General Use
ASTM A490	Structural Bolts, Alloy Steel, Heat Treated, 150 ksi Minimum Tensile Strength
<b>Plates, Bars, and Structural Shapes [Note (3)]</b>	
ASTM A6	General Requirements for Rolled Structural Steel Bars, Plates, Shapes, and Sheet Piling
ASTM A20	General Requirements for Steel Plates for Pressure Vessels
ASTM A29	General Requirements for Steel Bars, Carbon and Alloy, Hot-Wrought
ASTM A36	Carbon Structural Steel
ASTM A225	Pressure Vessel Plates, Alloy Steel, Manganese-Vanadium-Nickel
ASTM A240	Chromium and Chromium-Nickel Stainless Steel Plate, Sheet, and Strip for Pressure Vessels and for General Applications
ASTM A242	High-Strength Low-Alloy Structural Steel
ASTM A283	Low and Intermediate Tensile Strength Carbon Steel Plates
ASTM A285	Pressure Vessel Plates, Carbon Steel, Low- and Intermediate-Tensile Strength
ASTM A441	High-Strength Low-Alloy Structural Manganese Vanadium Steel
ASTM A442	Pressure Vessel Plates, Carbon Steel, Improved Transition Properties
ASTM A505	General Requirements for Steel Sheet and Strip, Alloy, Hot-Rolled and Cold-Rolled
ASTM A506	Alloy and Structural Alloy Steel, Sheet and Strip, Hot-Rolled and Cold-Rolled
ASTM A507	Alloy Drawing and Alloy Steel, Sheet and Strip, Hot-Rolled and Cold-Rolled
ASTM A514	High-Yield-Strength, Quenched and Tempered Alloy Steel Plate, Suitable for Welding
ASTM A515	Pressure Vessel Plates, Carbon Steel, for Intermediate- and Higher-Temperature Service
ASTM A516	Pressure Vessel Plates, Carbon Steel, for Moderate- and Lower-Temperature Service
ASTM A517	Pressure Vessel Plates, Alloy Steel, High-Strength, Quenched and Tempered
ASTM A537	Pressure Vessel Plates, Heat Treated, Carbon-Manganese-Silicon Steel
ASTM A572	High-Strength Low-Alloy Columbium-Vanadium Structural Steels
ASTM A573	Structural Carbon Steel Plates of Improved Toughness
ASTM A575	Steel Bars, Carbon, Merchant Quality, M-Grades
ASTM A576	Steel Bars, Carbon, Hot-Wrought, Special Quality
ASTM A633	Normalized High-Strength Low-Alloy Structural Steel
ASTM A663	Steel Bars, Carbon, Merchant Quality, Mechanical Properties
ASTM A675	Steel Bars, Carbon, Hot-Wrought, Special Quality, Mechanical Properties
ASTM A737	Pressure Vessel Plates, High-Strength, Low-Alloy Steel
ASTM A992	Standard Specification for Structural Steel Shapes
<b>Miscellaneous</b>	
MSS SP-58	Pipe Hangers and Supports — Materials, Design and Manufacture

GENERAL NOTE: Specific editions of standards incorporated in this Code by reference, and the names and addresses of the sponsoring organizations, are shown in [Mandatory Appendix I](#), since it is not practical to refer to a specific edition of each standard in [Table 423.1-1](#) and throughout the Code text. [Mandatory Appendix I](#) will be revised at intervals as needed.

## NOTES:

- (1) Use of PSL 2 pipe is recommended.
- (2) A420 Grade WPL9 is not recommended for anhydrous ammonia due to copper content.
- (3) A36 and A992 are not permitted for pressure-containing parts such as patches, reinforcement plates, or fully welded sleeves.

## Chapter IV

# Dimensional Requirements

### 426 DIMENSIONAL REQUIREMENTS FOR STANDARD AND NONSTANDARD PIPING COMPONENTS

#### 426.1 Standard Piping Components

Dimensional standards for piping components are listed in [Table 426.1-1](#). Also, certain material specifications listed in [Table 423.1-1](#) contain dimensional requirements that are requirements of [section 426](#). Dimensions of piping components shall comply with these standards and specifications unless the provisions of [para. 426.2](#) are met.

#### 426.2 Nonstandard Piping Components

The dimensions for nonstandard piping components shall be such as to provide strength and performance equivalent to standard components or as provided under [section 404](#). Wherever practical, these dimensions shall conform to those of comparable standard components.

#### 426.3 Threads

(19)

The dimensions of all piping connection threads not otherwise covered by a governing component standard or specification shall conform to the requirements of the applicable standards listed in [Table 426.1-1](#) (see [para. 403.2.4](#)).

**Table 426.1-1 Dimensional Standards**

<b>Designation</b>	<b>Standard or Specification</b>
<b>Pipe</b>	
API 5L	Line Pipe ( <i>Combination of previous API 5L, API 5LS, and API 5LX</i> )
ASME B36.10M	Welded and Seamless Wrought Steel Pipe
ASME B36.19M	Stainless Steel Pipe
<b>Fittings, Valves, and Flanges</b>	
API 6A	Wellhead and Christmas Tree Equipment
API 6D	Pipeline Valves
API 600	Steel Gate Valves, Flanged and Buttwelding Ends
API 602	Compact Carbon Steel Gate Valves
API 603	Class 150, Corrosion Resistant Gate Valves
ASME B16.5	Pipe Flanges and Flanged Fittings
ASME B16.9	Factory-Made Wrought Buttwelding Fittings
ASME B16.10	Face-to-Face and End-to-End Dimensions of Valves
ASME B16.11	Forged Fittings, Socket-Welding and Threaded
ASME B16.20	Metallic Gaskets for Pipe Flanges — Ring Joint, Spiral-Wound, and Jacketed
ASME B16.21	Nonmetallic Flat Gaskets for Pipe Flanges
ASME B16.25	Buttwelding Ends
ASME B16.28	Wrought Steel Buttwelding Short Radius Elbows and Returns
ASME B16.34	Valves — Flanged, Threaded, and Welding End
ASME B16.36	Orifice Flanges
ASME B16.47	Large Diameter Steel Flanges
ASME B16.48	Line Blanks
MSS SP-6	Standard Finishes for Contact Faces of Pipe Flanges and Connecting-End Flanges of Valves and Fittings
MSS SP-25	Standard Marking System for Valves, Fittings, Flanges and Unions
MSS SP-44	Steel Pipeline Flanges
MSS SP-61	Pressure Testing of Steel Valves
MSS SP-67	Butterfly Valves
MSS SP-70	Cast Iron Gate Valves, Flanged and Threaded Ends
MSS SP-71	Cast Iron Swing Check Valves, Flanged and Threaded Ends
MSS SP-75	Specification for High Test Wrought Butt Welding Fittings
MSS SP-78	Cast Iron Plug Valves, Flanged and Threaded Ends
MSS SP-83	Steel Pipe Unions Socket Welding and Threaded
MSS SP-95	Swage(d) Nipples and Bull Plugs
MSS SP-97	Integrally Reinforced Forged Branch Outlet Fittings
<b>Miscellaneous</b>	
API 5B	Threading, Gaging, and Thread Inspection of Casing, Tubing, and Line Pipe Threads
ASME B1.1	Unified Inch Screw Threads (UN and UNR Thread Form)
ASME B1.20.1	Pipe Threads, General Purpose (Inch)
ASME B1.20.3	Dryseal Pipe Threads (Inch)
MSS SP-69	Pipe Hangers and Supports — Selection and Application

GENERAL NOTE: Specific editions of standards incorporated in this Code by reference, and the names and addresses of the sponsoring organizations, are shown in [Mandatory Appendix I](#), since it is not practical to refer to a specific edition of each standard in [Table 426.1-1](#) and throughout the Code text. [Mandatory Appendix I](#) will be revised at intervals as needed.

## Chapter V

# Construction, Welding, and Assembly

### 434 CONSTRUCTION

#### 434.1 General

New construction and replacements of existing systems shall be in accordance with the requirements of this Chapter. Where written specifications are required, they shall be in sufficient detail to ensure that the requirements of this Code shall be met. Such specifications shall include specific details on handling of pipe, equipment, materials, welding, and all construction factors that contribute to safety and sound engineering practice. It is not intended herein that all construction items be covered in full detail, since the specification should be all-inclusive. Whether covered specifically or not, all construction and materials shall be in accordance with good engineering, safety, and proven pipeline practice.

#### 434.2 Qualifications

**434.2.1 Construction Personnel.** Construction personnel involved in critical activities shall be qualified by either experience or training. Critical activities include, but are not limited to, the following:

- (a) operation of construction equipment
- (b) directional drilling equipment operators
- (c) individuals responsible for locating underground structures or utilities
- (d) individuals responsible for establishing the location of the pilot string during drilling operations
- (e) blasting operations

- (19) **434.2.2 Inspection.** The operating company shall make provision for suitable inspection of pipeline and related facilities by qualified inspectors to ensure compliance with the construction specifications. Qualification of inspection personnel and the type and extent of inspection shall be in accordance with the requirements of [section 436](#). Repairs required during new construction shall be in accordance with [paras. 434.5, 434.8.7, and 461.1.2](#).

#### 434.3 Right-of-Way

**434.3.1 Location.** Right-of-way should be selected so as to minimize the possibility of hazard from future industrial or urban development or encroachment on the right-of-way.

**434.3.2 Construction Requirements.** Inconvenience to the landowner should be a minimum and safety of the public shall be given prime consideration.

(a) All blasting shall be in accordance with governing regulations and shall be performed by competent and qualified personnel, and performed so as to provide adequate protection to the general public; livestock; wildlife; buildings; telephone, telegraph, and power lines; underground structures; and any other property in the proximity of the blasting.

(b) In grading the right-of-way, every effort shall be made to minimize damage to the land and prevent abnormal drainage and erosive conditions. The land is to be restored to as nearly original condition as is practical.

(c) In constructing pipeline crossings of railroads, highways, streams, lakes, rivers, etc., safety precautions such as signs, lights, guardrails, etc., shall be maintained in the interest of public safety. The crossings shall comply with the applicable rules, regulations, and restrictions of regulatory bodies having jurisdiction.

**434.3.3 Survey and Staking or Marking.** The route shall be surveyed and staked, and such staking or marking should be maintained during construction, except route of pipeline offshore shall be surveyed and the pipeline shall be properly located within the right-of-way by maintaining survey route markers or by surveying during construction.

#### 434.4 Handling, Hauling, Stringing, and Storing (19)

Care shall be exercised in the handling or storing of pipe, casing, coating materials, valves, fittings, and other materials to prevent damage. Transportation by truck or other road vehicles, railcars, and marine vessels shall be performed in such a manner as to avoid damage to the pipe and any pre-applied coatings. Transportation of line pipe shall conform to the requirements of API RP 5LT, API RP 5LW, and API RP 5L1, as applicable. In the event pipe is yard coated or mill coated, adequate precautions shall be taken to prevent damage to the coating when hauling, lifting, and placing on the right-of-way. Pipe shall not be allowed to drop and strike objects that will distort, dent, flatten, gouge, or notch the pipe or damage the coating, but shall be lifted or lowered by suitable and safe equipment.



### 434.5 Damage to Fabricated Items and Pipe

(a) Fabricated items such as scraper traps, manifolds, volume chambers, etc., shall be inspected before assembly into the mainline or manifolding and defects shall be repaired in accordance with provisions of the standard or specification applicable to their manufacture.

(b) Pipe shall be inspected before coating and before assembly into the mainline or manifolding. Distortion, buckling, denting, flattening, gouging, grooves, or notches, and all defects of this nature shall be prevented, repaired, or eliminated as specified herein.

(1) Injurious gouges, grooves, or notches shall be removed. These defects may be repaired by the use of welding procedures prescribed in API 5L or removed by grinding, provided the resulting wall thickness is not less than that permitted by the material specification.

(2) When conditions outlined in (1) cannot be met, the damaged portion shall be removed as a cylinder. Insert patching is not permitted. Weld-on patching, other than complete encirclement, is not permitted in pipelines intended to operate at a hoop stress of more than 20% of the specified minimum yield strength of the pipe.

(3) Notches or laminations on pipe ends shall not be repaired. The damaged end shall be removed as a cylinder and the pipe end properly rebeveled.

(4) Distorted or flattened lengths shall be discarded.

(5) A dent containing a stress concentrator, such as a scratch, gouge, groove, or arc burn, shall be removed by cutting out the damaged portion of the pipe as a cylinder.

(6) All dents that affect the curvature of the pipe at the seam or at any girth weld shall be removed as in (5). All dents that exceed a maximum depth of  $\frac{1}{4}$  in. (6.4 mm) in pipe NPS 12 and smaller, or 2% of the nominal pipe diameter in sizes greater than NPS 12, shall not be permitted in pipelines intended to operate at a hoop stress of more than 20% of the specified minimum yield strength of the pipe. Insert patching, overlay, or pounding out of dents shall not be permitted in pipelines intended to operate at a hoop stress of more than 20% of the specified minimum yield strength of the pipe.

(7) Buckled pipe shall be replaced as a cylinder.

### 434.6 Ditching

(a) Depth of ditch shall be appropriate for the route location, surface use of the land, terrain features, and loads imposed by roadways and railroads. All buried pipelines shall be installed below the normal level of cultivation and with a minimum cover not less than that shown in Table 434.6-1. Where the cover provisions of Table 434.6-1 cannot be met, pipe may be installed with less cover if additional protection is provided to withstand anticipated external loads and to minimize damage to the pipe by external forces.

(b) Width and grade of ditch shall provide for lowering of the pipe into the ditch to minimize damage to the coating and to facilitate fitting the pipe to the ditch.

(c) Location of underground structures intersecting the ditch route shall be determined in advance of construction activities to prevent damage to such structures.

(d) Ditching operations shall follow good pipeline practice and consideration of public safety. API RP 1102 will provide additional guidance.

### 434.7 Bends, Miters, and Elbows

Changes in direction, including sags or overbends required to conform to the contour of the ditch, may be made by bending the pipe or using miters, factory-made bends, or elbows. (See limitations in para. 404.2.)

#### 434.7.1 Bends Made From Pipe

(19)

(a) Bends shall be made from pipe having wall thicknesses determined in accordance with para. 404.2.1. When hot bends are made in pipe that has been cold worked in order to meet the specified minimum yield strength, wall thicknesses shall be determined by using the lower stress values in accordance with para. 403.11.

(b) Bends shall be made in such a manner as to preserve the cross-sectional shape of the pipe, and shall be free from buckling, cracks, or other evidence of mechanical damage. The pipe diameter shall not be reduced at any point by more than  $2\frac{1}{2}\%$  of the nominal diameter, and the completed bend shall pass the specified sizing pig.

(c) The minimum radius of field cold bends shall be as specified in para. 404.2.2.

(d) Tangents approximately 6 ft (2 m) in length are preferred on both ends of cold bends.

(e) When bends are made in longitudinally welded pipe, the longitudinal weld should be located on or near the neutral axis of the bend.

#### 434.7.2 Mitered Bends

(a) Mitered bends are permitted subject to limitations in para. 404.2.4.

(b) Care shall be taken in making mitered joints to provide proper spacing and alignment and full-penetration welds.

#### 434.7.3 Factory-Made Bends and Elbows

(a) Factory-made wrought steel welding bends and factory-made elbows may be used subject to limitations in para. 404.2.5, and transverse segments cut therefrom may be used for changes in direction, provided the arc distance measured along the crotch is at least 2 in. (50 mm) on pipe size NPS 4 and larger.

(b) If the internal diameter of such fittings differs by more than  $\frac{3}{16}$  in. (5 mm) from that of the pipe, the fitting shall be treated as indicated in Figure 434.8.6-2 or use a transition nipple not less than one-half pipe

**Table 434.6-1 Minimum Cover for Buried Pipelines**

Location	For Normal Excavation, in. (m)	For Rock Excavation Requiring Blasting or Removal by Equivalent Means, in. (m)
Cultivated, agricultural areas where plowing or subsurface ripping is common	48 (1.2) [Note (1)]	N/A
Industrial, commercial, and residential areas	48 (1.2)	30 (0.75)
River and stream crossings	48 (1.2)	18 (0.45)
Drainage ditches at roadways and railroads	48 (1.2)	30 (0.75)
All other areas	36 (0.9)	18 (0.45)

NOTE: (1) Pipelines may require deeper burial to avoid damage from deep plowing; the designer is cautioned to account for this possibility.

diameter in length with acceptable joint designs as illustrated in Figure 434.8.6-2.

## 434.8 Welding

### 434.8.1 General

(a) *Scope.* Welding herein applies to the arc and gas welding of pipe in both wrought and cast steel materials as applied in pipelines and connections to apparatus or equipment. This includes butt joints in the installation of pipe, valves, flanges, fittings, and other equipment, and fillet welded joints in pipe branches, slip-on flanges, etc. It does not apply to the welding of longitudinal or helical seam joints in the manufacture of pipe, fittings, and valves, or to pressure vessels or assemblies manufactured in accordance with the ASME BPVC, Section VIII, Division 1 or Division 2.

(b) *Welding Terms.* Definitions pertaining to welding as used in this Code conform to the standard definitions established by the American Welding Society and contained in AWS A3.0; ASME BPVC, Section IX; and API 1104.

(c) *Safe Practices in Cutting and Welding.* Prior to cutting and welding in areas in which the possible leakage or presence of vapor or flammable liquid constitutes a hazard of fire or explosion, a thorough check shall be made to determine the presence of a combustible gas mixture or flammable liquid. Cutting and welding shall begin only when safe conditions are indicated.

### (19) 434.8.2 Welding Processes and Filler Metal

(a) Welding shall be performed by a process or a combination of processes that produces welds that meet the procedure qualification requirements of this Code. Welds may be produced by positioning welding, roll welding, or a combination of position and roll welding.

(b) Unless otherwise specified by the operating company, welding electrodes and consumables shall comply with the following:

(1) Filler metal and consumables shall be selected so that the strength of the completed weldment will equal or exceed the specified minimum tensile strength of the materials being joined.

(2) If base metals of different tensile strengths are to be joined, the nominal tensile strength of the weld metal shall equal or exceed the tensile strength of the weaker of the two.

(3) When filler metals of different strengths are used in a single weld, the proportions shall be such that the completed weldment equals the specified minimum tensile strength of the base metal.

(4) For alloy steels, the nominal chemical analysis of the weld metal shall be the same as the nominal chemical analysis of the base metal. If base metals of different chemical analysis are being joined, the weld metal shall be the same as either base metal, or of intermediate composition. Where austenitic steels are joined to ferritic steels, the weld metal shall have an austenitic structure.

### 434.8.3 Welder and Welding Procedure Qualifications

(a) Welder and welding procedure qualifications for cross-country pipelines shall be performed in accordance with API 1104. Welder and welding procedure qualifications for alloy steel and for shop-fabricated piping assemblies, and welding at stations and terminals shall be performed in accordance with API 1104 or ASME BPVC, Section IX.

(b) Prior to any welding covered by this Code, a welding procedure specification shall be established and qualified by testing to demonstrate that welds having suitable mechanical properties and soundness can be produced. Welding procedure specifications shall be qualified as required by API 1104 or ASME BPVC, Section IX, whichever is appropriate for the locations, materials, and type of welding to be performed, except as modified by the following:

(1) *Standard Welding Procedures.* Standard Welding Procedure Specifications (SWPSs) published by the American Welding Society and listed in Mandatory Appendix E of ASME BPVC, Section IX are permitted for code construction within the limitations established by ASME BPVC, Section IX, Article V. Either the employer shall demonstrate his ability to follow SWPSs as required by ASME BPVC, Section IX or he shall qualify one welder or welding operator following each SWPS.



(2) *Procedure Qualification by Others.* In order to avoid duplication of effort, and subject to the approval of the owner, WPSs qualified by a technically competent group or agency may be used, provided the following are met:

(-a) The WPSs meet the requirements of ASME BPVC, Section IX or API 1104 and any additional qualification requirements of this Code.

(-b) The employer has qualified at least one welder or welding operator following each WPS.

(-c) The employer's business name shall be shown on each WPS and on each qualification record. In addition, qualification records shall be signed and dated by the employer, thereby accepting responsibility for the qualifications performed by others.

The welding procedure specification shall be adhered to during welding performed under this Code.

(c) The welding procedure specifications shall at a minimum include the information required by API 1104 or ASME BPVC, Section IX. When materials, welding consumables, mechanical restraint, service conditions, and/or weather conditions make more details necessary to produce a sound weld, such as preheat, interpass temperature, and postweld heat treatment, such details shall be provided. When joining materials with notch-toughness requirements, particularly for low-temperature service, consideration shall be given to weld metal and heat-affected zone toughness requirements in the welding procedure specification. See ASME B31T for more information about weld procedure qualification requirements for piping that may be subject to brittle failure due to low-temperature service conditions. When applicable, the test method, temperature, specimen, and acceptance criteria shall be specified in the welding procedure specification.

(d) API 1104 and ASME BPVC, Section IX contain sections entitled "Essential Variables" applicable to welding procedure specifications, procedure qualification records, and welder qualifications. The classification of base materials and weld filler materials into groups does not imply that other materials within a particular group may be indiscriminately substituted for the base material or weld filler material used for the qualification test. Welding procedure qualification tests shall be conducted with the highest strength base metal to be welded in the essential variable groups identified in the procedure specification.

(e) Prior to any welding covered by this Code, each welder or welding operator shall be qualified as required by API 1104 or ASME BPVC, Section IX, whichever is appropriate for the locations, materials, and type of welding to be performed.

In order to avoid duplication of effort and subject to the approval of the owner, an employer may accept the performance qualification of a welder or welding operator made by a previous employer. This acceptance is limited to

performance qualifications that were made on pipe or tube test coupons. The new employer shall have the WPS that was followed during qualification or an equivalent WPS that is within the limits of the essential variables. An employer accepting such qualification tests shall obtain a copy of the performance qualification test record from the previous employer. The record shall show the name of the employer by whom the welders or welding operator was qualified and the date of that qualification. A record showing use of the process or processes from the date of the welder's qualification shall be available. The new employer's business name shall be shown on the qualification record, and it shall be signed and dated by the employer, thereby accepting responsibility for the qualifications performed by others.

Welder requalification tests are required if there is some specific reason to question a welder's ability or if the welder is not engaged in a given process of welding for a period of 6 months or more.

(f) The operating company shall be responsible for qualifications of procedures and welders. The preparation of welding procedure specifications and/or performance of welding qualification tests may be delegated to others; however, each company that performs welding activities is responsible for the welding activities performed by its employees and contractors.

(g) *Qualification Records.* The welding procedure followed during the qualifying tests shall be recorded in detail. Records of the tests that establish the qualification of a welding procedure specification shall be retained as long as that procedure is in use. A record of the welders qualified, showing the date and results of the tests, shall be retained during the construction involved and for 6 months thereafter. These records shall be available to the owner or the owner's agent and the inspector at the location where the welding is being done.

**434.8.4 Welding Standards.** All the welding done under this Code shall be performed under a specification that embodies the minimum requirements of this Code and shall encompass the requirements of API 1104 except as provided in [paras. 434.8.3\(a\)](#) and [434.8.3\(b\)](#).

#### **434.8.5 Required Inspection and Acceptance Criteria**

##### *(a) Required Inspection*

(1) The quality of welding shall be checked by visual inspection and supplemental nondestructive methods or by removing completed welds as selected and designated by the inspector for destructive testing.

(2) All welds shall be visually inspected.

(3) When the pipeline is to be operated at a hoop stress of more than 20% of the specified minimum yield strength of the pipe, the welds shall be inspected. A minimum of 10% of the girth welds and 10% of the other welds completed each day shall be randomly selected by the operating company and nondestructively inspected. The inspection of girth welds shall be by

radiographic or other accepted volumetric methods. Nonvolumetric methods, such as dye penetrant or magnetic particle, may be used for other welds. Each weld inspected shall be inspected completely with the selected method. In the following locations or conditions, all welds in the pipe shall be completely inspected; however, if some of the welds are inaccessible, a minimum of 90% of the welds are to be inspected:

(-a) within populated areas such as residential subdivisions, shopping centers, and designated commercial and industrial areas

(-b) river, lake, and stream crossings within the area subject to frequent inundation; and river, lake, and stream crossings on bridges

(-c) railroad or public highway rights-of-way, including tunnels, bridges, and overhead railroad and road crossings

(-d) offshore and inland coastal waters

(-e) old girth welds in used pipe

(-f) tie-in girth welds not hydrostatically tested in accordance with [para. 437.4.1](#)

(b) *Inspection Methods and Acceptance Standards*

(1) Nondestructive inspection shall consist of visual inspection and radiographic examination or other acceptable nondestructive methods, and shall be in accordance with API 1104. The methods used shall be capable of producing indications of potential defects that can be accurately interpreted and evaluated. Welds shall meet the acceptance standards for discontinuities contained in API 1104, or the alternate acceptance standards for girth welds in Mandatory Appendix I of API 1104.

(2) Completed welds that have been removed for destructive examination shall meet the requirements of API 1104 for Welder Qualification by Destructive Testing. Trepanning methods of testing shall not be used.

#### 434.8.6 Types of Welds, Joint Designs, and Transition Nipples

(a) *Butt Welds.* Butt welded joints may be of the single vee, double vee, or other suitable type of groove. Joint designs shown in [Figure 434.8.6-1](#) or applicable combinations of these joint design details are recommended for ends of equal thickness. The transition between ends of unequal thickness may be accomplished by taper or welding as shown in [Figure 434.8.6-2](#), or by means of a prefabricated transition nipple not less than one-half pipe diameter in length with acceptable joint designs as illustrated in [Figure 434.8.6-2](#).

(b) *Fillet Welds.* Fillet welds may be concave to slightly convex. The size of a fillet weld is stated as a leg length of the largest inscribed right isosceles triangle as shown in [Figure 434.8.6-3](#) covering recommended attachment details of flanges.

(c) *Tack Welds.* Tack welding shall be done by qualified welders, the same as all other welds.

#### 434.8.7 Removal or Repair of Defects

(a) *Arc Burns.* Arc burns can cause serious stress concentrations in pipelines and shall be prevented, removed, or repaired. The metallurgical notch caused by arc burns shall be removed by grinding, provided the grinding does not reduce the remaining wall thickness to less than the minimum permitted by the material specifications. Complete removal of the metallurgical notch created by an arc burn can be determined as follows. After visible evidence of the arc burn has been removed by grinding, swab the ground area with a minimum 10% solution of ammonium persulfate or a 5% solution of nital. A darkened spot is evidence of a metallurgical notch and indicates that additional grinding is necessary. If the resulting wall thickness after grinding is less than that permitted by the material specification, the portion of pipe containing the arc burn shall be removed or repaired in accordance with [para. 451.6](#). Insert patching is prohibited.

(b) *Weld Defects.* Authorization for repair of welds, removal and repair of weld defects, and testing of weld repairs shall be in accordance with API 1104.

(c) *Pipe Defects.* Laminations, split ends, or other defects in the pipe shall be repaired or removed in accordance with [para. 434.5\(b\)](#).

#### 434.8.8 Preheating and Interpass Temperature

(a) The welding procedure specification shall specify the minimum preheat temperature. When the welding procedure specification specifies preheating above ambient temperatures, the method of heating shall be specified. For heat treated and other high strength materials and impact tested materials, control of interpass temperatures may be necessary. The operating company shall determine when interpass temperature limits are necessary, and, when required, the interpass temperatures shall be provided in the welding procedure specification.

(b) When welding dissimilar materials having different preheating requirements, the material requiring the higher preheat shall govern.

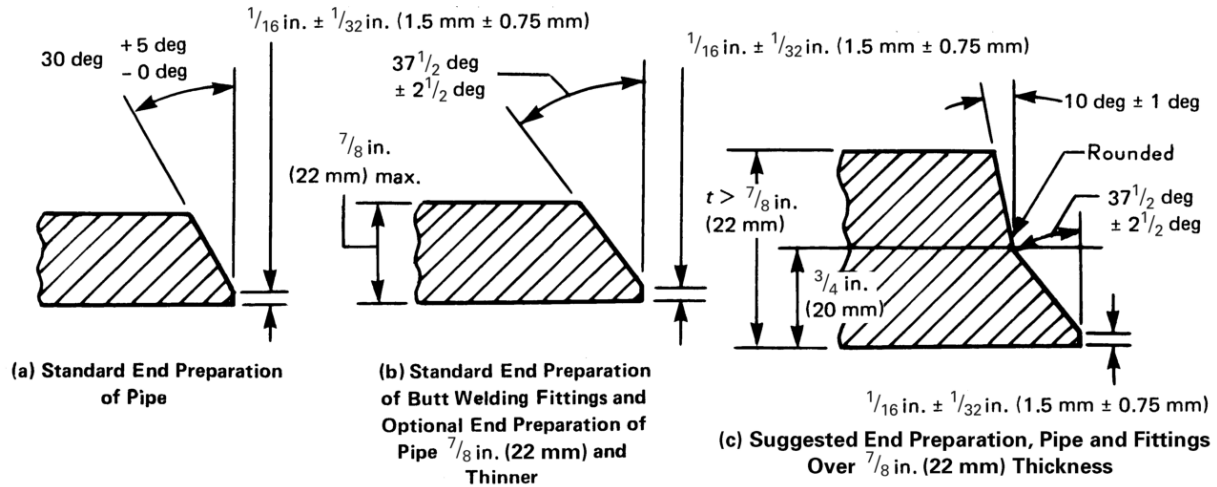
(c) The preheating temperature shall be checked by the use of temperature-indicating crayons, thermocouple pyrometers, or other suitable method to ensure that the required temperature is attained prior to and maintained during the welding operation.

#### 434.8.9 Stress Relieving

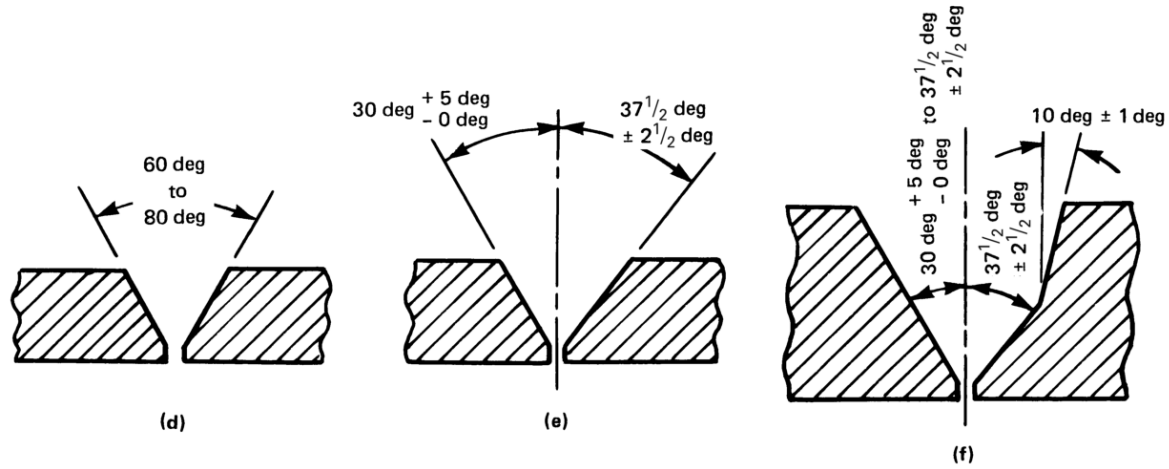
(a) Welds shall be stress relieved when the effective weld throat (see [Figure 434.8.6-2](#)) exceeds  $1\frac{1}{4}$  in. (32 mm), unless it can be demonstrated by welding procedure qualification tests, using materials of the same specification, type, and grade with an effective weld throat that is equal to or greater than the production weld, that stress relieving is not necessary.

(19)

**Figure 434.8.6-1 Acceptable Butt Welded Joint Design for Equal Wall Thicknesses**



**Standard End Preparations**



**Acceptable Combinations of Pipe End Preparations**

Welds in carbon steels having an effective weld throat larger than  $1\frac{1}{4}$  in. (32 mm) and not larger than  $1\frac{1}{2}$  in. (38 mm) may be exempted from stress relieving if a minimum preheating temperature of 200°F (93°C) is used. The welding procedure specification shall specify when stress relieving and/or heat treatment is required due to composition, thickness, welding process, restraint of the weld joint, or service conditions. When required, the welding procedure qualification test shall include stress relieving and/or heat treatment of the completed test joint. The postweld stress-relieving and heat treatment requirements in ASME B31.3 or ASME BPVC, Section VIII, Division 1 or Division 2 may be used as a guide for minimum stress-relieving and heat-treating requirements.

The thickness to be used to determine the stress-relieving requirements of branch connections or slip-on flanges shall be the thickness of the pipe or header.

(b) In welds between dissimilar materials, if either material requires stress relieving, the joint shall require stress relieving.

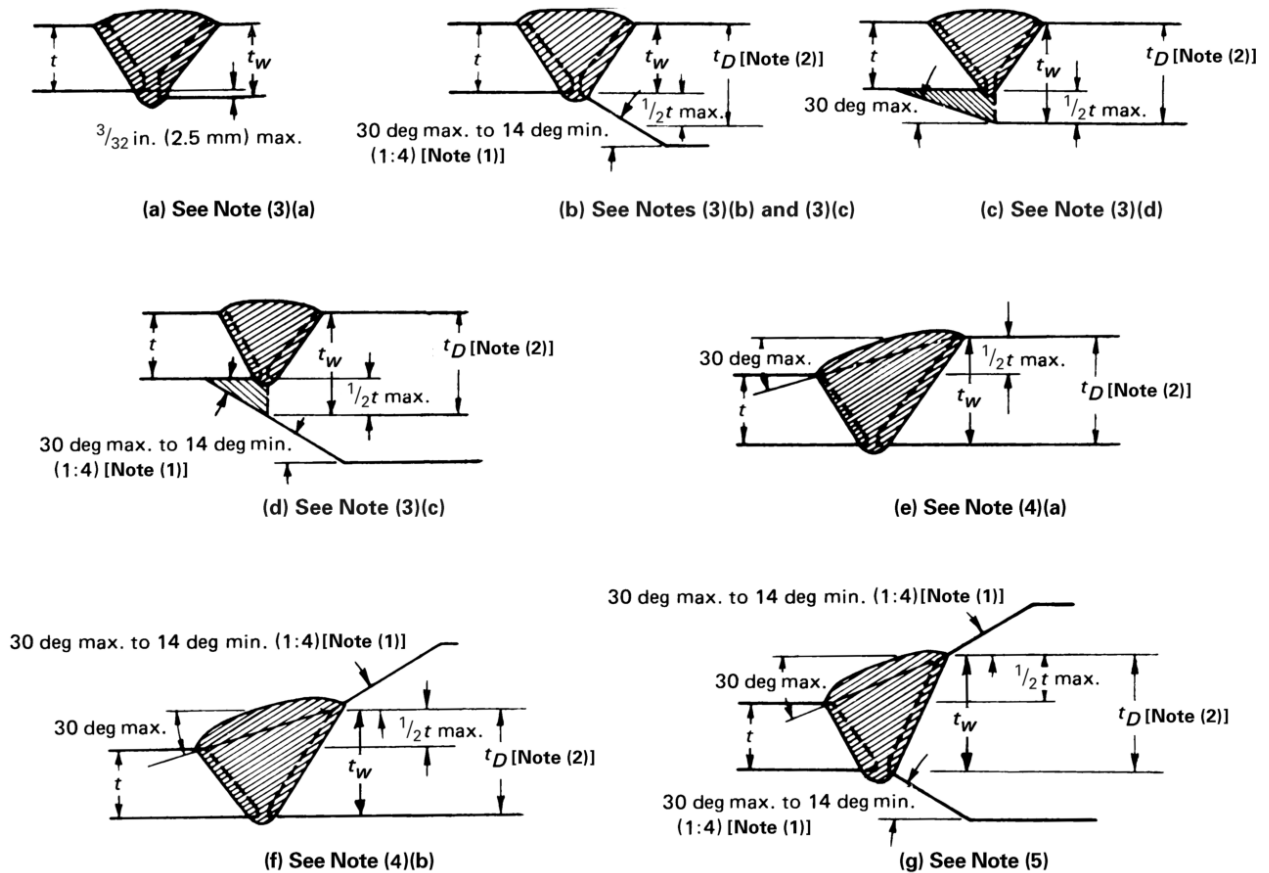
**434.9 Tie-In**

Gaps left in the continuous line construction at such points as river, canal, highway, or railroad crossings require special consideration for alignment and welding. Sufficient equipment shall be available and care exercised not to force or strain the pipe to proper alignment.

**434.10 Installation of Pipe in the Ditch**

It is very important that stresses induced into the pipeline by construction be minimized. The pipe shall fit the ditch without the use of external force to hold it in place until the backfill is completed. When the pipe is lowered

Figure 434.8.6-2 Acceptable Butt Welded Joint Design for Unequal Wall Thicknesses



GENERAL NOTES:

- (a) The illustrations in Figure 434.8.6-2 illustrate acceptable preparations for joining pipe ends having unequal wall thicknesses and/or materials of unequal specified minimum yield strength by butt welding.
- (b) The wall thickness of the pipes to be joined, beyond the joint design area, shall comply with the design requirements of this Code.
- (c) When the specified minimum yield strengths of the pipes to be joined are unequal, the deposited weld metal shall have mechanical properties at least equal to those of the pipe having the higher strength.
- (d) The transition between ends of unequal thickness may be accomplished by taper or welding as illustrated or by means of a prefabricated transition nipple not less than one-half pipe diameter in length.
- (e) Sharp notches or grooves at the edge of the weld where it joins a slanted surface shall be avoided.
- (f) For joining pipes of unequal wall thicknesses and equal specified minimum yield strengths, the rules given herein apply, except there is no minimum angle limit to the taper.
- (g) The effective weld throat,  $t_w$ , shall be used for determining postweld heat treatment requirements.

NOTES:

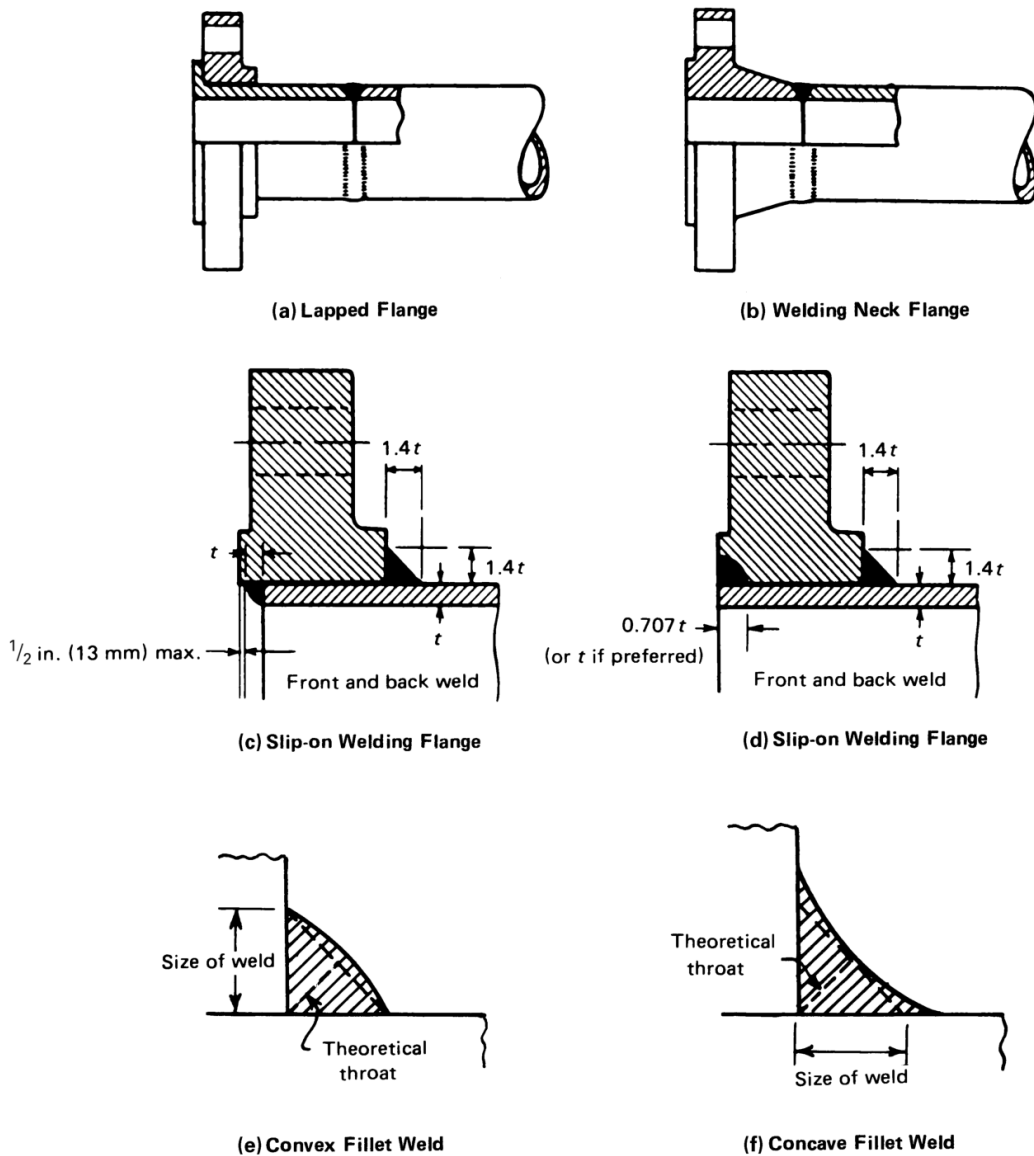
- (1) No minimum when materials joined have equal yield strength [see General Note (f)].
- (2) Maximum thickness,  $t_D$ , for design purposes shall not be greater than  $1.5t$ .
- (3) *Internal Diameters Unequal*
  - (a) If the nominal wall thicknesses of the adjoining pipe ends do not vary more than  $\frac{3}{32}$  in. (2.5 mm), no special treatment is necessary, provided full penetration and bond are accomplished in welding. See illustration (a).
  - (b) Where the nominal internal offset is more than  $\frac{3}{32}$  in. (2.5 mm) and there is no access to the inside of the pipe for welding, the transition shall be made by a taper cut on the inside end of the thicker pipe. See illustration (b). The taper angle shall not be steeper than 30 deg nor less than 14 deg.
  - (c) Where the nominal internal offset is more than one-half the wall thickness of the thinner pipe, and there is access to the inside of the pipe for welding, the transition may be made with a taper cut on the inside end of the thicker pipe [see illustration (b)], or by a combination taper weld to one-half the wall thickness of the thinner pipe and a taper cut from that point [see illustration (d)].
  - (d) For hoop stresses of more than 20% of the specified minimum yield strength of the pipe, where the nominal internal offset is more than  $\frac{3}{32}$  in. (2.5 mm) but does not exceed one-half the wall thickness of the thinner pipe, and there is access to the inside of the pipe for welding, the transition may be made with a tapered weld. See illustration (c). The land on the thicker pipe shall be equal to the offset plus the land on abutting pipe.
- (4) *External Diameters Unequal*
  - (a) Where the external offset does not exceed one-half the wall thickness of the thinner pipe, the transition may be made by welding [see illustration (e)], provided the angle of rise of the weld surface does not exceed 30 deg and both bevel edges are properly fused.

**Figure 434.8.6-2 Acceptable Butt Welded Joint Design for Unequal Wall Thicknesses (Cont'd)**

NOTES (Cont'd)

- (b) Where there is an external offset exceeding one-half the wall thickness of the thinner pipe, that portion of the offset over one-half the wall thickness of the thinner pipe shall be tapered. See illustration (f).
- (5) *Internal and External Diameters Unequal.* Where there is both an internal and an external offset, the joint design shall be a combination of illustrations (a) through (f). See illustration (g). Particular attention shall be paid to proper alignment under these conditions.

**Figure 434.8.6-3 Recommended Attachment Details of Flanges**





into the ditch, care shall be exercised so as not to impose undue stress in the pipe. Slack loops may be used where laying conditions render their use advisable.

#### 434.11 Backfilling

Backfilling shall be performed in a manner to provide firm support of the pipe. When there are large rocks in the backfill material, care shall be exercised to prevent damage to the pipe and coating by such means as the use of a rock shield material, or by making the initial fill with a rock-free material sufficient to prevent rock damage. Where the ditch is flooded, care shall be exercised so that the pipe is not floated from the bottom of the ditch prior to backfill completion.

#### 434.12 Restoration of Right-of-Way and Cleanup

These operations shall follow good construction practices and considerations of private and public safety.

#### 434.13 Special Crossings

Water, railroad, and highway crossings require specific considerations not readily covered in a general statement, since all involve variations in basic design. The pipeline company shall obtain required permits for such crossings. The design shall employ sound engineering and good pipeline practice with minimum hazard to the facility and due consideration of public safety. Construction shall be so organized as to result in minimal interference with traffic or the activities of adjacent property owners. Adequate efforts shall be made to determine the location of buried pipelines, utility lines, and other underground structures along and crossing the proposed right-of-way. The owners of any affected structures shall be given adequate prior notice of the proposed construction so that the owner may make operational preparations and provide a representative at the crossing.

**434.13.1 Water Crossings.** Crossings of rivers, streams, lakes, and inland bodies of water are individual problems, and the designer shall investigate composition of bottom, variation in banks, velocity of water, scouring, and special seasonal problems. The designer shall determine whether the crossing is to be underwater, overhead on a suspension bridge, or supported on an adjacent bridge. Continuity of operation and the safety of the general public shall be the controlling factors both in design and in construction. Where required, detailed plans and specifications shall be prepared, taking into account these and any special considerations or limitations imposed by the regulatory body involved.

Plans and specifications for underwater construction shall describe the position of the line, showing relationship of the pipeline to the natural bottom and the depth below mean low water level when applicable. To meet the conditions set out in [para. 434.13.1](#), heavier wall pipe may be specified. Approach and position of the line in the banks

is important, as is the position of the line across the bottom. Special consideration shall be given to depth of cover and other means of protecting the pipeline in the surf zone. Special consideration shall be given to protective coating and the use of concrete jacketing or the application of river weights. Complete inspection shall be provided. Precautions shall be taken during construction to limit stress below the level that would produce buckling or collapse due to out-of-roundness of the completed pipeline.

**434.13.2 Overhead Structures.** Overhead structures used to suspend pipelines shall be designed and constructed on the basis of sound engineering and within the restrictions or regulations of the governing body having jurisdiction. Detailed plans and specifications shall be prepared where required, and adequate inspection shall be provided to ensure complete adherence thereto.

**434.13.3 Bridge Attachments.** Special requirements are involved in this type of crossing. The use of higher strength lightweight steel pipe, proper design and installation of hangers, and special protection to prevent damage by the elements or bridge and approach traffic shall be considered. Any agreed-upon restrictions or precautions shall be contained in the detailed specifications. Inspectors shall assure themselves that these requirements are met.

#### 434.13.4 Railroad and Highway Crossings

(a) The safety of the general public and the prevention of damage to the pipeline by reason of its location are primary considerations. The great variety of such crossings precludes standard design. The construction specifications shall cover the procedure for such crossings, based on the requirements of the specific location.

(b) Installation of uncased carrier pipe is preferred. Installation of carrier pipe, or casing if used, shall be in accordance with [para. 402.8](#). As specified in [para. 461.1.7](#), if casing is used, coated carrier pipe shall be independently supported outside each end of the casing and insulated from the casing throughout the cased section, and casing ends shall be sealed using a durable, electrically nonconductive material.

**434.13.5 Directionally Drilled Crossings.** Written (19) plans shall be developed for all directionally drilled crossings or for when directional drilling is selected as a pipe lay method. Plans will include the following:

(a) crossing plan and profile drawings showing all pipelines, utilities, cables, and structures that cross the drill path, are parallel to and within 100 ft (30 m) of the drill path, and that are within 100 ft (30 m) of the drilling operation, including mud pits and bore pits.

(b) damage prevention plan to reduce the likelihood of damage to adjacent underground facilities, including pipelines, utilities, cables, and other subsurface structures. The

plan shall consider the accuracy of the method to be employed in locating existing structures and in tracking the position of the pilot string during drilling. Consideration should be given to having an auxiliary location system to include manual excavation to ensure that the drilling bit or reamer is following the projected path and does not encroach upon crossing or parallel lines. The damage prevention plan should provide specific instructions regarding the notification of affected parties, including the participation in one-call systems where applicable.

(c) written safety plan to include contingency plans in the event the drilling string impacts subsurface facilities. The safety plan should identify facilities and resources to be utilized in the event of an emergency or any personnel injuries. The safety plan shall be reviewed on-site with all construction personnel prior to the commencement of drilling operations.

(d) plan for containment and disposal of drilling fluids, if used.

(e) hydrostatic test plan that should consider pretesting of the fabricated string(s) prior to installing the crossing.

The following publications provide guidance on design of directionally drilled crossings:

- American Gas Association PR-227-9424 "Installation of Pipelines by Horizontal Directional Drilling, An Engineering Design Guide"
- American Society of Civil Engineers, Practice No. 89 — "Pipeline Crossings Handbook"
- Directional Crossing Contractors Association publications "Guidelines for a Successful Directional Crossing Bid Package," "Directional Crossing Survey Standards," and "Guidelines for Successful Mid-Sized Directional Drilling Projects"

#### 434.14 Inland Coastal Water Construction

Plans and specifications shall describe alignment of the pipeline, depth below mean water level, and depth below bottom if ditched. Special consideration shall be given to depth of cover and other means of protecting the pipeline in the surf zone. Consideration shall be given to use of weight coating(s), anchors, or other means of maintaining position of the pipe under anticipated conditions of buoyance and water motion. Complete construction inspection shall be provided. Precautions shall be taken during construction to limit stress below the level that would produce buckling or collapse due to out-of-roundness of the completed pipeline.

#### 434.15 Block and Isolating Valves

##### 434.15.1 General

(a) Block and isolating valves shall be installed for limiting hazard and damage from accidental discharge and for facilitating maintenance of the piping system.

(b) Valves shall be at accessible locations, protected from damage or tampering, and suitably supported to prevent differential settlement or movement of the attached piping. Where an operating device to open or close the valve is provided, it shall be protected and accessible only to authorized persons.

(c) Submerged valves on pipelines shall be marked or spotted by survey techniques to facilitate quick location when operation is required.

#### 434.15.2 Mainline Valves

(19)

(a) Mainline block valves shall be installed on the upstream side of major river crossings and public water supply reservoirs. Either a block or check valve shall be installed on the downstream side of major river crossings and public water supply reservoirs.

(b) A mainline block valve shall be installed at mainline pump stations, and a block or check valve (where applicable to minimize pipeline backflow) shall be installed at other locations appropriate for the terrain features. In industrial, commercial, and residential areas where construction activities pose a particular risk of external damage to the pipeline, provisions shall be made for the appropriate spacing and location of mainline valves consistent with the type of liquids and slurries being transported.

(c) A remotely operated mainline block valve shall be provided at remotely controlled pipeline facilities to isolate segments of the pipeline.

(d) On piping systems transporting LPG or liquid anhydrous ammonia, check valves shall be installed where applicable with each block valve to provide automatic blockage of reverse flow in the piping system.

(e) In order to facilitate operational control, limit the duration of an outage, and expedite repairs, mainline block valves shall be installed at 7.5 mile (12 km) maximum spacing on piping systems transporting LPG or liquid anhydrous ammonia in industrial, commercial, and residential areas.

(f) Mainline block valve locations shall be confirmed by an analysis of the potential hazards and impacts resulting from an inadvertent release of product.

#### 434.15.3 Pump Station, Tank Farm, Slurry Holding Pond, and Terminal Valves

(a) Valves shall be installed on the suction and discharge of pump stations whereby the pump station can be isolated from the pipeline.

(b) Valves shall be installed on lines entering or leaving tank farms or terminals at convenient locations whereby the tank farm, slurry holding pond, or terminal may be isolated from other facilities such as the pipeline, manifolds, or pump stations.

### 434.16 Connections to Main Lines

Where connections to the main line such as branch lines, jump-overs, relief valves, air vents, etc., are made to the main line, they shall be made in accordance with [para. 404.3.1](#). When such connections or additions are made to coated lines, all damaged coating shall be removed and replaced with new coating material in accordance with [para. 461.1.2](#). This protective coating should include the attachments.

### 434.17 Scraper Traps

**434.17.1** Scraper traps are to be installed as deemed necessary for good operations. All pipe, valves, fittings, closures, and appurtenances shall comply with appropriate sections of this Code.

**434.17.2** Scraper traps on mainline terminations and tied into connection piping or manifolding shall be anchored belowground with adequate concrete anchors when required and suitably supported aboveground to prevent transmission of line stresses due to expansion and contraction to connecting facilities.

**434.17.3** Scraper trap and its components shall be assembled in accordance with [section 435](#), and pressure tested to the same limits as the main line. See [para. 437.4](#).

**434.17.4** All in-line mainline pipeline scraper traps shall accommodate the passage of instrumented internal inspection devices during launching and receiving operations.

### (19) 434.18 Line Markers

(a) Except as provided in (d) below, adequate pipeline location markers for the protection of the pipeline, the public, and persons performing work in the area shall be placed over each buried pipeline in accordance with the following:

(1) Markers shall be located at each public road crossing, at each railroad crossing, at each navigable stream crossing, and in sufficient numbers along the remainder of the buried line so that the pipeline location, including direction of the pipeline, is adequately known. It is recommended that markers are installed on each side of each crossing whenever possible.

(2) Markers shall be installed at locations where the line is aboveground in areas that are accessible to the public.

(b) The marker shall state at least the following on a background of sharply contrasting colors:

(1) The word "Warning," "Caution," or "Danger" followed by the words "Petroleum (or the name of the hazardous liquid transported) Pipeline" or "Slurry Pipeline," all of which, except for markers in heavily developed urban areas, shall be in letters at least 1 in. (25 mm) high with an approximate stroke of 1/4 in. (6 mm).

(2) The name of the operator and a telephone number (including area code) where the operator can be reached at all times.

(c) API RP 1109 should be used for additional guidance.

(d) Unless required by applicable regulatory agencies, line markers are not required for buried pipelines located offshore or under waterways and other bodies of water, or in heavily developed urban areas such as downtown business centers where the placement of markers is impractical and would not serve the purpose for which markers are intended and the local government maintains substructure records.

### 434.19 Corrosion Control

Protection of ferrous pipe and components from external and internal corrosion shall be as prescribed in [Chapter VIII](#).

### 434.20 Pump Station, Tank Farm, and Terminal Construction

**434.20.1 General.** All construction work performed on pump stations, tank farms, terminals, equipment installations, piping, and allied facilities shall be done under construction specifications. Such specifications shall cover all phases of the work under contract and shall be in sufficient detail to ensure that the requirements of this Code shall be met. Such specifications shall include specific details on soil conditions, foundations and concrete work, steel fabrication and building erection, piping, welding, equipment and materials, and all construction factors contributing to safety and sound engineering practice.

**434.20.2 Location.** Pump stations, tank farms, and terminals should be located on the pipeline's fee or leased property in order to ensure that proper safety precautions may be applied. The pump station, tank farm, or terminal shall be located at such clear distances from adjacent properties not under control of the company as to minimize the communication of fire from structures on adjacent properties. Similar consideration shall be given to its relative location from the station manifolds, tankage, maintenance facilities, personnel housing, etc. Sufficient open space shall be left around the building and manifolds to provide access for maintenance equipment and firefighting equipment. The station, tank farm, or terminal shall be fenced in such a manner as to minimize trespass, and roadways and gates should be located to give ready access to or egress from the facilities.

**434.20.3 Building Installation.** Buildings shall be located and constructed to comply with detailed plans and specifications. The excavation for and installation of foundations and erection of the building shall be done by craftsmen familiar with the respective phase of the work, and all work shall be done in a safe and



workmanlike manner. Inspection shall be provided to ensure that the requirements of the plans and specifications are met.

#### **434.20.4 Pumping Equipment and Prime Movers.**

Installation of pumping equipment and prime movers shall be covered by detailed plans and specifications that have taken into account the variables inherent in local soil conditions, utilization, and arrangement of the equipment to provide the optimum in operating ease and maintenance access. Machinery shall be handled and mounted in accordance with recognized good millwright practice and be provided with such protective covers as to prevent damage during construction. Recommendations of installation details provided by manufacturers for auxiliary piping, setting, and aligning shall be considered as minimum requirements.

**434.20.5 Pump Station, Tank Farm, and Terminal Piping.** All piping, including but not limited to main unit interconnections, manifolds, scraper traps, etc., that can be subject to the mainline pressure shall be constructed in accordance with the welding standards (see [para. 434.8](#)), corrosion control requirements (see [Chapter VIII](#)), and other practices of this Code.

**434.20.6 Controls and Protective Equipment.** Pressure controls and protective equipment, including pressure-limiting devices, regulators, controllers, relief valves, and other safety devices, as shown on the drawings or required by the specifications, shall be installed by competent and skilled workmen. Installation shall be accomplished with careful handling and minimum exposure of instruments and devices to inclement weather conditions, dust, or dirt to prevent damage. Also, piping, conduits, or mounting brackets shall not cause the instruments or devices to be distorted or in any strain. Instruments and devices shall be installed so that they can be checked without undue interruptions in operations. After installation, controls and protective equipment shall be tested under conditions approximating actual operations to ensure their proper functioning.

**434.20.7 Fire Protection.** Fire protection when provided shall be in accordance with recommendations in NFPA 30. If the system installed requires the services of fire pumps, their motive power shall be separate from the station power so that their operation shall not be affected by emergency shutdown facilities.

### **434.21 Storage and Working Tankage**

**434.21.1 General.** All construction work performed on storage and working tankage and allied equipment, piping, and facilities shall be done under construction specifications. Such specifications shall cover all phases of the work under contract, and shall be in sufficient detail to ensure that the requirements of the Code shall be met. Such specifications shall include specific

details on soil conditions, foundations and concrete work, tank fabrication and erection, piping, welding, equipment and materials, dikes, and all construction factors contributing to safety and sound engineering practice.

#### **434.21.2 Location**

(a) Tankage or slurry holding ponds shall be located on the pipeline's fee or leased property in order to ensure that proper safety precautions may be applied. Tank facilities or slurry holding ponds shall be located at such clear distances from adjacent properties not under control of the company as to minimize the communication of fire from structures on adjacent properties. Similar consideration shall be given to relative locations between station manifolds, pumping equipment, maintenance facilities, personnel housing, etc. Sufficient open space shall be left around the tankage facilities or slurry holding ponds and associated equipment to provide access for maintenance and firefighting equipment. The tankage or slurry holding pond area shall be fenced so as to minimize trespass, and roadways and gates should be located to give ready ingress to and egress from the facilities.

(b) Spacing of tankage shall be governed by the requirements of NFPA 30.

#### **434.21.3 Tanks and Pipe-Type Storage**

(a) Tanks for storage or handling of crude oil and liquid petroleum products and liquid alcohols having vapor pressures approximating atmospheric shall be constructed in accordance with API 650, API 12B, API 12D, API 12F, or designed and constructed in accordance with accepted good engineering practices.

(b) Tanks for storage or handling of liquid petroleum products and liquid alcohols having vapor gage pressures of 0.5 psi (0.035 bar) but not exceeding 15 psi (1 bar) shall be constructed in accordance with API 620.

(c) Tanks used for storage or handling of liquids having vapor gage pressures greater than 15 psi (1 bar) shall be designed and constructed in accordance with the design of accredited tank builders and ASME BPVC, Section VIII, Division 1 or Division 2.

(d) Buried pipe-type holders used for storage and handling of liquid petroleum, liquid alcohols, or liquid anhydrous ammonia shall be designed and constructed in accordance with the requirements of this Code for pipe and piping components.

**434.21.4 Foundations.** Tank foundations shall be constructed in accordance with plans and specifications that shall take into account local soil conditions, type of tank, usage, and general location.

**434.21.5 Dikes or Firewalls.** The protection of the pipeline's station, tank farm, terminal, or other facilities from damage by fire from adjacent facilities, as well as the

protection of the general public, may dictate the need of dikes or firewalls around tankage or between tankage and station or terminal. Tank dikes or firewalls, where required, shall be constructed to meet the capacity requirements set out in NFPA 30.

#### 434.22 Electrical Installations

**434.22.1 General.** Electrical installations for lighting, power, and control shall be covered by detailed plans and specifications, and installations shall be in accordance with codes applicable to the specific type of circuitry and classification of areas for electrical installation. Inspection shall be provided and all circuitry shall be tested before operation to ensure that the installation was made in workmanlike manner to provide for the continuing safety of personnel and equipment. Installations shall be made in accordance with NFPA 70 and API RP 500C.

**434.22.2 Care and Handling of Materials.** All electrical equipment and instruments shall be carefully handled and properly stored or enclosed to prevent damage, deterioration, or contamination during construction. Packaged components are not to be exposed until installation. Equipment susceptible to damage or deterioration by exposure to humidity shall be adequately protected by using appropriate means such as plastic film enclosures, desiccants, or electric heating.

**434.22.3 Installation.** The installation of electrical materials shall be made by qualified personnel familiar with details of electrical aspects and code requirements for such installation. At all times, care shall be exercised to prevent damage to the insulation of cable and wiring. All partial installations shall be protected from damage during construction. The installation design and specifications shall give consideration to the need for dust-proof and/or moisture-proof enclosures for such special gear as relays, small switches, and electronic components. In no case shall the frames of electric motors or other grounded electrical equipment be used as the ground connection for electrical welding.

#### 434.23 Liquid Metering

**434.23.1** Positive displacement meters, turbine meters, or equivalent liquid-measuring devices and their proving facilities shall be designed and installed in accordance with the API Manual of Petroleum Measurement Standards.

**434.23.2** Provisions shall be made to permit access to these facilities by authorized personnel only.

**434.23.3** Assembly of the metering facility components shall be in accordance with [section 435](#).

#### 434.24 Liquid Strainers and Filters

**434.24.1** Strainers and filters shall be designed to the same pressure limitations and subjected to the same test pressures as the piping system in which they are installed, and supported in such a manner as to prevent undue loading to the connecting piping system.

**434.24.2** Installation and design shall provide for ease of maintenance and servicing without interference with the station operation.

**434.24.3** The filtering medium should be of such retention size and capacity as to fully protect the facilities against the intrusion of harmful foreign substances.

**434.24.4** Assembly of strainers or filters and their components shall be in accordance with [section 435](#).

### 435 ASSEMBLY OF PIPING COMPONENTS

#### 435.1 General

The assembly of the various piping components, whether done in a shop or as a field erection, shall be done so that the completely erected piping conforms with the requirements of this Code and with the specific requirements of the engineering design.

#### 435.2 Bolting Procedure

**435.2.1** All flanged joints shall be fitted up so that the gasket contact faces bear uniformly on the gasket, and made up with uniform bolt stress.

**435.2.2** In bolting gasketed flanged joints, the gasket shall be properly compressed in accordance with the design principles applicable to the type of gasket used.

**435.2.3** All bolts or studs shall extend completely through their nuts.

#### 435.3 Pumping Unit Piping

**435.3.1** Piping to main pumping units shall be so designed and supported that when assembled to the pump flanges and valves it should be relatively free of stress and should not add stress or load to the pump frame.

**435.3.2** The design and assembly shall take into account the forces of expansion and contraction to minimize their effect within the assembly.

**435.3.3** All valves and fittings on pumping units shall carry the same pressure ratings as required for line operating pressures.

**435.3.4** Welding shall be in accordance with [para. 434.8](#).

**435.3.5** Bolting shall be in accordance with [para. 435.2](#).

#### 435.4 Manifolds

**435.4.1** All components within a manifold assembly, including valves, flanges, fittings, headers, and special assemblies, shall withstand the operating pressures and specified loadings for the specific service piping to which it is connected.

**435.4.2** Meter banks, prover loops, and scraper traps shall be subject to the same assembly requirements as manifolds.

- (19) **435.4.3** Manifold headers with multiple outlets shall have outlets designed as specified in [para. 404.3](#). Assembly may be with the use of jigs to ensure alignment of outlets and flanges with other components. The fabricated unit shall be stress relieved before removal from the jig.

**435.4.4** Manifold headers assembled from wrought tees, fittings, and flanges may be assembled with jigs to ensure alignment of components. Stress relieving should be considered.

**435.4.5** All welding on manifolds and headers shall conform to [para. 434.8](#).

**435.4.6** Final assembly of all components shall minimize locked-in stresses. The entire assembly shall be adequately supported to provide minimum unbalance and vibration.

#### 435.5 Auxiliary Piping

**435.5.1** All auxiliary piping between main units and auxiliary components shall be assembled in a workmanlike manner and in accordance with the applicable code.

**435.5.2** All welded auxiliary lines shall be assembled in accordance with the requirements of this Code with special provisions as required for assembly to minimize locked-in stress, and for adequate support or restraint to minimize vibration.

## Chapter VI

# Inspection and Testing

### 436 INSPECTION

#### 436.1 General

Construction inspection provisions for pipelines and related facilities shall be adequate to ensure compliance with the material, construction, welding, assembly, and testing requirements of this Code.

#### 436.2 Qualification of Inspectors

Inspection personnel shall be qualified by training and experience. Such personnel shall be capable of performing the following inspection services:

- (a) right-of-way and grading
- (b) ditching
- (c) use of explosives
- (d) road and railroad casing and crossing
- (e) pipe stringing and pipe and material handling
- (f) bending
- (g) lineup and pipe surface inspection
- (h) welding
- (i) coating
- (j) tie-in and lowering
- (k) backfilling and cleanup
- (l) pressure testing
- (m) special services for testing and inspection of facilities, such as station construction, river crossings, electrical installation, radiography, corrosion control, double jointing, etc., as may be required

#### 436.5 Type and Extent of Examination Required

##### 436.5.1 Visual

###### (a) Material

(1) All piping components shall be visually inspected to ensure that no mechanical damage has occurred during shipment and handling prior to being connected into the piping system.

(2) All pipe shall be visually inspected to discover any defects as described in [paras. 434.5](#) and [434.8.7](#).

(3) On systems where pipe is telescoped by grade, wall thickness, or both, particular care shall be taken to ensure proper placement of pipe. Permanent records shall be kept showing the location as installed of each grade, wall thickness, type, specification, and manufacturer of the pipe.

###### (b) Construction

(1) Visual inspection for detection of surface defects in the pipe shall be provided for each job just ahead of any coating operation and during the lowering-in and backfill operation.

(2) The pipe swabbing operation shall be inspected for thoroughness to provide a clean surface inside the pipe.

(3) Before welding, the pipe shall be examined for damage-free bevels and proper alignment of the joint.

(4) All welding operations shall be inspected to verify that welding is being performed in accordance with qualified welding procedures by qualified welders.

(5) The stringer bead shall be inspected, particularly for cracks, before subsequent beads are applied.

(6) The completed weld shall be cleaned and inspected prior to coating operations, and irregularities that could protrude through the pipe coating shall be removed.

(7) When the pipe is coated, inspection shall be made to determine that the coating machine does not cause harmful gouges or grooves in the pipe surface.

(8) Lacerations of the pipe coating shall be inspected prior to repair of coating to see if the pipe surface has been damaged. Damaged coating and pipe shall be repaired before the pipe is lowered in the ditch.

(9) All repairs, changes, or replacements shall be inspected before they are covered up.

(10) The condition of the ditch shall be inspected before the pipe is lowered in to ensure proper protection of pipe and coating. For underwater crossings, the condition of the ditch and fit of the pipe to the ditch shall be inspected when feasible.

(11) The fit of the pipe to ditch shall be inspected before the backfilling operations.

(12) The backfilling operations shall be inspected for quality and compaction of backfill, placement of material for the control of erosion, and possible damage to the pipe coatings.

(13) Cased crossings shall be inspected during installation to determine that the carrier pipe is supported, sealed, and insulated from the casing.

(14) River crossings shall have thorough inspection, and shall be surveyed and profiled after construction.

(15) All piping components other than pipe shall be inspected to ensure damage-free condition and proper installation.

(16) Stringing operations shall be inspected to verify use of proper pipe handling techniques and that the pipe is not being damaged.

(17) When explosives are used during grading and ditching operations, inspections shall be made to verify use of proper techniques and maintenance of records.

(18) The bending operations shall be inspected to verify that the maximum allowable angle of bend is not exceeded and that there is no wrinkling or excessive flattening of the pipe.

#### 436.5.2 Supplementary Types of Examination

(a) Testing of field and shop welds shall be made in accordance with [para. 434.8.5](#).

(b) Radiographic inspection of welds shall be performed in accordance with [para. 434.8.5](#).

(c) Coated pipe shall be inspected in accordance with [para. 461.1.2](#).

(d) Pipeline segments installed by directional drilling shall be inspected for cross section deformation by running a sizing plate or caliper pig through the crossing after installation but prior to removing the drilling equipment from the work site or tying in the crossing to the pipeline system.

#### 436.6 Repair of Defects

**436.6.1** Defects of fabricated items and in pipe wall shall be repaired or eliminated in accordance with [para. 434.5](#).

**436.6.2** Welding defects shall be repaired in accordance with [para. 434.8.7](#).

**436.6.3** Holidays or other damage to coating shall be repaired in accordance with [para. 461.1.2](#).

### 437 TESTING

#### 437.1 General

(a) In order to meet requirements of this Code, it is necessary that tests be made upon the completed system and upon component parts of the finished system. When reference in this Code is made to tests or portions of tests described in other codes and specifications, they shall be considered as a part of this Code.

(b) Should leaks occur on tests, the line section or component part shall be repaired or replaced and retested in accordance with this Code.

##### 437.1.3 Testing of Fabricated Items

(a) Fabricated items such as scraper traps, manifolds, volume chambers, etc., shall be hydrostatically tested to limits equal to or greater than those required of the

completed system. This test may be conducted separately or as a part of the completed system.

(b) In testing fabricated items before installation, the applicable paragraphs of specifications listed in [Table 423.1-1](#) shall apply.

#### 437.1.4 Testing After New Construction

##### (a) Systems or Parts of Systems

(1) All liquid and slurry transportation piping systems within the scope of this Code, regardless of stress, shall be tested after construction.

(2) Systems to be operated at a hoop stress of more than 20% of the specified minimum yield strength of the pipe shall be hydrostatically tested in accordance with [para. 437.4.1](#).

(3) Systems to be operated at a hoop stress of 20% or less of specified minimum yield strength of the pipe may be subjected to a leak test in accordance with [para. 437.4.3](#) in lieu of the hydrostatic test specified in [para. 437.4.1](#).

(4) When testing piping, in no case shall the test pressure exceed that stipulated in the standards of material specifications (except pipe) incorporated in this Code by reference and listed in [Table 423.1-1](#) for the weakest element in the system, or portion of system, being tested.

(5) Equipment not to be subjected to test pressure shall be disconnected from the piping or otherwise isolated. Valves may be used if the valve, including closing mechanism, is suitable for the test pressure.

(b) *Testing Tie-Ins.* Because it is sometimes necessary to divide a pipeline into test sections and install test heads, connecting piping, and other necessary appurtenances for testing, or to install a pretested replacement section, it is not required that tie-in welds be tested; however, tie-in welds and girth welds joining lengths of pretested pipe shall be inspected by radiographic or other accepted non-destructive methods in accordance with [para. 434.8.5\(b\)](#) if the system is not pressure tested after tie-in. After such inspection, the joint shall be coated and inspected in accordance with [para. 461.1.2](#) before backfilling.

(c) *Testing Controls and Protective Equipment.* All controls and protective equipment, including pressure-limiting devices, regulators, controllers, relief valves, and other safety devices, shall be tested to determine that they are in good mechanical condition; of adequate capacity, effectiveness, and reliability of operation for the service in which they are employed; functioning at the correct pressure; and properly installed and protected from foreign materials or other conditions that might prevent proper operation.

**437.1.5 Testing of Replacement Components.** Components other than pipe that are being replaced or added to the pipeline system need not be hydrostatically tested if the manufacturer certifies that either each component was hydrostatically tested at the factory, or each component was manufactured under a quality control system that ensures each component is at least equal in strength



to a prototype that was hydrostatically tested at the factory. Tie-in butt welds are subject to the same nondestructive tests as in [para. 451.6.3](#).

## 437.4 Test Pressure

### (19) 437.4.1 Hydrostatic Testing of Internal Pressure Piping

(a) Portions of piping systems to be operated at a hoop stress of more than 20% of the specified minimum yield strength of the pipe shall be subjected at any point to a hydrostatic proof test equivalent to not less than 1.25 times the internal design pressure at that point (see [para. 401.2.2.2](#)) for not less than 4 hr. When lines are tested at pressures that develop a hoop stress, based on nominal wall thickness, in excess of 90% of the specified minimum yield strength of the pipe, special care shall be used to prevent overstrain of the pipe.

(1) Those portions of piping systems where all of the pressured components are visually inspected during the proof test to determine that there is no leakage require no further test. This can include lengths of pipe that are pretested for use as replacement sections.

(2) On those portions of piping systems not visually inspected while under test, the proof test shall be followed by a reduced pressure leak test equivalent to not less than 1.1 times the internal design pressure for not less than 4 hr.

(b) API RP 1110 may be used for guidance for the hydrostatic test.

(c) The hydrostatic test shall be conducted with water, except liquid petroleum that does not vaporize rapidly may be used, provided

(1) the pipeline section under test is not offshore and is outside of cities and other populated areas, and each building within 300 ft (90 m) of the test section is unoccupied while the test pressure is equal to or greater than a pressure that produces a hoop stress of 50% of the specific minimum yield strength of the pipe

(2) the test section is kept under surveillance by regular patrols during test

(3) communication is maintained along the test section

(d) If the testing medium in the system will be subject to thermal expansion during the test, provisions shall be made for relief of excess pressure. Effects of temperature changes shall be taken into account when interpretations are made of recorded test pressures.

(e) After completion of the hydrostatic test, it is important in cold weather that the lines, valves, and fittings be drained completely of any water to avoid damage due to freezing.

### (19) 437.4.3 Leak Testing. A minimum 1-hr hydrostatic or pneumatic leak test shall be used for piping systems to be operated at a hoop stress of 20% or less of the specified minimum yield strength of the pipe. The test pressure shall

not be less than 1.25 times the internal design pressure. If the required test gage pressure exceeds 100 psi (7 bar), pneumatic testing is not allowed.

## 437.6 Qualification Tests

Where tests are required by other sections of this Code, the procedures in [paras. 437.6.1](#) through [437.6.7](#) shall be used.

**437.6.1 Visual Examination.** Used or new pipe to be laid shall be visually examined in accordance with [para. 436.5.1](#).

### 437.6.2 Bending Properties

(a) For pipe of unknown specification or ASTM A120, bending properties are required if the minimum yield strength used for design is above 24,000 psi (165 MPa), and after the type of joint has been identified in accordance with [para. 437.6.4](#). For pipe NPS 2 and smaller, a bending test shall meet the requirements of ASTM A53 or API 5L. For pipe larger than NPS 2 in nominal diameter, flattening tests shall meet the requirements in ASTM A53 or API 5L.

(b) The number of tests required to determine bending properties shall be the same as required in [para. 437.6.6](#) to determine yield strength.

**437.6.3 Determination of Wall Thickness.** When the nominal wall thickness is not known, it shall be determined by measuring the thickness at quarter points on one end of each piece of pipe. If the lot of pipe is known to be of uniform grade, size, and nominal thickness, measurement shall be made on not less than 5% of the individual lengths, but not less than 10 lengths; thickness of the other lengths may be verified by applying a gage set to the minimum thickness. Following such measurement, the nominal wall thickness shall be taken as the next nominal wall thickness below the average of all the measurements taken, but in no case greater than 1.14 times the least measured thickness for all pipe under NPS 20, and no greater than 1.11 times the least measured thickness for all pipe NPS 20 and larger.

**437.6.4 Determination of Weld Joint Factor.** If the (19) type of longitudinal or helical seam weld joint is known, the corresponding weld joint factor ([Table 403.2.1-1](#)) may be used. Otherwise, the factor  $E$  shall not exceed 0.60 for pipe NPS 4 and smaller, or 0.80 for pipe over NPS 4.

**437.6.5 Weldability.** For steel pipe of unknown specification, weldability shall be determined as follows. A qualified welder shall make a girth weld in the pipe. This weld shall be tested in accordance with the requirements of [para. 434.8.5](#). The qualifying weld shall be made under the most severe conditions under which welding will be permitted in the field and using the same procedure as to be used in the field. The pipe shall be considered

weldable if the requirements set forth in [para. 434.8.5](#) are met. At least one such test weld shall be made for each number of lengths to be used as listed below.

Minimum Number of Test Welds	
Nominal Pipe Size	Number of Lengths per Test
Less than 6	400
6 through 12	200
Larger than 12	100

All test specimens shall be selected at random.

**437.6.6 Determination of Yield Strength.** When the specified minimum yield strength, minimum tensile strength, or minimum percent of elongation of pipe is unknown, the tensile properties may be established as follows.

Perform all tensile tests prescribed by API 5L or API 5LU, except that the minimum number of such tests shall be as follows:

Nominal Pipe Size	Number of Lengths per Test
Less than 6	200
6 through 12	100
Larger than 12	50

All test specimens shall be selected at random.

**437.6.7 Minimum Yield Strength Value.** For pipe of unknown specification, the minimum yield strength may be determined as follows.

Average the value of all yield strength tests for a test lot. The minimum yield strength shall then be taken as the lesser of the following:

(a) 80% of the average value of the yield strength tests

(b) the minimum value of any yield strength test, except that in no case shall this value be taken as greater than 52,000 psi (358 MPa)

(c) 24,000 psi (165 MPa) if the average yield-tensile ratio exceeds 0.85

### 437.7 Records

A record shall be maintained in the files of the operating company relative to design, construction, and testing of each main line within the scope of this Code. These records shall include material specifications; route maps and alignments sheets for “as-built” condition; location of each pipe size, grade, wall thickness, type of seam (if any), and manufacturer; coatings; and test data. These records shall be kept for the life of the facility. See [para. 436.5.1\(a\)\(3\)](#).



## Chapter VII

# Operation and Maintenance Procedures

### 450 OPERATION AND MAINTENANCE PROCEDURES AFFECTING THE SAFETY OF LIQUID AND SLURRY TRANSPORTATION PIPING SYSTEMS

#### 450.1 General

(a) It is not possible to prescribe in this Code a detailed set of operating and maintenance procedures that will encompass all cases. It is possible, however, for each operating company to develop operating and maintenance procedures based on the provisions of this Code, and the company's experience and knowledge of its facilities and conditions under which they are operated, that will be adequate from the standpoint of public safety.

(b) The methods and procedures set forth herein serve as a general guide but do not relieve the individual or operating company of the responsibility for prudent action that current particular circumstances make advisable.

(c) It must be recognized that local conditions (such as the effects of temperature, characteristics of the line contents, and topography) will have considerable bearing on the approach to any particular maintenance and repair job.

(d) Suitable safety equipment shall be available for personnel use at all work areas and operating facilities where liquid anhydrous ammonia is transported. Such safety equipment shall include at least the following:

- (1) full-face gas mask with anhydrous ammonia refill canisters
- (2) independently supplied air mask
- (3) tight-fitting goggles or full face shield
- (4) protective gloves
- (5) protective boots
- (6) protective slicker and/or protective pants and jacket
- (7) easily accessible shower and/or at least 50 gal (190 L) of clean water in an open top container

Personnel shall be instructed in effective use of masks and limited shelf life of refill canisters. Protective clothing shall be of rubber fabric or other ammonia-impervious material.

#### 450.2 Operation and Maintenance Plans and Procedures

Each operating company having a transportation piping system within the scope of this Code shall

(a) have written detailed plans and training programs for employees covering operating and maintenance procedures for the transportation piping system during normal operations and maintenance in accordance with the purpose of this Code. Essential features recommended for inclusion in the plans for specific portions of the system are given in [sections 451](#) and [452](#).

(b) have a plan for external and internal corrosion control of new and existing piping systems, including requirements and procedures prescribed in [section 453](#) and [Chapter VIII](#).

(c) have a written emergency plan as indicated in [section 454](#) for implementation in the event of system failures, accidents, or other emergencies. Train appropriate operating and maintenance employees with regard to applicable portions of the plan, and establish liaison with appropriate public officials with respect to the plan.

(d) have a plan for reviewing changes in conditions affecting the integrity and safety of the piping system, including provisions for periodic patrolling and reporting of construction activity and changes in conditions, especially in industrial, commercial, and residential areas and at river, railroad, and highway crossings, in order to consider the possibility of providing additional protection to prevent damage to the pipeline in accordance with [para. 402.1](#).

(e) establish liaison with local authorities who issue construction permits in urban areas to prevent accidents caused by excavators.

(f) establish procedures to analyze all failures and accidents for the purpose of determining the cause and to minimize the possibility of recurrence.

(g) maintain necessary maps and records to properly administer the plans and procedures, including records listed in [section 455](#).

(h) have procedures for abandoning piping systems, including the requirements in [section 457](#).

(i) in establishing plans and procedures, give particular attention to those portions of the system presenting the greatest hazard to the public in the event of emergencies

or because of construction or extraordinary maintenance requirements.

(j) operate and maintain its piping system in conformance with these plans and procedures.

(k) modify the plans and procedures from time to time as experience dictates and as exposure of the system to the public and changes in operating conditions require.

(l) participate in government-sponsored or industry-sponsored excavation notification programs.

## 451 PIPELINE OPERATION AND MAINTENANCE

### 451.1 Operating Pressure

(a) Care shall be exercised to ensure that at any point in the piping system the maximum steady-state operating pressure and static head pressure with the line in a static condition do not exceed at that point the internal design pressure and pressure ratings for the components used as specified in [para. 401.2.2.2](#), and that the level of pressure rise due to surges and other variations from normal operation does not exceed the internal design pressure at any point in the piping system and equipment by more than 10% as specified in [para. 403.3.4](#).

(b) A piping system shall be qualified for a higher operating pressure when the higher operating pressure will produce a hoop stress of more than 20% of the specified minimum yield strength of the pipe in accordance with [section 456](#).

(c) If a piping system is derated to a lower operating pressure in lieu of repair or replacement, the new maximum steady-state operating pressure shall be determined in accordance with [para. 451.6.2.2\(b\)](#).

(d) For existing systems utilizing materials produced under discontinued or superseded standards or specifications, the internal design pressure shall be determined using the allowable stress and design criteria listed in the issue of the applicable code or specification in effect at the time of the original construction.

### 451.2 Communications

A communications facility shall be maintained to ensure safe pipeline operations under both normal and emergency conditions.

### 451.3 Line Markers and Signs

(a) Line markers shall be installed and maintained over each line at each public road crossing, at each railroad crossing, at each navigable stream crossing, and in sufficient number along the remainder of the pipeline route to properly locate and identify the buried pipeline. See [para. 434.18](#).

(b) Pipeline markers at crossings, aerial markers when used, and other signs shall be maintained so as to indicate the location of the line and to provide the required information on the pipeline. Additional pipeline markers shall

be installed and maintained along the pipeline in areas of development and growth to protect the pipeline from encroachment.

### 451.4 Right-of-Way Maintenance

(a) The right-of-way should be maintained to provide clear visibility for the periodic patrolling described in [para. 451.5](#). A properly maintained right-of-way provides effective access for expeditious, safe response to emergency situations.

(b) Proper right-of-way maintenance includes the following:

(1) controlling vegetation growth

(2) preventing encroachment from above- and belowground structures

(3) controlling erosion

(4) maintaining access to pipeline systems

(5) maintaining visibility of pipeline markers

(c) Diversion ditches or dikes shall be maintained where needed to protect against washouts of the line and erosion of the landowner's property.

### 451.5 Patrolling

(a) Each operating company shall maintain a periodic pipeline patrol program to observe surface conditions on and adjacent to the pipeline right-of-way, indication of leaks, construction activity other than that performed by the company, and any other factors affecting the safety and operation of the pipeline. Special attention shall be given to such activities as road building, ditch cleanouts, excavations, cultivated areas where deep plowing or subsurface ripping is common, and like encroachments to the pipeline system. Patrols shall be made at intervals not exceeding 2 weeks, except that piping systems transporting LPG or liquid anhydrous ammonia shall be patrolled at intervals not exceeding 1 week in industrial, commercial, or residential areas.

(b) Underwater crossings shall be inspected periodically for sufficiency of cover, accumulation of debris, or for any other condition affecting the safety and security of the crossings, and at any time it is felt that the crossings are in danger as a result of floods, storms, or suspected mechanical damage.

### 451.6 Pipeline Integrity Assessments and Repairs

#### 451.6.1 General

(19)

(a) Each operator of pipelines designed in accordance with this Code should consider the need for periodic integrity assessments of those pipelines. An integrity assessment may consist of a hydrostatic test of the pipeline, an in-line inspection (ILI) followed by remediation of anomalies indicated by the inspection to be possibly injurious, or other technical means that can provide a level of integrity assessment equivalent to a hydrostatic test or an ILI. For

guidance on the integrity-assessment process, the operator may refer to API 1160.

When assessing pipeline integrity, each operator should develop criteria for evaluating anomalies identified through ILI methods, through visual inspection, or through other technical means. API 1160 provides guidance for evaluating anomalies.

(b) Defect repair criteria and repair methods are described below as a guideline for pipeline operators to use when addressing anomalies discovered on their pipelines. It is recognized that a pipeline operator may elect to perform an engineering critical assessment (ECA) to identify alternate repair criteria or other mitigative methods as defined in API 1160.

(c) Repairs shall be covered by a maintenance plan [see [para. 450.2\(a\)](#)] and shall be performed under qualified supervision by trained personnel familiar with the hazards to public safety. The maintenance plan shall consider the appropriate information contained in API RP 2200, API 2201, API 1104, and API RP 1111. It is essential that all personnel working on pipeline repairs understand the need for careful planning of the job, be briefed as to the procedures to be followed in accomplishing the repairs, and follow precautionary measures and procedures outlined in API RP 2200. Personnel working on repairs to pipelines handling liquids requiring special safety precautions such as LPG, liquid alcohol, or liquid anhydrous ammonia shall also be informed on the specific properties, characteristics, and potential hazards associated with those liquids, precautions to be taken following detection of a leak, and safety repair procedures set forth for LPG pipelines in API RP 2200. Piping in the vicinity of any repair shall be adequately supported during and after the repair.

(d) If an inert gas, such as nitrogen, is used to temporarily displace the liquid in a pipeline system for the purpose of a repair, a detailed written procedure shall be required. Because the potential energy of a gas presents special concerns, this procedure should address, as a minimum, the following factors related to the use of an inert gas:

- (1) maximum flow rate of the fluid being displaced
- (2) maximum pressure at the injection site of the inert gas
- (3) injection temperature
- (4) inert gas handling to eliminate the risks to personnel
- (5) safety procedures such as overpressure protection

This procedure shall be followed under the supervision required in (c).

(e) *Anomalies*

(1) Whenever a specific ILI anomaly is to be excavated, inspected, and evaluated for repair, the possibility of sudden failure of the anomaly must be recognized. To minimize the risks to personnel and facilities, the internal

pressure in the pipeline should be reduced to a level that would be expected to prevent an anomaly from failing while the excavation, inspection, and repair are in progress. In this respect, the following two types of anomalies are relevant:

(-a) anomalies for which the remaining strength can be calculated

(-b) anomalies of unknown significance

(2) When a pipeline operator is excavating and physically evaluating an anomaly for possible repair or excavating and physically responding to an ILI where the data indicate the presence of an anomaly that may affect the integrity of the pipeline, the pressure at the location of the anomaly should be reduced as follows depending on the type of anomaly:

(-a) For anomalies for which the remaining strength can be calculated, the pressure at the location of the anomaly should be reduced to the greater of the calculated safe operating pressure or 80% of the maximum steady-state pressure from recent operating history.

(-b) For anomalies of unknown significance operating at a pressure equal to or greater than 40%  $S_y$ , the pressure at the location of the anomaly should be reduced to 80% of the maximum steady-state pressure from recent operating history.

The flow of the pipeline segment should not be stopped if the resulting static pressure at the location of the anomaly exceeds 80% of the maximum steady-state pressure from recent operating history.

(f) Materials used for pipeline repair shall be in accordance with [Chapter III](#) and this section.

(g) Repair welding procedures and welders performing repair work shall be qualified in accordance with API 1104 or ASME BPVC, Section IX. The welders shall also be familiar with safety precautions and other problems associated with cutting and welding on pipe that is or has been in service. Cutting and welding shall commence only after compliance with [para. 434.8.1\(c\)](#). See ASME PCC-2, Article 2.6, para. 4.6 for more information about welding on pipe containing liquid.

The qualification test for welding procedures to be used on pipe containing a liquid shall include the cooling effects of the pipe contents on the soundness and physical properties of the weld. Welding procedures on pipe not containing liquid shall be qualified in accordance with [para. 434.8.3](#).

Repairs to pipelines in service shall be inspected visually and by magnetic-particle or dye-penetrant inspection methods where appropriate. All welds made in contact with a carbon steel carrier pipe shall be inspected for cracks using magnetic-particle inspection techniques. At least 90% of the welds shall be inspected no sooner than 12 hr after completion of the welding. Areas that have been dressed by grinding to remove cracks or other stress risers shall be inspected using

magnetic-particle or dye-penetrant techniques to ensure that all cracks have been removed.

(h) Coating damaged during the repair process shall be removed and new coating applied in accordance with para. 461.1.2.

Replacement pieces of pipe, areas that are exposed for examination by removal of coating, and any appurtenances or components added for the purpose of repair shall be coated when installed in a coated line.

#### 451.6.2 Limits and Disposition of Imperfections and Anomalies

**451.6.2.1 Limits.** Pipe containing leaks shall be removed or repaired.

##### 451.6.2.2 Corrosion

(a) *External or Internal Corrosion.* Areas of external or internal metal loss with a maximum depth greater than 80% of the wall thickness shall be removed or repaired. An appropriate fitness-for-purpose criterion may be used to evaluate the longitudinal profile of corrosion-caused metal loss in base metal of the pipe or of nonpreferential corrosion-caused metal loss that crosses a girth weld or impinges on a submerged arc welded seam.

(b) *External Corrosion.* Externally corroded areas exposed for examination shall be cleaned to bare metal. In general, areas of corrosion with a maximum depth of 20% or less of the thickness required for design,  $t$ , need not be repaired. However, measures should be taken to prevent further corrosion. An area of corrosion with maximum depth greater than 20% but less than or equal to 80% of the wall thickness shall be permitted to remain in the pipeline unrepaired, provided that safe operating pressure is established. Generally acceptable methods for calculating a safe operating pressure include ASME B31G, "modified B31G," and an effective area method (e.g., RSTRENG).

For pipelines subjected to unusual axial loads, lateral movement, or settlement, or for pipelines comprised of materials with yield-to-tensile ratios exceeding 0.93, an engineering analysis shall be performed to establish a safe operating pressure.

If the safe operating pressure is less than the maximum operating pressure, the affected area shall be removed or repaired or the maximum operating pressure shall be reduced to the safe operating pressure or less.

(c) *Internal Corrosion.* The limitations for areas with internal corrosion and areas with a combination of internal and external corrosion are the same as for external corrosion. When dealing with internal corrosion, consideration should be given to the uncertainty related to the indirect measurement of wall thickness and the possibility that internal corrosion may require continuing mitigative efforts to prevent additional metal loss.

(d) *Interaction of Corrosion-Caused Metal Loss Areas.* Two or more areas of corrosion-caused metal loss that are separated by areas of full wall thickness may interact in a manner that reduces the remaining strength to a greater extent than the reduction resulting from the individual areas. Two types of interaction are possible and each should be assessed as follows:

(1) *Type I Interaction (see Figure 451.6.2.2-1).* If the circumferential separation distance,  $C$ , is greater than or equal to 6 times the wall thickness required for design, the areas  $A_1$  and  $A_2$  should be evaluated as separate anomalies. If the circumferential separation distance is less than 6 times the wall thickness, the composite area ( $A_1 + A_2 - A_3$ ) and the overall length,  $L$ , should be used.

(2) *Type II Interaction (see Figure 451.6.2.2-2).* If the axial separation distance,  $L_3$ , is greater than or equal to 1 in. (25.4 mm), the areas  $A_1$  and  $A_2$  should be evaluated as separate anomalies. If the axial separation distance is less than 1 in. (25.4 mm), area  $A_1$  plus  $A_2$  should be used and the length,  $L$ , should be taken as  $L_1 + L_2 + L_3$ .

(e) *Grooving, Selective, or Preferential Corrosion of Welds.* Grooving, selective, or preferential corrosion of the longitudinal seam of any pipe manufactured by the electric resistance welding (ERW) process, electric induction welding process, or electric flash welding process shall be removed or repaired.

**451.6.2.3 Gouges, Grooves, and Arc Burns.** Gouges and grooves shall be evaluated by nondestructive examination. Superficial grinding may be necessary to provide a smooth surface for nondestructive examination. The remaining wall thickness after grinding shall not be less than the minimum permitted by the component specification. Upon completion of superficial grinding, the absence of any cracking shall be confirmed by using dye-penetrant or magnetic-particle inspection. If no cracking is present, the net remaining wall thickness shall be determined by ultrasonic measurement. Gouges and grooves that leave less than the minimum wall thickness permitted by the component specification shall be removed or evaluated for repair in accordance with para. 451.6.2.2(b).

Arc burns shall be removed or repaired by grinding. Arc burns repaired by grinding shall be etched to confirm removal of all of the metallurgically altered material. Suitable etchants include 10% nital or 20% ammonium persulfate. All dark-etching material shall be removed, and the remaining wall thickness shall be determined by ultrasonic measurement.

**451.6.2.4 Dents.** Dents exposed for examination that have any of the following characteristics shall be removed or repaired unless an engineering evaluation can demonstrate that other mitigative action as defined in API 1160 will reduce the risk to an acceptable level:

(a) dents containing gouges, grooving, scratches, cracking, or other stress riser



Figure 451.6.2.2-1 Type I Interaction

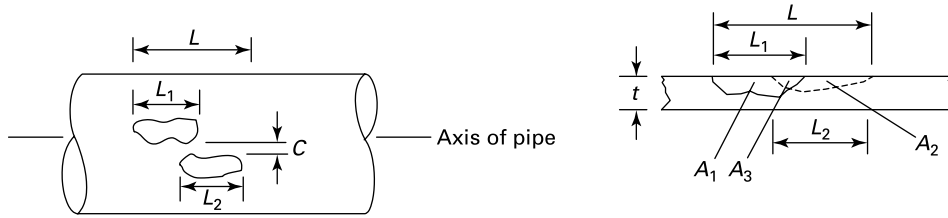
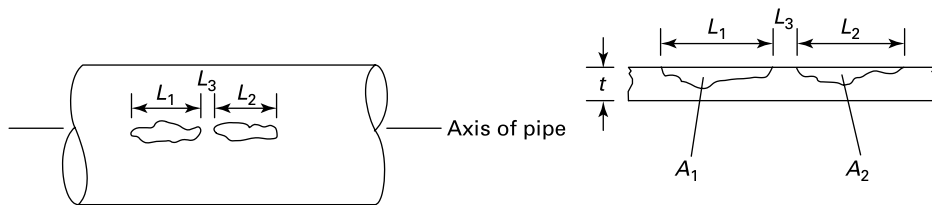


Figure 451.6.2.2-2 Type II Interaction



(b) dents containing metal loss resulting from corrosion or grinding where less than the minimum wall thickness permitted by the component specification remains

(c) dents that affect pipe curvature at a girth weld or a longitudinal seam weld

(d) dents with a depth greater than 6% of the nominal pipe diameter [0.250 in. (6.4 mm) in depth for a pipe diameter NPS 4 and smaller]

The absence of any cracks shall be confirmed by inspection using magnetic-particle or dye-penetrant techniques. Prior to inspection, the surface of the dent shall be cleaned to bare metal. Dents that could restrict the passage of ILI tools should be removed.

**451.6.2.5 Cracks.** Verified cracks except shallow crater cracks or star cracks in girth welds shall be considered defects and removed or repaired unless an engineering evaluation shows that they pose no risk to pipeline integrity. Shallow crater cracks or star cracks in girth welds,  $\frac{5}{32}$  in. (4.0 mm) or less in length, are not considered defects.

(19) **451.6.2.6 Anomalies Created by Manufacturing Processes.** An anomaly created during the manufacture of the steel or the pipe that exists in a pipeline that has been subjected to a hydrostatic test to a minimum level of 1.25 times its maximum operating pressure in accordance with para. 437.4.1 shall not be considered a defect unless the operator has reason to suspect that the anomaly has been enlarged by pressure-cycle-induced fatigue. If it is established that the anomaly has become or is likely to become enlarged by pressure-cycle-induced fatigue, the anomaly shall be removed or repaired, unless an engineering evaluation

indicates that the anomaly will not affect integrity before the next planned inspection.

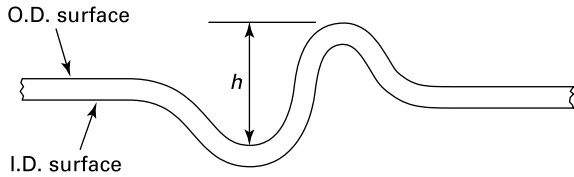
Suspected hard spots or flat spots should be examined by means of a hardness tester. Areas having a hardness level corresponding to Rockwell C 35 or more shall be removed or repaired.

A lamination that lies on a plane parallel to the pipe surfaces shall not be considered a defect unless it intersects a seam or girth weld or it extends to the inside or outside surface of the pipe. A lamination that intersects a girth weld or seam weld, that lies on a plane inclined to the plane of the pipe surfaces, or that extends to the inside or outside surface of the pipe shall be removed or repaired. Prior to repair, the entire extent of the lamination should be defined by means of ultrasonic measurement of the wall thickness. Laminations discovered as a result of ILI activities should be cross-referenced, if possible, to deformation data to examine the possibility that a lamination is actually a blister.

**451.6.2.7 Blisters.** Blisters shall be considered defects and shall be removed or repaired. Prior to repair, the entire extent of the blister should be defined by a nondestructive technique.

**451.6.2.8 Buckles, Ripples, Wrinkles.** For small ripples (i.e., incipient buckles or wrinkles) that exhibit no cracks, no repair is required if the crest-to-trough height,  $h$ , meets one of the following criteria where the maximum operating hoop stress,  $S$ , is as shown. The absence of any cracks shall be confirmed using magnetic-particle or dye-penetrant inspection.

Maximum Operating Hoop Stress, $S$	$\left(\frac{h}{D}\right) \times 100$ Cannot Exceed
$\leq 20,000$ psi (138 MPa)	2
$> 20,000$ psi (138 MPa), $\leq 30,000$ psi (207 MPa)	$\left(\frac{30,000 - S}{10,000} + 1\right)$
$> 30,000$ psi (207 MPa), $\leq 47,000$ psi (324 MPa)	$0.5 \left(\frac{47,000 - S}{17,000} + 1\right)$
$> 47,000$ psi (324 MPa)	0.5



where

- $D$  = outside diameter of the pipe, in. (mm)
- $h$  = crest-to-trough height of the ripple, in. (mm)
- $S$  = maximum operating hoop stress, psi (145S, MPa)

When a group of buckles, ripples, or wrinkles exist in proximity to one another, the limitation on  $h$  shall be applied to the largest crest-to-trough height.

- (19) **451.6.2.9 Permanent Repairs.** Defects may be removed or repaired by one or more of the methods described below subject to the limitations listed for each type of defect and repair method (see [Tables 451.6.2.9-1](#) and [451.6.2.9-2](#) for some acceptable methods). Other methods can be used, provided they are supported by sound engineering principles and meet the requirements of this Code.

(a) *Removal.* The section of pipe containing the defect should be removed as a cylinder and replaced. The replacement pipe shall meet the requirements of [para. 401.2.2](#) and, where possible, should have a length not less than one-half the diameter or not less than 3 in. (76.2 mm), whichever is greater. The pipeline should be uncovered or otherwise relaxed from restraint over a sufficient distance to allow a reasonably stress-free realignment.

(b) *Grinding.* Defects may be removed by grinding within the limitations stated below. Prior to grinding, limits on grinding imposed by the operating pressure, the remaining wall thickness, and the proximity of defects should be considered. The ground area should have a smooth transition (minimum 4-to-1 slope) between it and the surrounding pipe. See ASME PCC-2, Article 3.4 for more information on grind repairs. Weld imperfections, arc burns, gouges, grooves, and cracks may be removed by grinding prior to any additional

repairs. Dents with stress risers may be ground to remove the stress riser prior to installation of a repair.

Grinding of defects shall include

(1) confirmation of complete removal of the defect by using visual and magnetic-particle or dye-penetrant inspection

(2) measurement of longitudinal length and remaining wall thickness of the ground area using mechanical or ultrasonic measurement equipment to ensure compliance with an appropriate fitness-for-purpose criterion

Ground arc burns must be etched in accordance with [para. 451.6.2.3](#) to confirm removal of all of the metallurgically altered material.

Areas where grinding reduces the remaining wall thickness to less than the design thickness calculated in accordance with [para. 403.2](#), decreased by an amount equal to the manufacturing tolerance applicable to the pipe or component, should be analyzed using an appropriate fitness-for-purpose criterion [see [para. 451.6.2.2\(b\)](#)]. The remaining wall thickness after grinding shall not be less than 60% of the nominal wall thickness of the pipe.

If grinding is to be the sole means of repair of a dent containing cracks or other stress risers, the cracks, stress risers, or other defects shall be completely removed and the remaining wall thickness after grinding shall not be less than the minimum wall thickness as permitted by the component specification, which shall be confirmed by ultrasonic measurement methods.

(c) *Deposited Weld Metal.* Defects in welds produced with a filler metal, small corroded areas, gouges, grooves, and arc burns may be repaired by depositing weld metal, provided that they are not located within the confines of an indented region of the pipe. The welding processes shall be in accordance with the appropriate pipe specification for the grade and type of pipe being repaired. Weld imperfections, arc burns, gouges, and grooves shall be removed by grinding prior to depositing the weld filler metal. The qualification test for welding procedures to be used on pipe containing a liquid shall include the cooling effects of the pipe contents on the soundness and physical properties of the weld. Welding procedures on pipe not containing liquid shall be qualified in accordance with [para. 434.8.3](#). A welding procedure specification for repairing by means of deposited weld metal shall be established. The welding procedure specification shall define the minimum allowable remaining wall thickness in areas where weld deposition is to be used and the appropriate value of pressure in the carrier pipe during this type of repair. Low-hydrogen electrodes shall be used to prevent hydrogen cracking in carbon steel materials.

(d) *Full-Encirclement Sleeves.* Repairs may be made by the installation of a full-encirclement-welded split sleeve. See ASME PCC-2, Article 2.6 for more information on steel repair sleeves. Sleeve configurations may be one of the following:

(1) *Non-Pressure-Containing Sleeve Configuration (Type A)*. For full-encirclement split sleeves installed for repair by reinforcement only and not internal pressure containment, circumferential welding of the ends is not allowed. A hardenable filler material such as non-shrink epoxy shall be used to fill any voids that exist between the sleeve and the defective area being repaired. The ends of the sleeve shall extend past the edge of the defect for a minimum of 2 in. (50 mm). When a reinforcing sleeve is used for defects with length less than  $L$ , as defined in the following equation, the thickness of the sleeve material may be a minimum of two-thirds that of the carrier pipe. For flaws with length greater than  $L$ , the thickness of the sleeve material must be equal to or greater than that of the carrier pipe.

$$L = 20 \times \sqrt{D \times t}$$

where

$D$  = piped diameter

$t$  = wall thickness

When a Type A sleeve is used, measures shall be taken to prevent migration of water into space between the pipe and the sleeve. Electrical continuity shall be established between the pipe and the sleeve in order to provide cathodic protection. Type A sleeves should not be used to repair leaking defects or for circumferentially oriented defects.

A Type A sleeve may be installed in a manner that reduces the hoop stress in the carrier pipe. Methods for accomplishing this include lowering the pressure before the sleeve is installed, applying external mechanical force, or preheating the sleeve to facilitate a “shrink-fit.”

(2) *Pressure-Containing Sleeve Configuration (Type B)*. Type B sleeves shall have a design pressure not less than that of the pipe being repaired. The longitudinal seams of the sleeve shall be full-penetration butt welds. The ends of the sleeve shall be fillet-welded to the carrier pipe using a low-hydrogen welding procedure. The ends of the sleeve shall extend past the edge of the defect for a minimum of 2 in. (50 mm). If the sleeve is thicker than the pipe being repaired, the circumferential ends should be chamfered (at approximately 45 deg) down to the thickness of the pipe or the leg length of the fillet weld on the end of the sleeve should not be allowed to exceed the thickness of the carrier pipe by more than  $\frac{1}{16}$  in. (1.6 mm). Also, the leg length of the fillet weld on the end of the sleeve should not be less than the thickness of the carrier pipe minus  $\frac{1}{16}$  in. (1.6 mm). Special consideration shall be given to minimize stress concentration resulting from the repair.

Type B sleeves may be used for leaking or nonleaking defects including circumferentially oriented defects. When multiple sleeves are used, a Type B sleeve should not be terminated within one-half of a pipe

diameter or 4 in. from a girth weld, whichever is greater. The distance between sleeves should be at least one pipe diameter. Separated sleeves may be spaced less than one pipe diameter apart if joined by a welded bridging sleeve or made continuous by butt-welding them together. When installed at a nonleaking defect, a Type B sleeve may be installed in a manner that reduces the hoop stress in the carrier pipe. Methods for accomplishing this include lowering the pressure before the sleeve is installed, applying external mechanical force, or preheating the sleeve to facilitate a “shrink-fit.”

(e) *Composite Sleeve*. Nonleaking corroded areas and certain other types of defects may be repaired by the installation of a composite sleeve, provided that design and installation methods are proven for the intended service prior to application. A qualified written procedure performed by trained personnel is required, and records shall be retained in accordance with [section 455](#). A composite sleeve must have been tested to determine if it is compatible with cathodic protection and the product in the carrier pipe. The composite sleeve must also retain its essential properties in a moist environment at temperatures within the operational temperature range of the pipe. The load-carrying capacity of the remaining pipe and the composite sleeve shall be at a minimum equal to the nominal load-carrying capacity of the pipe. Composite sleeves should be marked and/or documented as to location so that it will be evident that a repair has been made at the specific location.

Composite sleeves shall not be used to repair leaks, metal loss with a depth greater than 80% of the nominal wall thickness, cracks, or circumferentially oriented defects.

Composite sleeves may be used to repair defects that have been removed by grinding.

(f) *Mechanical Bolt-On Clamp*. Repairs may be made to both leaking and nonleaking defects by the installation of a mechanically applied clamp. A mechanical clamp shall have a design pressure not less than that of the pipe being repaired. Mechanical clamps shall not be used to repair circumferentially oriented defects unless designed to withstand the axial load. A mechanical clamp may be fully welded, both circumferentially and longitudinally and seal welded at the bolts. The clamp ends shall extend past the edges of the defect for a minimum of 2 in. (50 mm). Mechanically applied full-encirclement repair fittings shall meet the design requirements of [para. 401.2](#).

(g) *Hot Tapping*. Defects may be removed by hot tapping. When hot tapping is used as a means of repair, the portion of piping containing the defect shall be completely removed. Hot tap fittings larger than 2 in. (50 mm) that have integral material sufficient to satisfy the area replacement requirements of [para. 404.3.5](#) may not have adequate resistance to external



forces and moments if used without full-encirclement reinforcement.

(h) *Fittings*. Minor leaks resulting from external corrosion and small externally corroded areas may be repaired by the installation of a welded fitting. Welded fittings used to cover pipeline defects shall not exceed NPS 3 and shall have a design pressure not less than that of the pipe being repaired. Pipe containing arc burns, grooves, and gouges may be repaired with a welded fitting if the arc burn or stress riser associated with the gouge or groove is removed by grinding. No crack shall be repaired by this method.

(i) *Patches and Half Soles*. Neither patches nor half soles shall be installed on pipelines.

**451.6.2.10 Temporary Repairs.** Temporary repairs may be necessitated for operating purposes. Such temporary repairs shall be made in a safe manner and in accordance with sound engineering principles. Temporary repairs shall be made permanent or replaced in a permanent manner as soon as practical in accordance with this Code.

**451.6.3 Testing Repairs to Pipelines Operating at a Hoop Stress of More Than 20% of the Specified Minimum Yield Strength of the Pipe.** When a scheduled repair to a pipeline is made by cutting out a section of the pipe as a cylinder and replacing it with another section of pipe, the replacement section of pipe shall be subjected to a pressure test. The replacement section of pipe shall be tested as required for a new pipeline in accordance with [para. 437.4.1](#). The tests may be made on the pipe prior to installation, provided radiographic or other acceptable nondestructive tests (visual inspection excepted) are made on all tie-in butt welds after installation.

## 451.8 Valve Maintenance

Pipeline block valves shall be inspected, serviced where necessary, and partially operated at least once each year to ensure proper operating conditions.

## (19) 451.9 Railroads and Highways Crossing Existing Pipelines

(a) When an existing pipeline is to be crossed by a new road or railroad, the operating company shall analyze the pipeline in the area to be crossed in terms of the new anticipated external loads in accordance with [para. 402.8](#). If existing pipeline stresses exceed the allowable stress requirement of [para. 403.8.6](#), the operating company shall install mechanical reinforcement, structural protection, or suitable pipe to reduce the stress to  $0.90S_y$  or less, or redistribute the external loads acting on the pipeline. API RP 1102 provides methods that may be used to determine the total stress caused by internal pressure and external loads. API RP 1102

also provides methods to check cyclic stress components for fatigue.

(b) Installation of uncased carrier pipe is preferred. Adjustments of existing pipelines in service at a proposed railroad or highway crossing shall conform to details contained in API RP 1102. As specified in [para. 461.1.7](#), if casing is used, coated carrier pipe shall be independently supported outside each end of the casing and insulated from the casing throughout the cased section, and casing ends shall be sealed using a durable, electrically nonconductive material.

(c) Testing and inspection of replaced pipe sections shall conform to requirements of [para. 451.6.3](#). All new girth welds in the carrier pipe shall be radiographed or inspected by other acceptable nondestructive methods (visual inspection excepted).

## 451.10 Inland Waters Platform Risers

Riser installations shall be visually inspected annually for physical damage and corrosion in the splash zone and above. The extent of any observed damage shall be determined, and, if necessary, the riser installation shall be repaired or replaced.

## 451.11 Leak Detection

While in operation, all pipe segments should be periodically monitored to ensure they are not leaking. On-site personnel, both as neighbors of the pipeline system and as operator employees, discover many leaks. Operators should continue to communicate and maintain the detection and response skills necessary to support visual inspection of the pipeline system. In addition, operators should consider supplemental leak detection methods other than visual.

Selection and implementation of the leak detection system should take into account the risk of both the likelihood and consequence of a leak. Some factors that could reduce the risk when an operator is determining the type and frequency of monitoring to employ include the following:

(a) service — clean, noncorrosive, low vapor pressure liquids

(b) location — away from population, on operator-controlled property, away from areas that would suffer irreparable damage, not near waterways supporting recreational or commercial traffic

(c) construction — material operating well below threshold limits

(d) operating at low stress levels

(e) leak history — indicates years with no leaks

Response time expected during a leak or emergency is another important factor that should be considered. Longer response time supports the benefit of faster detection needs. Accuracy of detection and lack of false indications are also factors that support or diminish the reliability of the leak detection method selected.

**Table 451.6.2.9-1 Acceptable Pipeline Repair Methods (Nonindented, Nonwrinkled, and Nonbuckled Pipe)**

Type of Defect	Repair Methods								
	1 Replace as Cylinder	2 Removal by Grinding	3 Deposition of Weld Metal	4a		5 Composite Sleeve	6 Mechanical Bolt-On Clamps	7 Hot Tap	8 Fittings
				Reinforcing Full- Encirclement Sleeve (Type A)	Pressure- Containing Full- Encirclement Sleeve (Type B)				
External corrosion $\leq 80\% t$ (excluding grooving, selective, or preferential corrosion of ERW, EFW seams)	Yes [Note (1)]	No	Limited [Note (2)]	Limited [Note (3)]	Yes	Yes [Note (3)]	Yes	Limited [Note (4)]	Limited [Note (5)]
External corrosion $> 80\% t$	Yes [Note (1)]	No	No	No	Yes	No	Yes	Limited [Note (4)]	Limited [Note (5)]
Internal corrosion $\leq 80\% t$	Yes [Note (1)]	No	No	Limited [Note (6)]	Yes	Limited [Note (6)]	Yes	Limited [Note (4)]	No
Internal corrosion $> 80\% t$	Yes [Note (1)]	No	No	No	Yes	No	Yes	Limited [Note (4)]	No
Grooving, selective or preferential corrosion of ERW, EFW seam	Yes [Note (1)]	No	No	No	Yes	No	Yes	Limited [Note (4)]	No
Gouge, groove, or arc burn	Yes [Note (1)]	Limited [Note (7)]	Limited [Notes (2), (7)]	Limited [Notes (3), (8)]	Yes	Limited [Notes (3), (8)]	Yes	Limited [Note (4)]	Limited [Notes (5), (8)]
Crack	Yes [Note (1)]	Limited [Note (7)]	No	Limited [Note (7)]	Yes	Limited [Note (7)]	Yes	Limited [Note (4)]	No
Hard spot	Yes [Note (1)]	No	No	Limited [Note (3)]	Yes	No	Yes	Limited [Note (4)]	No
Blisters	Yes [Note (1)]	No	No	No	Yes	No	Yes	Limited [Note (4)]	No
Defective girth weld	Yes [Note (1)]	No	Limited [Note (2)]	No	Yes	No	Yes	No	No
Lamination	Yes [Note (1)]	No	No	No	Yes	No	Yes	No	No

**NOTES:**

- (1) Replacement pipe should have a minimum length of one-half of its diameter or 3 in. (76.2 mm), whichever is greater, and shall meet or exceed the same design requirements as those of the carrier pipe.
- (2) The welding procedure specification shall define minimum remaining wall thickness in the area to be repaired and maximum level of internal pressure during repair. Low-hydrogen welding process must be used.
- (3) Tight-fitting sleeve at area of defect must be ensured or a hardenable filler such as epoxy or polyester resin shall be used to fill the void or annular space between the pipe and the repair sleeve.
- (4) Defect must be contained entirely within the area of the largest possible coupon of material that can be removed through the hot-tap fitting.
- (5) The defect shall be contained entirely within the fitting and the fitting size shall not exceed NPS 3.
- (6) May be used only if internal corrosion is successfully mitigated.
- (7) Gouge, groove, arc burn, or crack must be entirely removed without penetrating more than 40% of the wall thickness. The allowable length of metal removal is to be determined by para. 451.6.2.2(a). Removal of gouge, groove, arc burn, or crack must be verified by visual and magnetic-particle or dye-penetrant inspection (plus etchant in the case of arc burns).
- (8) May be used only if gouge, groove, arc burn, or crack is entirely removed and removal is verified by visual and magnetic-particle or dye-penetrant inspection (plus etchant in the case of arc burns).

**Table 451.6.2.9-2 Acceptable Pipeline Repair Methods for Dents, Buckles, Ripples, Wrinkles, Leaking Couplings, and Defective Prior Repairs**

Type of Defect	Repair Methods					
	1 Replace as Cylinder	2 Removal by Grinding	4a Reinforcing-Type Full- Encirclement Sleeve (Type A)	4b Pressure- Containing Full- Encirclement Sleeve (Type B)	5 Composite Sleeve	6 Mechanical Bolt-On Clamps
Dents ≤6% of the diameter of the pipe containing seam or girth weld	Yes [Note (1)]	No	Limited [Note (2)]	Yes	Limited [Note (2)]	Yes
Dents ≤6% of the diameter of the pipe containing gouge, groove, or crack	Yes [Note (1)]	Limited [Note (3)]	Limited [Notes (2), (4)]	Yes	Limited [Notes (2), (4)]	Yes
Dents ≤6% of the diameter of the pipe containing external corrosion with depth exceeding 12½% of wall thickness	Yes [Note (1)]	No	Limited [Note (2)]	Yes	Limited [Note (2)]	Yes
Dent exceeding 6% of the diameter of pipe	Yes [Note (1)]	No	Limited [Note (2)]	Yes	Limited [Notes (2), (4)]	Yes
Buckles, ripples, or wrinkles	Yes [Note (1)]	No	Limited [Note (2)]	Yes	No	Yes
Leaking coupling	Yes [Note (1)]	No	No	Yes	No	Yes
Defective sleeve from prior repair	Yes [Note (1)]	No	No	Yes	No	Yes

NOTES:

- (1) Replacement pipe should have a minimum length of one-half of its diameter or 3 in. (76.2 mm), whichever is greater, and shall meet the same design requirements as those of the carrier pipe.
- (2) A hardenable filler such as epoxy or polyester resin shall be used to fill the void between the pipe and the repair sleeve.
- (3) May be used only if the crack, stress riser, or other defect is entirely removed, removal is verified by visual and magnetic-particle or dye-penetrant inspection (plus etchant in the case of arc burns), and the remaining wall thickness is not less than the minimum wall thickness as permitted by the component specification.
- (4) May be used only if gouge, groove, arc burn, or crack is entirely removed and removal is verified by visual and magnetic-particle or dye-penetrant inspection (plus etchant in the case of arc burns).

The operator should carefully select leak detection systems. The detection system can consist of regularly scheduled right-of-way patrol, aerial, land, or water; analysis of blocked-in pressures; monitoring changes of flow or pressure from steady-state operation; volumetric line balances; pressure wave analysis, or any other method capable of detecting leakage in a timely manner. Monitoring intervals vary from continuous with computerized evaluation software, to range from weekly to daily for visual observation methods. If computer-based monitoring is utilized, API RP 1130 should be followed.

Whatever method is selected, operators should monitor and analyze their leak performance periodically and make adjustments to the leak detection method selected to reduce the leakage.

**451.12 Strain Criteria for Existing Pipelines**

When an existing pipeline experiences a noncyclic displacement of its support (such as fault movement along the pipeline route or differential support settlement or subsidence along the pipeline), the longitudinal and combined stress limits may be replaced with an allowable strain limit, so long as the consequences of yielding do not impair the serviceability of the installed pipeline. This allowable strain limitation does not apply to localized strains such as those found in dents, field bends, or induction bends. The permissible maximum tensile strain depends on the ductility of the material, any previously experienced plastic strain, and the buckling behavior of the pipe. Where plastic strains are anticipated, the pipe eccentricity, pipe out-of-roundness, and the ability of the welds to undergo such strains without detrimental effect shall be considered. Maximum tensile strain shall be limited to 2%.

## 452 PUMP STATION, TERMINAL, AND STORAGE FACILITIES OPERATION AND MAINTENANCE

### 452.1 General

(a) Starting, operating, and shutdown procedures for all equipment shall be established and the operating company shall take appropriate steps to see that these procedures are followed. These procedures shall outline preventive measures and systems checks required to ensure the proper functioning of all shutdown, control, and alarm equipment.

(b) Pipeline equipment located on operator property should be monitored regularly for indications of leaks. The operator should evaluate the alternatives available, giving consideration to the following:

(1) monitoring systems such as gas detectors, sump-level alarms, pump seal failure alarms, and high-level alarms of tanks and storage vessels

(2) observation patrols or operational checks conducted on an hourly, daily, weekly, or monthly schedule appropriate for the location's factors

(3) periodic static pressure tests of piping and storage tanks

(4) careful evaluation of routine operating volumetric receipt, delivery, and inventory reports

(5) fugitive emission testing of seal and glands

(6) public awareness programs to enhance recognition and response to leaks, etc.

A periodic review and analysis of leaks that have occurred on the operator's property should be conducted to identify corrective actions.

### 452.2 Controls and Protective Equipment

(a) Controls and protective equipment, including pressure-limiting devices, regulators, controllers, relief valves, and other safety devices, shall be subjected to systematic periodic inspections and tests, at least annually, except as provided in (b), to determine that they are

(1) in good mechanical condition

(2) adequate from the standpoint of capacity and reliability of operation for the service in which they are employed

(3) set to function at the correct pressure

(4) properly installed and protected from foreign materials or other conditions that might prevent proper operation

(b) Relief valves on pressure storage vessels containing LPG or liquid anhydrous ammonia shall be subjected to tests at least every 5 yr.

### 452.3 Storage Facilities

(a) Storage facilities, including atmospheric and pressure tanks, handling the liquid or slurry being transported shall be periodically inspected and pertinent records maintained. Points to be covered include

(1) stability of foundation

(2) condition of bottom, shell, stairs, and roof

(3) venting or safety valve equipment

(4) condition of firewalls or tank dikes

(b) Storage vessels and tanks shall be cleaned in accordance with API 2015.

### 452.4 Storage of Combustible Materials

All flammable or combustible materials in quantities beyond those required for everyday use or other than those normally used in pump houses shall be stored in a separate structure built of noncombustible material located a suitable distance from the pump house. All aboveground oil or gasoline storage tanks shall be protected in accordance with NFPA 30.

### 452.5 Fencing

Station, terminal, and storage areas shall be maintained in a safe condition, and shall be fenced and locked, or attended, for the protection of the property and the public.

### 452.6 Signs

(a) Suitable signs shall be posted to serve as warnings in hazardous areas.

(b) Classified and high-voltage areas shall be adequately marked and isolated.

(c) Caution signs shall be displayed indicating name of the operating company and, where possible, an emergency telephone contact.

### 452.7 Prevention of Accidental Ignition

(19)

(a) Smoking shall be prohibited in all areas of a pump station, terminal, or tank farm in which the possible leakage or presence of vapor constitutes a hazard of fire or explosion.

(b) Flashlights or hand lanterns, when used, shall be of the approved type.

(c) Welding shall commence only after compliance with para. 434.8.1(c).

(d) Consideration should be given to the prevention of other means of accidental ignition. See NACE SP 0177 for additional guidance.

## 453 CORROSION CONTROL

Protection of ferrous pipe and components from external and internal corrosion, including tests, inspections, and appropriate corrective measures, shall be as prescribed in Chapter VIII.

## 454 EMERGENCY PLAN

(a) A written emergency plan shall be established for implementation in the event of system failures, accidents, or other emergencies, and shall include procedures for

prompt and expedient remedial action providing for the safety of the public and operating company personnel, minimizing property damage, protecting the environment, and limiting accidental discharge from the piping system.

(b) The plan shall provide for training of personnel responsible for the prompt execution of emergency action. Personnel shall be informed concerning the characteristics of the liquid or slurry in the piping systems and the safe practices in the handling of accidental discharge and repair of the facilities, with emphasis on the special problems and additional precautions in the handling of leaks and repair of systems transporting LPG, slurry, or liquid anhydrous ammonia. The operating company shall establish scheduled reviews with personnel of procedures to be followed in emergencies at intervals not exceeding 6 months, and reviews shall be conducted such that they establish the competence of the emergency plan.

(c) Procedures shall cover liaison with state and local civil agencies such as fire departments, police departments, sheriff's offices, highway patrols, and other entities in or near the pipeline right-of-way (e.g., electrical and other utilities, highway authorities, and railroads) to provide prompt intercommunications for coordinated remedial action; dissemination of information on location of system facilities; characteristics of the liquids or slurries transported, including additional precautions necessary with leaks from piping systems transporting LPG or liquid anhydrous ammonia; and joint preparation of cooperative action as necessary to ensure the safety of the public in the event of emergencies.

(d) A line of communications shall be established with residents along the piping system to recognize and report a system emergency to the appropriate operating company personnel. This could include supplying a card, sticker, or equivalent with names, addresses, and telephone numbers of operating company personnel to be contacted.

(e) In the formulation of emergency procedures for limiting accidental discharge from the piping system, the operating company shall give consideration to

(1) formulating and placing in operation procedures for an area cooperative pipeline leak notification emergency action system between operating companies having piping systems in the area

(2) reduction of pipeline pressure by ceasing pumping operations on the piping system, opening the system to delivery storage on either side of the leak site, and expeditious closing of block valves on both sides of the leak site, and in the case of systems transporting LPG, continuation of pumping until LPG has been replaced at point of leak by a less volatile product if vapors are not accumulating to an extent that a serious hazard appears imminent

(3) interim instructions to local authorities prior to arrival of qualified operating company personnel at the leak site

(4) rapid transportation of qualified personnel to the leak site

(5) minimization of public exposure to injury and prevention of accidental ignition by evacuation of residents and the halting of traffic on roads, highways, and railroads in the affected area

(6) in the case of systems transporting LPG, assessment of extent and coverage of the LPG vapor cloud and determination of hazardous area with portable explosimeters; ignition of vapors at leak site to prevent the uncontrolled spread of vapors; utilization of temporary flares or blowdowns on either side of the leak site; and utilization of internal plugging equipment where it is anticipated that vaporization of LPG entrapped in the pipeline segment will continue over a prolonged period

(7) in the case of systems transporting liquid anhydrous ammonia, assessment of the extent and coverage of the ammonia vapor cloud and utilization of internal plugging equipment where it is anticipated that vaporization of liquid anhydrous ammonia entrapped in the pipeline segment will continue over a prolonged period

## 455 RECORDS

For operation and maintenance purposes, the following records shall be properly maintained:

(a) necessary operational data

(b) pipeline patrol records

(c) corrosion records as required under [section 468](#)

(d) leak and break records

(e) records pertaining to routine or unusual inspections, such as external or internal line conditions

(f) pipeline repair records

## 456 QUALIFYING A PIPING SYSTEM FOR A HIGHER OPERATING PRESSURE

(a) In the event of up-rating an existing piping system when the higher operating pressure will produce a hoop stress of more than 20% of the specified minimum yield strength of the pipe, the following investigative and corrective measures shall be taken:

(1) the design and previous testing of the piping system and the materials and equipment in it be reviewed to determine that the proposed increase in maximum steady-state operating pressure is safe and in general agreement with the requirements of this Code

(2) the conditions of the piping system be determined by leakage surveys and other field inspections, examination of maintenance and corrosion control records, or other suitable means

(3) repairs, replacements, or alterations in the piping system disclosed to be necessary by (1) and (2) above be made



(b) The maximum steady-state operating pressure may be increased after compliance with (a) and one of the following provisions:

(1) If the physical condition of the piping system as determined by (a) indicates that the system is capable of withstanding the desired increased maximum steady-state operating pressure in accordance with the design requirement of this Code, and the system has previously been tested for a duration and to a pressure equal to or greater than required in paras. 437.4.1(a) and 437.4.1(c) for a new piping system for the proposed higher maximum steady-state operating pressure, the system may be operated at the increased maximum steady-state operating pressure.

(2) If the physical condition of the piping system as determined by (a) indicates that the ability of the system to withstand the increased maximum steady-state operating pressure has not been satisfactorily verified, or the system has not been previously tested to the levels required by this Code for a new piping system for the proposed higher maximum steady-state operating pressure, the system may be operated at the increased maximum steady-state operating pressure if the system shall successfully withstand the test required

by this Code for a new system to operate under the same conditions.

(c) In no case shall the maximum steady-state operating pressure of a piping system be raised to a value higher than the internal design pressure permitted by this Code for a new piping system constructed of the same materials. The rate of pressure increase to the higher maximum steady-state operating pressure should be gradual so as to allow sufficient time for periodic observations of the piping system.

(d) Records of such investigations, work performed, and pressure tests conducted shall be preserved as long as the facilities involved remain in service.

#### **457 ABANDONING A PIPING SYSTEM**

In the event of abandoning a piping system, it is required that

(a) facilities to be abandoned in place shall be disconnected from all sources of the transported liquid, such as other pipelines, meter stations, control lines, and other appurtenances

(b) facilities to be abandoned in place shall be purged of the transported liquid and vapor with an inert material and the ends sealed



## Chapter VIII

# Corrosion Control

### 460 GENERAL

(a) This Chapter contains the minimum requirements and procedures for controlling external and internal corrosion and erosion of exposed, buried, or submerged metallic pipe and components. This Chapter is applicable to the design and installation of new pipelines and associated piping systems and to the operation and maintenance of existing pipelines and associated piping systems.

(b) The provisions of this Chapter should be applied under the direction of competent corrosion personnel. Every specific situation cannot be anticipated; therefore, the application and evaluation of corrosion control practices require a significant amount of competent judgment in order to be effective in mitigating corrosion.

(c) Deviations from the provisions of this Chapter are permissible in specific situations, provided the operating company can demonstrate that the objectives expressed herein have been achieved.

(d) Corrosion control requirements and procedures may in many instances require measures in addition to those shown in this Chapter. Each operating company shall establish procedures to implement its corrosion control program, including the requirements of this Chapter, to achieve the desired objectives. Procedures, including those for design, installation, and maintenance of cathodic protection systems, shall be prepared and implemented by or under the direction of persons qualified by training or experience, or both, in corrosion control methods.

### 461 EXTERNAL CORROSION CONTROL FOR BURIED OR SUBMERGED PIPELINES

#### 461.1 New Installations

**461.1.1 General.** All new buried or submerged pipelines and associated terminal and pump station piping, except as permitted under [para. 461.1.3](#) and [section 466](#), shall be externally coated and cathodically protected unless it can be demonstrated by test or experience that the materials are resistant to corrosion in the environment in which they are installed. Consideration shall be given to the handling, shipping, storing, installation conditions, and the service environment and cathodic protection requirements when selecting the coating materials. The Corrosion Data Survey, published by the

National Association of Corrosion Engineers (NACE) International, is a source of information on materials performance in corrosive environments.

#### 461.1.2 Coating Requirements

(19)

(a) The surface preparation shall be compatible with the coating to be applied. The pipe surface shall be free of deleterious materials, such as rust, scale, moisture, dirt, oils, lacquers, and varnish. The surface shall be inspected for irregularities that could protrude through the coating. Any such irregularities shall be removed. Further information can be obtained from NACE/SSPC Joint Surface Preparation Standards.

(b) Suitable coatings, including compatible field joint and patch coatings, shall be selected, giving consideration to handling, shipping, storing, installation condition, moisture adsorption, operating temperatures of the pipeline, environmental factors (including the nature of the soil or water in contact with the coating), adhesion characteristics, and dielectric strength. Further information can be obtained from NACE Standards SP 0185, SP 0188, SP 0198, SP 0274, RP 0303, SP 0375, SP 0394, RP 0399, RP 0402, SP 0490, and RP 0602.

(c) Coatings shall be applied in a manner that ensures effective adhesion to the pipe. Voids, wrinkles, holidays, and gas entrapment should be avoided. In rocky environments, the use of a protective outer wrap, select backfill, or other suitable measures shall be considered to minimize physical damage to the coating.

Consideration should be given to providing an overcoating or other protection of coatings in storage that are susceptible to UV degradation.

(d) The coating shall be visually inspected for defects prior to lowering the pipe in the ditch. Insulating-type coatings on piping and pipelines shall be inspected for holidays by the most appropriate method. Coating defects or damage that may impair effective corrosion control shall be repaired before installing the pipe in the ditch. Further information can be obtained from NACE SP 0490.

(e) Care shall be exercised in handling, storage, and installation to prevent damage to the coating, including measures such as the following:

- (1) minimize handling of coated pipe
- (2) use equipment least likely to damage the coating, e.g., belts or cradles instead of cables

(3) use padded skids where appropriate

(4) stack or store pipe in a manner that prevents or minimizes damage to coating

**461.1.3 Cathodic Protection Requirements.** Unless it can be demonstrated by tests or experience that cathodic protection is not needed, all buried or submerged pipelines with barrier-type coatings, except facilities installed for a limited service life, shall be cathodically protected as soon as feasible following installation.

Pipelines installed for a limited service life need not be cathodically protected if it can be demonstrated that the pipeline will not experience corrosion that will cause it to be harmful to the public or environment. Cathodic protection systems shall be designed to protect the buried or submerged pipeline in its entirety. A pipeline is considered to be cathodically protected when it meets one or more of the criteria listed in Section 6, Criteria and Other Considerations for Cathodic Protection, of NACE SP 0169-2007.

#### 461.1.4 Electrical Isolation

**461.1.4.1 Foreign Structures.** All coated pipeline and piping systems shall be electrically isolated at all interconnections with foreign systems, except where underground metallic structures are electrically interconnected and cathodically protected as a unit. Steel pipelines shall be electrically isolated from cast iron, ductile iron, or nonferrous metal pipelines and components. Electrical tests shall be made of pipeline and piping systems to locate unintentional contacts with other metallic structures. If such contacts exist, they shall be corrected. Further information can be obtained from NACE SP 0286.

**461.1.4.2 Electric Transmission Lines.** Where a pipeline parallels overhead electric transmission lines, consideration shall be given to

(a) investigating the necessity of protecting isolating joints in the pipeline against induced voltages resulting from ground faults and lightning. Such protection can be obtained by

(1) grounding in the affected area with galvanic or impressed current anode material or with bare grounding cable

(2) bridging the pipeline insulator with a spark gap

(3) combinations of (1) and (2) above

(4) other sound engineering practices

(b) making a study in collaboration with the electric company, taking the following factors into consideration and applying remedial measures as appropriate:

(1) the need to mitigate induced AC voltages or their effects on personnel safety during construction and operation of the pipeline by means of suitable design for bonding, shielding, or grounding techniques

(2) the possibility of lightning or fault currents inducing voltages sufficient to puncture pipe coatings or pipe

(3) possible adverse effects on cathodic protection, communications, or other electronic facilities

(4) the corrosive effects of high-voltage direct current (HVDC) power systems

(c) Further information may be obtained from NACE SP 0177 and EPRI EL-3106.

**461.1.4.3 Transported Products.** Where a pipeline transports a product that is or contains an electrolyte, the use of internally lined isolating spools shall be considered. If used, the isolating pipe spools shall be designed to prevent ionic current resulting inside the pipeline between different pipeline steel potentials.

#### 461.1.5 Electrical Connections and Monitoring Points

(a) Except for offshore pipelines and piping systems, sufficient test points should be installed to demonstrate the effectiveness of corrosion control or the need for cathodic protection.

(b) Special attention shall be given to the manner of installation of electrical leads used for corrosion control or testing to avoid harmful stress concentration at the point of attachment to the pipe. Acceptable methods include, but are not limited to

(1) electrical leads attached directly to the pipe by the thermite welding process, using copper oxide and aluminum powder. The size of the thermite welding charge should be selected based on the wall thickness, operating pressure, and thermite welding equipment manufacturer's recommendations.

(2) attachment of electrical leads directly to the pipe by the use of soft solders or other methods that do not involve temperatures exceeding those for soft solders.

(c) All pipe that is bared for electrical lead connections and all bared electrical lead wires shall be protected by electrical insulating material compatible with existing coating.

#### 461.1.6 Electrical Interference

(a) Impressed current cathodic protection systems shall be designed, installed, and operated so as to minimize adverse effects on existing metallic structures.

(b) Field tests shall be conducted to determine the adverse electrical interference from foreign cathodic protection installations, DC rail, and electrical facilities. The effects shall be mitigated by such means as control bonds, supplementary cathodic protection, protective coatings, insulating devices, galvanic anodes, or other acceptable methods determined by sound engineering practice.

**461.1.7 Casings.** The use of metallic casings should be avoided insofar as possible from a corrosion control standpoint. However, it is recognized that installation of metallic casings is frequently required or desirable to facilitate construction. Where metallic casing is used, care shall be exercised to ensure that coating on the carrier pipe is not damaged during installation. The carrier pipe should be insulated from metallic (19)

casings, and the casing ends shall be sealed with a durable material to minimize the accumulation of solids and liquids in the annular space. Special attention shall be given to the casing ends to prevent electrical shorting due to backfilling movement or settling. Where electrical isolation is not achieved, action shall be taken to correct the condition by clearing the short if possible, by mitigating the potential for corrosion inside of the casing by installation of a high resistivity inhibited material in the annular space, by supplementing cathodic protection, or by other sound engineering practice. Further information can be obtained from NACE SP 0200.

## 461.2 Existing Buried or Submerged Steel Pipelines

**461.2.1 General.** Procedures shall be established for evaluating the need for a corrosion control program or the effectiveness of existing corrosion control programs, or both. Appropriate corrective action shall be taken commensurate with the conditions found. The procedures and actions shall include, but not be limited to, those listed in [para. 461.2](#).

### 461.2.2 Evaluation

(a) The records available as a result of visual and instrumented inspections, repairs, construction, and normal maintenance work shall be reviewed for evidence of continuing corrosion.

(b) Electrical survey methods may be used as an indication of suspected corrosive areas where surface conditions permit sufficiently accurate measurements. Such surveys are most effective in nonurban environments. Common survey methods include, but are not limited to, the following:

(1) pipe-to-soil potentials, including close interval surveys

(2) voltage gradient surveys

(3) soil resistivity

(c) The continued effectiveness of a cathodic protection system shall be monitored in accordance with [para. 461.2.7](#).

### 461.2.3 Corrective Measures

(a) If continuing corrosion that, unless controlled, could result in a condition that is detrimental to public or employee safety is found by the evaluation made under [para. 461.2.2](#) or [para. 461.2.7](#), appropriate corrective measures shall be taken to mitigate further corrosion on the pipeline segment or piping system. Corrective measures shall remain in effect as long as required to maintain a safe operating system. Appropriate corrective measures may include the following:

(1) provisions for proper and continuous operation of cathodic protection systems

(2) application of protective coating

(3) installation of galvanic anode(s)

(4) installation of impressed current systems

(5) electrical isolation

(6) stray current control

(7) other effective measures as determined by sound engineering practices

(8) combinations of the above

(b) When experience or testing indicates the above mitigation methods will not control continuing corrosion to an acceptable level, the segment shall be reconditioned or replaced and suitably protected in accordance with the new installation criteria in [para. 461.1](#).

### 461.2.4 Cathodic Protection Criteria

(a) A pipeline or structure is considered to be cathodically protected when it meets one or more of the criteria listed in Section 6, Criteria and Other Considerations for Cathodic Protection, of NACE SP 0169-2007.

(b) It is not intended that cathodic protection be limited to these criteria if it can be demonstrated by other sound engineering practice that adequate control of corrosion has been achieved.

### 461.2.5 Electrical Interference

(a) Adverse electrical interference from or to foreign structures as determined by field tests shall be mitigated.

(b) Facilities for mitigating electrical interference shall be periodically monitored.

### 461.2.6 Examination When Exposed

(a) Whenever a buried facility is exposed during normal maintenance or construction activities, a visual inspection shall be made of the coating condition and/or the metal surface.

(b) The extent of any corrosion shall be evaluated in accordance with [para. 461.2.4](#).

### 461.2.7 Tests and Inspections of Cathodic Protection System

(a) Inspections shall be made as required to maintain continuous and effective operation of the cathodic protection system.

(b) Electrical tests shall be made periodically to determine that the pipeline system is protected in accordance with the applicable criteria as established by this Code.

(c) The type, frequency, and location of inspections and tests shall be adequate to establish with reasonable accuracy the degree of protection provided. Tests may be required more frequently, depending on consideration of at least the following:

(1) condition of pipe

(2) method of cathodic protection

(3) corrosiveness of the environment

(4) probability of loss or interruption of protection

(5) operating experience, including inspections and leak investigations

(6) design life of the cathodic protection installation

(7) public and employee safety

(8) regulatory requirements

(d) Where the tests or surveys indicate that adequate protection does not exist, appropriate corrective measures shall be taken.

**461.2.8 Casings.** Electrical isolation of cathodically protected pipelines from metallic casings that are part of the underground system shall be maintained as necessary to ensure effectiveness of cathodic protection. Electrical measurements and inspections shall be made as necessary to provide timely evidence of shorts that would adversely affect cathodic protection. If evidence of shorts between the carrier pipe and casing is found that renders cathodic protection of the pipeline ineffective, or if evidence of corrosion of the carrier pipe inside the casing is found, remedial measures shall be taken as necessary to correct the condition or minimize corrosion inside the casing.

## 462 INTERNAL CORROSION CONTROL

### (19) 462.1 General

When a corrosive liquid is transported, provision shall be made to protect the piping system from detrimental corrosion. Hydrocarbons containing free water, under the conditions at which they will be transported, shall be assumed to be corrosive, unless proven to be noncorrosive by recognized tests or experience. Further information can be obtained from NACE SP 0192, TM 0172, and MR 0175/ISO 15156.

### (19) 462.2 New Installations

When designing a new or replacement pipeline system, or additions or modifications to existing systems, measures should be considered to prevent or inhibit internal corrosion, or both. To preserve the integrity and efficiency of a pipeline in which it is known or anticipated that a corrosive liquid will be transported, the following factors should be considered in the design and construction, either separately or in combination:

#### (a) Internal Coating

(1) The coating shall meet the quality specifications and the minimum dry film thickness established for the protection of the facility from the corrosive media involved, based on the type of coating and methods of application.

(2) Applied coatings shall be inspected in accordance with established specifications or accepted practice.

(3) When coated pipe or other components are joined by welding or other methods that leave the parent metal exposed, provision shall be made to

prevent joint corrosion, such as cleaning and recoating or the continuing use of a suitable inhibitor.

(4) If pigs or spheres are to be used, the types of coating and pitting tools used should be evaluated and chosen to prevent damage to the internal coating.

#### (b) Chemical Treatment

(1) The equipment for the holding, transfer, and injection of the chemical into the stream shall be included in the design.

(2) The operation of the injection program should be a part of the planning.

(3) Sufficient test coupon holders or other monitoring equipment shall be provided to allow for continued program evaluations.

(4) The chemical selected shall be of a type that will not cause deterioration of any components of the piping system.

#### (c) Cleaning Pigs

(1) Scraper traps for the insertion and removal of pigs or spheres, or both, shall be provided.

(2) Sections of pipeline to be traversed by pigs or spheres shall be designed to prevent damage to pigs, spheres, pipes, or fittings during operations.

(3) Piping for pigs or spheres shall be designed to guide the tool and the materials they propel effectively and safely.

(4) Provision shall be made for effective accumulation and handling of liquid and solid materials removed from the pipeline by pigs or spheres.

#### (d) Monitoring Devices

(1) Monitoring devices shall be installed where practical at locations where the greatest potential for internal corrosion exists.

(2) Monitoring devices must be designed to permit passage of pigs or spheres when installed in sections traversed thereby.

#### (e) Reducing Corrosivity

(1) Separators or dehydration equipment, or both, may be installed.

(2) Equipment for the removal of other deleterious material from the liquid should be considered.

#### (f) Materials

(1) Materials selected for pipe and fittings shall be compatible with the components of the liquid and with each other.

(2) Where plastic linings or alloy steel pipe and components are used to prevent or control internal corrosion, such materials shall have been determined to be effective under the anticipated operating environment and conditions to be encountered.

(3) Erosion-corrosion effects from high-velocity particles at probable points of turbulence and impingement should be minimized by use of erosion-resistant materials, added wall thickness, design or flow configuration, and size or dimensions of the pipe and fittings.

*(g) Erosion–Corrosion*

(1) It is usually necessary to control erosion–corrosion of liquid or slurry pipelines to mitigate premature failure of the line due to reduced wall thickness. Use of corrosion inhibitors and/or control of the pH, particle size, and flow velocity of the slurry or internal coating of the pipe may be used to limit erosion–corrosion of liquid or slurry pipelines. Other means of dealing with this effect, such as periodic replacement of components or the use of wear plates, are acceptable. See NACE MR 0175/ISO 15156 for guidance.

(2) If inhibitors are used, they shall be of a type that will not cause deterioration of any piping components and shall be used in sufficient quantity to mitigate internal corrosion.

(3) If internal coatings are used to control erosion–corrosion, they shall meet the quality specifications and minimum dry film thickness established in the industry and be inspected in accordance with industry recommended practices. On piping joined by welding or other methods exposing parent metal at the joints, internal coatings shall include provisions for joint protection such as the use of a suitable corrosion inhibitor.

(4) Wherever changes in flow direction or boundaries occur, such as bends, reducers, obstructions, or discontinuities, localized erosion–corrosion is possible. Means shall be provided to control local erosion–corrosion, such as piping geometry, velocity, particle size distribution, flow regime, wear plates, or other suitable means. Excessive weld penetration, high–low condition of a girth weld, sharp changes in direction, and eccentrically located gaskets should be avoided.

**(19) 462.3 Existing Installations**

A pipeline internal corrosion control program shall include, but not be limited to, the following:

(a) The establishment and evaluation of a program for the detection, prevention, or mitigation of detrimental internal corrosion should include the following:

(1) Pipeline leak and repair records should be reviewed for indication of the effects of internal corrosion.

(2) When any part of a pipeline is removed and the internal surface is accessible for inspection, it shall be visually examined and evaluated for internal corrosion. Additionally, visual examination shall be made for excessive weld penetration, high–low condition of a girth weld, and eccentrically located gaskets that should be avoided in a liquid or slurry pipeline.

(3) If evidence of internal corrosion is discovered, the liquid or slurry shall be analyzed to determine the types and concentrations of any corrosive agents.

(4) Liquids or solids removed from the pipeline by pigging, draining, or cleanup should be analyzed as necessary for determining the presence of corrosive materials and evidence of corrosion products.

(b) Where it is determined that internal corrosion is taking place that could affect public or employee safety, one or more of the following protective or corrective measures shall be used to control detrimental internal corrosion:

(1) An effective chemical treatment may be applied in a manner and quantity to protect all affected portions of the piping systems.

(2) Corrosive agents may be removed by recognized methods, such as dehydration.

(3) Fittings may be added for removal of water from low spots, or reposition piping to reduce hold-up water.

(4) Under some circumstances, application of a suitable internal coating may be effective.

(5) Components may be replaced, or wear plates may be used to control erosion–corrosion.

(6) The pipeline design or flow configuration may be modified. Sharp changes in direction should be avoided in liquid or slurry pipelines.

(7) Erosion–corrosion effects may be minimized by controlling the particle size.

(c) Internal corrosion control measures shall be evaluated by an inspection and monitoring program, including, but not limited to, the following:

(1) The chemical and the injection system should be periodically checked.

(2) Corrosion coupons and test spools shall be removed and evaluated at periodic intervals.

(3) Corrosion probes should be checked manually at intervals, or continuously or intermittently monitored or recorded, or both, to evaluate control of pipeline internal corrosion.

(4) A record of the internal condition of the pipe, of leaks and repairs from corrosion, and of liquids or solids quantities and corrosivity shall be kept and used as a basis for changes in the cleaning pig schedules, chemical treatment program, or liquid treatment facility.

(5) When pipe is uncovered, or on exposed piping where internal corrosion may be anticipated, pipe wall thickness measurement or monitoring should be made to evaluate internal corrosion.

(6) Where inspections, observation, or record analysis indicates internal corrosion is taking place to an extent that may be detrimental to public or employee safety, that portion of the system shall be repaired or reconditioned, and appropriate steps taken to mitigate the internal corrosion.

**463 EXTERNAL CORROSION CONTROL FOR PIPELINES EXPOSED TO ATMOSPHERE****463.1 General****(19)**

(a) Steel pipelines exposed to the atmosphere shall be protected from external corrosion by a suitable coating or jacket, unless it can be demonstrated by test or experience that the materials are resistant to corrosion in the



environment in which they are installed. Further information can be obtained from NACE RP 0281.

(b) The surface to be coated shall be free of deleterious materials, such as rust, scale, moisture, dirt, salt, oil, lacquer, and varnish. The surface preparation shall be compatible with the coating or jacket to be applied. Further information can be obtained from NACE/SSPC Joint Surface Preparation Standards.

(c) The coating or jacket selected shall possess characteristics that will provide adequate protection from the environment. Coatings and jackets shall completely cover the exposed structure and shall be applied in accordance with established specifications or manufacturer's recommendations.

(d) Special consideration shall be given to air-soil interfaces and splash zones.

## 464 PIPELINES IN ARCTIC ENVIRONMENTS

### 464.1 General

Pipeline facilities installed in arctic environments shall be coated and cathodically protected in the same manner as pipelines in temperate locations, and the same consideration shall be given to the need for protection from internal and atmospheric corrosion, except as specifically provided in this section.

### 464.2 External Coating Requirements

Selection of coatings for pipelines in low-temperature environments shall take into consideration the particular requirements of that environment. These include adhesion, resistance to cracking or damage during handling and installation in subfreezing temperatures, applicability of field joint coatings or coating repairs, compatibility with any applied cathodic protection, and resistance to soil stresses due to frost heave, seasonal temperature changes, or other requirements.

### 464.3 Cathodic Protection Facilities

**464.3.1 Criteria.** Criteria for cathodic protection shall be the same as for pipelines in temperate environments. Because higher driving voltages are normally required in frozen soils, the voltage impressed across the coating should be limited so that the coating is not subject to damage due to cathodic overvoltage or excessive current density.

#### 464.3.2 Impressed Current Facilities

(a) Impressed current facilities should be used on pipelines in permanently frozen soil. Such facilities are capable of providing the higher driving voltage needed to overcome the high resistivity of frozen soil. They should be installed at pump stations or other facilities where power is available and access for adjustment and maintenance is ensured. The effects of seasonal variations in

soil resistivity should be compensated for by using constant potential rectifiers or manual adjustments.

(b) Impressed current anode beds should be installed whenever feasible at a sufficient distance from the pipeline or other underground structures to achieve maximum current distribution (spread) along the pipeline and to reduce the peak potential at the pipeline.

(c) Where practical, anode beds shall be installed below the permafrost level or in other unfrozen locations, such as a stream or lake, to achieve better cathodic protection current distribution. Where anodes must be installed in permanently frozen ground, the volume of the anode backfill material should be increased to reduce the effective resistance between the anode and the surrounding earth.

(d) Impressed current facilities utilizing distributed or deep anode ground beds should be used to protect buried station facilities and steel pilings where used to support aboveground pipeline and associated facilities. The pilings and any other adjacent underground metallic facilities must be electrically interconnected to prevent detrimental interference.

**464.3.3 Galvanic Anode Installations.** Galvanic anodes (packaged or ribbon) may be needed on pipelines in permafrost areas to supplement impressed current facilities in localized thawed areas. This provides localized cathodic protection to those sections of pipe that might be shielded from adequate cathodic-protection current by the extreme high resistivity of the surrounding frozen soil.

### 464.4 Monitoring

Installation of calibrated current measurement spans should be considered in addition to the normal test points. These should be installed at sufficient intervals to evaluate current distribution along the protected pipeline and the effects of telluric currents prevalent in polar regions. These spans also provide contact points for measuring indications of possible coating damage due to stresses induced by a frozen environment.

### 464.5 Internal Corrosion Control

If it is anticipated that free water solutions will be present in the pipeline, possibly along with other potentially corrosive contaminants, suitable corrective measures shall be taken as prescribed in [section 462](#).

## 465 PIPELINES IN HIGH-TEMPERATURE SERVICE

### 465.1 General

Special consideration must be given to the corrosion control requirements of pipelines and other facilities in high-temperature service [above 150°F (66°C)]. Elevated temperatures tend to decrease the resistivity of buried or submerged pipeline environments and to increase the



electrochemical corrosion reaction as a result of accelerated ionic or molecular activity. Elevated temperatures typically occur downstream of pump stations or in gathering systems.

## 465.2 External Coating Requirements

Selection of coatings shall take into account the particular requirements for pipelines in high-temperature service. These include resistance to damage from soil stress and pipe movement, compatibility with any applied cathodic protection, and resistance to thermal degradation.

## 465.3 Cathodic Protection Facilities

**465.3.1 Criteria.** Criteria for cathodic protection shall be the same as for normal temperature service, except that recognition should be given to the effects of decreased resistivity and increased cathodic protection current requirements in elevated temperature service on any IR component of the pipe-to-soil potential measurement. Possible depolarization effects due to high-temperature operation shall also be considered.

**465.3.2 Galvanic Anodes.** Consideration shall be given to the impact on the performance of close galvanic anodes (especially bracelet or ribbon type) subject to elevated temperatures due to their proximity to a hot pipeline. Higher temperatures tend to increase both the current output and rate of degradation of most anode materials. Some anode materials may become more noble than steel at temperatures above 140°F (60°C) in certain electrolytes. Zinc anodes containing aluminum are also susceptible to intergranular corrosion above 120°F (49°C).

## 465.4 Internal Corrosion Control

When liquid known or anticipated to be corrosive is transported at elevated temperatures, special consideration shall be given to the identification and mitigation of possible internal corrosion. Such measures are necessary because corrosion reaction rates increase with elevated temperatures and are not stable. Appropriate mitigation and monitoring measures are given in [section 462](#).

# 466 EXTERNAL CORROSION CONTROL FOR THERMALLY INSULATED PIPELINES

## 466.1 New Installations

- (19) **466.1.1 General.** Special consideration must be given to the external corrosion control requirements of pipelines and other facilities that are thermally insulated due to operational requirements or for personnel safety.

Corrosion under insulation of facilities associated with liquid pipelines (piping, tanks, etc.) shall be addressed in accordance with NACE SP 0198.

The external surfaces of thermally insulated pipelines constructed as “pipe-in-pipe” shall be protected from corrosion as detailed elsewhere in this Chapter. The external metallic surfaces of thermally insulated pipelines constructed as “pipe-in-plastic” shall be protected from corrosion as detailed in [para. 466.1](#).

Due to the physical characteristics of thermal insulating systems, cathodic protection of the external metallic surfaces under the insulation system cannot be ensured. As such, ensuring the integrity of the thermal insulation system and the isolation of the metal surface from a corrosive environment is critical.

The external corrosion mitigation (or pipeline integrity) program for thermally insulated pipelines shall include either the monitoring of the integrity of the insulation system or an appropriate external metal loss monitoring program.

**466.1.2 External Coating Requirements.** External corrosion mitigation of thermally insulated pipelines shall be provided by an anticorrosion coating applied to the surface of the pipe, under the thermal insulation system. Selection of anticorrosion coatings shall take into account the particular requirements for pipelines in thermally insulated services. In addition to the general considerations for pipeline coatings listed in [para. 461.1.2](#), these coatings shall be resistant to damage from the stresses of movement due to operational thermal expansion/contraction cycles, compatible with the insulation system, and resistant to thermal degradation.

**466.1.3 Water Stops.** The thermal insulation system for buried or submerged pipelines should include provisions for prevention of migration of water through the insulation that may impact adjacent pipe joints. This may be achieved with water stops or alternative means.

**466.1.4 Cathodic Protection.** The external corrosion mitigation provided by anticorrosion coating for buried piping and pipelines may be supplemented by cathodic protection when appropriate as detailed in [paras. 466.1.4.1](#) and [466.1.4.2](#).

**466.1.4.1 External Anodes.** Cathodic protection may be provided using anodes that are located outside of the thermal insulation system jacket. Such anodes will provide cathodic protection to any external metallic pipeline surfaces that are exposed openly to the surrounding electrolyte.

**466.1.4.2 Internal Anodes.** Cathodic protection may be provided using anodes that are installed within the thermal insulation system jacket. Such anodes will provide cathodic protection to external metallic pipeline surfaces that are contained within the same electrolyte as are the anodes, in the event that the integrity of the insulation jacket has been compromised.

## 466.2 Existing Installations

The external corrosion mitigation (or pipeline integrity) program for existing thermally insulated pipelines shall include provisions to address the threat of corrosion under insulation. Factors to consider when developing a mitigation program for corrosion under insulation may include, but are not limited to, insulation jacket or weather barrier integrity, attention to areas of protrusions through the insulation jacket or weather barrier, use of in-line inspection tools, use of external NDE inspection tools, use of hydrostatic pressure testing, and use of direct assessment methodology.

## (19) 467 STRESS CORROSION AND OTHER PHENOMENA

Environmentally induced and other corrosion-related phenomena, including stress corrosion cracking, corrosion fatigue, hydrogen stress cracking, hydrogen embrittlement, corrosion under insulation, and microbiologically influenced corrosion, have been identified as causes of pipeline failure. Considerable knowledge and data have been acquired and assembled on these phenomena, and research is continuing as to their causes and prevention. Operating companies should be alert for evidence of such phenomena during all pipe inspections and at other such opportunities. Where evidence of such a condition is found, an investigative program shall be initiated and remedial measures taken as necessary. Any such evidence

shall be given consideration in all pipeline failure investigations. Operating companies should avail themselves of current technology on the subject or consult with knowledgeable experts, or both.

This paragraph must be limited to general statements rather than specific limits in regard to stress corrosion. Stress corrosion is currently the subject of investigative research programs and more specific data will certainly be available to the pipeline designer and operating company in the future. In the interim, this Code suggests that the user refer to the current state of the art. Cathodic protection current levels, quality of pipe surface preparation and coating, operating temperatures, stress levels, and soil conditions shall be considered in pipeline design and operations. Further information can be obtained from NACE SP 0204.

## 468 RECORDS

(a) Records indicating cathodically protected piping, cathodic protection facilities, and other structures affected by or affecting the cathodic protection system shall be maintained by the operating company.

(b) Records of tests, surveys, visual and instrumented inspection results, leaks, etc., necessary for evaluating the effectiveness of corrosion control measures shall be maintained and retained for as long as the piping remains in service.

# Chapter IX

## Offshore Liquid Pipeline Systems

### (19) A400 GENERAL STATEMENTS

(a) Chapter IX pertains only to offshore pipeline systems as defined in para. A400.1.

(b) This Chapter is organized to parallel the numbering and content of the first eight chapters of the Code. Paragraph designations are the same as those in the first eight chapters, with the prefix "A."

(c) All provisions of the first eight chapters of the Code are also requirements of this Chapter unless specifically modified herein. If the text in this Chapter adds requirements, the requirements in the original Chapter with the same title and number also apply. If a provision in this Chapter is in conflict with one or more provisions in other chapters, the provision in this Chapter shall apply.

(d) It is the intent of this Chapter to provide requirements for the safe and reliable design, installation, and operation of offshore liquid pipeline systems. It is not the intent of this Chapter to be all inclusive. Engineering judgment must be used to identify special considerations that are not specifically addressed. API RP 1111, API 2RD, and DNVGL-ST-F201 may be used as guides. It is not the intent of this Chapter to prevent the development and application of new equipment and technology. Such activity is encouraged as long as the safety and reliability requirements of the Code are satisfied.

#### A400.1 Scope

This Chapter covers the design, material requirements, fabrication, installation, inspection, testing, and safety aspects of the operation and maintenance of offshore pipeline systems. For purposes of this Chapter, offshore pipeline systems include offshore liquid pipelines, pipeline risers, offshore liquid-pumping stations, pipeline appurtenances, pipe supports, connectors, and other components as addressed specifically in the Code. See Figure 400.1.1-2.

#### A400.2 Definitions (Applicable to This Chapter Only)

Some of the more common terms relating to offshore liquid pipelines are defined below.

*buckle arrestor*: any device attached to, or made a part of, the pipe for the purpose of arresting a propagating buckle.

*buckle detector*: any means for detecting dents, excessive ovalization, or buckles in a pipeline.

*external hydrostatic pressure*: pressure acting on any external surface resulting from its submergence in water.

*flexible pipe*: pipe that is

(a) manufactured as a composite from both metal and nonmetal components

(b) capable of allowing large deflections without adversely affecting the pipe's integrity

(c) intended to be an integral part of the permanent liquid transportation system

Flexible pipe does not include solid metallic pipe, plastic pipe, fiber reinforced plastic pipe, rubber hose, or metallic pipes lined with nonmetallic linings or coatings.

*hyperbaric weld*: a weld performed at ambient hydrostatic pressure.

*offshore*: the area beyond the line of ordinary high water along that portion of the coast that is in direct contact with the open seas and beyond the line marking the seaward limit of inland coastal waters.

*offshore pipeline riser*: the vertical or near-vertical portion of an offshore pipeline between the platform piping and the pipeline at or below the seabed, including a length of pipe of at least five pipe diameters beyond the bottom elbow, bend, or fitting. Because of the wide variety of configurations, the exact location of transition among pipeline, pipeline riser, and platform piping must be selected on a case-by-case basis.

*offshore pipeline system*: includes all components of a pipeline installed offshore for the purpose of transporting liquid, other than production facility piping. Tanker or barge loading hoses are not considered part of the offshore pipeline system.

*offshore platform*: any fixed or permanently anchored structure or artificial island located offshore.

*pipe collapse*: flattening deformation of the pipe resulting in loss of cross-sectional strength and circular shape, which is caused by excessive external hydrostatic pressure acting alone.

*platform piping*: on offshore platforms producing hydrocarbons, platform piping is all liquid transmission piping and appurtenances between the production facility and the offshore pipeline riser(s). On offshore platforms

not producing hydrocarbons, platform piping is all liquid transmission piping and appurtenances between the risers. Because of a wide variety of configurations, the exact location of the transition between the offshore pipeline riser(s), platform piping, and production facility must be selected on a case-by-case basis.

*propagating buckle*: a buckle that progresses rapidly along a pipeline caused by the effect of external hydrostatic pressure on a previously formed buckle, local collapse, or other cross-sectional deformation.

*pull tube*: a conduit attached to an offshore platform through which a riser can be installed.

*pull-tube riser*: riser pipe or pipes installed through a pull tube (e.g., J-tube or I-tube).

*riser*: see *offshore pipeline riser*.

*seafloor bathymetry*: refers to water depths along the pipeline route.

*splash zone*: the area of the pipeline riser or other pipeline components that is intermittently wet and dry due to wave and tidal action.

*trawl board*: a structure that is attached to the bottom of commercial fishing nets and is dragged along the seafloor.

*vortex shedding*: the periodic shedding of fluid vortices and resulting unsteady flow patterns downstream of a pipeline span.

## (19) A401 LOADS

A number of physical parameters, henceforth referred to as loads, govern design of the offshore pipeline system so that it meets installation, operation, and other post-installation requirements. Some of the conditions that may influence the safety and reliability of an offshore pipeline system are

- (a) pressure
- (b) temperature
- (c) waves
- (d) current
- (e) seabed
- (f) wind
- (g) ice
- (h) seismic activity
- (i) platform motion
- (j) water depth
- (k) support settlement
- (l) accidental loads
- (m) marine vessel activity
- (n) fishing/recreational activities

The design of an offshore pipeline system is often controlled by installation considerations rather than by operating load conditions.

## A401.2 Application of Loads

### A401.2.2 Sustained Loads

**A401.2.2.1 General.** The design of an offshore pipeline system suitable for safe operation shall be based on considerations of the parameters listed below. These parameters shall be considered to the extent that they are significant to the proposed system.

All parts of the offshore pipeline system shall be designed for the most critical combinations of operational and environmental loads, acting concurrently, to which the system may be subjected. The most critical combination will depend on operating criteria during storm conditions. If full operations are to be maintained during storm conditions, then the system shall be designed for concurrent action of full operational and design environmental loads. If operations are to be reduced or discontinued during storm conditions, then the system shall be designed for both full sustained loads, plus maximum coincidental occasional loads, and design occasional loads, plus appropriate reduced sustained loads.

Sustained loads that shall be considered are those imposed on the pipeline system during its operation, excluding those resulting from occasional conditions.

Loads that should be considered sustained loads include

- (a) weight, including (as appropriate) the weight of
  - (1) pipe
  - (2) coatings and their absorbed water
  - (3) attachments to the pipe
  - (4) transported contents
- (b) buoyancy
- (c) internal and external pressure
- (d) thermal expansion and contraction
- (e) residual loads
- (f) overburden

Anticipated impact loads, such as those caused by trawl boards, should be considered as an operational load.

**A401.2.3 Occasional Loads.** Occasional loads that shall be considered are those imposed on the pipeline system by occasional conditions. Loads that should be considered under this category include, as appropriate, those arising due to

- (a) waves
- (b) current
- (c) wind
- (d) tides
- (e) ice loads (e.g., weight, floating impacts, scouring)
- (f) seismic events
- (g) dynamically induced soil loads (e.g., mudslides, soil liquefaction)

An appropriate design return interval storm shall be selected for the anticipated operational life of the offshore pipeline system but shall not be less than 100 yr.

Direction of waves, wind, and currents shall be considered to determine the most critical expected combination of the occasional loads to be used with the other classifications of loads, as described in [para. A401.2.4.1](#).

**A401.2.4 Construction Loads.** The design of an offshore pipeline system suitable for safe installation and the development of offshore pipeline construction procedures shall be based on consideration of the parameters listed in [paras. A401.2.4.1](#) and [A401.2.4.3](#). These parameters shall be considered to the extent that they are significant to the proposed system and applicable to the method of installation being considered.

All parts of the offshore pipeline system shall be designed for the most critical combinations of installation and environmental loads, acting concurrently, to which the system may be subjected.

**A401.2.4.1 Installation Loads.** Installation loads that shall be considered are those imposed on the pipeline system under anticipated installation conditions, excluding those resulting from environmental conditions.

Loads that should be considered as installation loads include

- (a) weight, including (as appropriate) the weight of
  - (1) pipe
  - (2) coatings and their absorbed water
  - (3) attachments to the pipe
  - (4) fresh water or sea water content (if pipe is flooded during installation)
- (b) buoyancy
- (c) external pressure
- (d) static loads imposed by construction equipment

When considering the effect of pipe and/or pipeline component weights (in air and submerged) on installation stresses and strains, the variability due to weight coating, manufacturing tolerances, and water absorption shall also be considered.

#### **A401.2.4.2 Hydrostatic Testing**

##### **A401.2.4.2.1 Loads for Hydrostatic Test Design.**

The design of an offshore pipeline system suitable for safe hydrostatic testing and the development of offshore pipeline hydrostatic test procedures shall be based on consideration of the parameters listed in [paras. A401.2.4.2.2](#), [A401.2.4.2.3](#), and [A401.2.4.2.4](#). These parameters shall be considered to the extent that they are significant to the proposed test.

All parts of the offshore pipeline system shall be designed for the most critical combinations of hydrostatic test and occasional loads, acting concurrently, to which the system may be subjected.

**A401.2.4.2.2 Hydrostatic Test Loads.** Hydrostatic test loads that shall be considered are those imposed on the offshore pipeline system under anticipated test conditions, excluding those resulting from occasional conditions.

Loads that should be considered hydrostatic test loads include

- (a) weight, including (as appropriate) the weight of
  - (1) pipe
  - (2) coatings and their absorbed water
  - (3) attachments to the pipe
  - (4) fresh water or sea water used for hydrostatic test
- (b) buoyancy
- (c) internal and external pressure
- (d) thermal expansion and contraction
- (e) residual loads
- (f) overburden

**A401.2.4.2.3 Environmental Loads During Hydrostatic Test.** Environmental loads that shall be considered are those imposed on the pipeline system by environmental conditions. Loads that should be considered under this category include, as appropriate, those arising due to

- (a) waves
- (b) current
- (c) wind
- (d) tides

An appropriate design return interval storm shall be selected for the anticipated hydrostatic test duration but shall not be less than 1 yr.

Direction of waves, wind, and currents shall be considered to determine the most critical expected combination of the environmental loads to be used with the hydrostatic test loads, as described in [para. A401.2.4.2.1](#).

**A401.2.4.2.4 Bottom Soils.** When establishing on-bottom stability requirements and maximum allowable spans for irregular seabeds, consideration shall be given to seabed soil characteristics.

**A401.2.4.3 Environmental Loads During Installation.** Environmental loads that should be considered under this category include, as appropriate, those arising due to

- (a) waves
- (b) current
- (c) wind
- (d) tides
- (e) ice
- (f) dynamic loads imposed by construction equipment and vessel motions

The effects of large tidal changes and water depth variations on construction equipment shall be considered.

An appropriate design return interval storm shall be selected for the anticipated installation duration. This design return interval shall not be less than 3 times the expected exposure period for the pipeline during installation, or 1 yr, whichever is longer.

Direction of waves, wind, and currents shall be considered to determine the most critical expected combination of the environmental loads to be used with the installation loads, as described in [para. A401.2.4.1](#).



Loads imposed by construction equipment and vessel motions vary with the construction method and construction vessel selected. The limitations and behavioral characteristics of installation equipment shall be considered in the installation design. The effect of vessel motions on the pipe and its coating shall be considered.

Local environmental forces are subject to radical change in offshore areas. As a result, those potential changes should be considered during installation contingency planning as well as during installation design.

**A401.2.4.4 Bottom Soils.** Soil characteristics shall be considered in on-bottom stability analysis during the installation period, span analysis, and when installation procedures are developed for the following:

- (a) riser installation in pull tubes
- (b) laying horizontal curves in the pipeline routing
- (c) pipeline bottom tows
- (d) trenching and backfilling

**A401.2.5 Bottom Soils.** When establishing on-bottom stability requirements and maximum allowable spans for irregular seabeds, consideration shall be given to seabed soil characteristics.

#### A401.4 Route Selection Considerations

(a) Offshore pipeline routes shall be selected to minimize the adverse effects of construction loads (see para. A401.2.4). These loads include the following:

- (1) sustained loads (see para. A401.2.2)
- (2) occasional loads (see para. A401.2.3)
- (3) construction loads (see para. A401.2.4)

(b) Selection of offshore pipeline routes shall consider the capabilities and limitations of anticipated construction equipment.

(c) Surveys of the pipeline route shall be conducted to identify

- (1) seabed materials
- (2) subsea (including sub-bottom) and surface features that may represent potential hazards to the pipeline construction and operations
- (3) subsea (including sub-bottom) and surface features that may be adversely affected by pipeline construction and operations, including archaeological and sensitive marine areas

- (4) turning basins
- (5) anchorage areas
- (6) shipping lanes
- (7) foreign pipeline and other utility crossings

(d) Routing shall be selected to avoid, to the extent practical, the identified hazards.

## A402 CALCULATION OF STRESSES

(19)

### A402.3 Stresses From Internal Pressure

The calculations of stresses in section 402 are superseded by the provisions of paras. A402.3.1 and A402.3.2.

Design and installation analyses shall be based on accepted engineering methods, material strengths, and applicable design conditions.

#### A402.3.1 Strength Criteria During Installation and Testing

(a) *Allowable Stress Values.* The maximum longitudinal stress due to axial and bending loads during installation shall be limited to a value that prevents pipe buckling and that will not impair the serviceability of the installed pipeline system. Other stresses resulting from pipeline installation activities, such as spans, shall be limited to the same criteria. Instead of a stress criterion, an allowable installation strain limit may be used.

(b) *Design Against Buckling.* The offshore pipeline system shall be designed and installed in a manner to prevent local buckling of the pipe wall, collapse, and column buckling during installation. Design and installation procedures shall consider the effect of external hydrostatic pressure; bending, axial, and torsional loads; impact; mill tolerances in the wall thickness; out-of-roundness; and other applicable factors. Consideration shall also be given to mitigation of propagation buckling that may follow local buckling or denting. The pipe wall thickness shall be selected to resist collapse due to external hydrostatic pressure.

(c) *Design Against Fatigue.* The pipeline shall be designed and installed to limit anticipated stress fluctuations to magnitudes and frequencies that will not impair the serviceability of the installed pipeline. Loads that may cause fatigue include wave action and vibrations induced by vortex shedding. Pipelines and riser spans shall be designed to prevent vortex-induced resonant vibrations, when practical. When vibrations must be tolerated, the resulting stresses due to vibration shall be considered. If alternative acceptance standards for girth welds in API 1104 are used, the cyclic stress analysis shall include the determination of a predicted fatigue spectrum to which the pipeline is exposed over its design life.

(d) *Design Against Fracture.* Prevention of fractures during installation shall be considered in material selection in accordance with the requirements of para. A423.2. Welding procedures and weld defect acceptance criteria shall consider the need to prevent fractures during installation. See paras. 434.8.5 and A434.8.5.

(e) *Design Against Loss of In-Place Stability.* Design against loss of in-place stability shall be in accordance with the provisions of para. A402.3.2(e), except that the installation design wave and current conditions shall be based on the provisions of para. A401.2.4.3. If



the pipeline is to be trenched, it shall be designed for stability during the period prior to trenching.

(f) *Impact.* During the period when the pipe is susceptible to impact damage during installation and testing, consideration shall be given to impacts due to

- (1) anchors
- (2) trawl boards
- (3) vessels
- (4) ice keels
- (5) other foreign objects

(g) *Residual Stresses.* The pipeline system shall normally be installed in a manner so as to minimize residual stresses. The exception shall be when the designer purposefully plans for residual stresses (e.g., reeled pipe, cold springing of risers, pull-tube risers).

(h) *Flexible Pipe.* The manufacturer's recommended installation procedures should be adhered to during installation. Flexible pipe shall be designed or selected to prevent failure due to the combined effects of external pressure, internal pressure, torsional forces, axial forces, and bending. (See API RP 17B.)

### A402.3.2 Strength Criteria During Operations

(a) *Allowable Stress Values.* Allowable stress values for steel pipe during operation shall not exceed those calculated by the equations in (1) through (3) below.

(1) *Hoop Stress.* For offshore pipeline systems, the tensile hoop stress due to the difference between internal and external pressures shall not exceed the values given below, in eq. (1).

$S_h$  shall be calculated by eq. (2) or eq. (3). It is recommended that eq. (2) be used for  $D/t$  greater than or equal to 30 and that eq. (3) be used for  $D/t$  less than 30.

NOTE: Sign convention is such that tension is positive and compression is negative.

$$S_h \leq F_1(S_y) \quad (1)$$

(U.S. Customary Units)

$$S_h = (P_i - P_e) \frac{D}{2t} \quad (2)$$

(SI Units)

$$S_h = (P_i - P_e) \frac{D}{20t}$$

(U.S. Customary Units)

$$S_h = (P_i - P_e) \frac{D - t}{2t} \quad (3)$$

(SI Units)

$$S_h = (P_i - P_e) \frac{D - t}{20t}$$

where

$D$  = nominal outside diameter of pipe, in. (mm)

$F_1$  = hoop stress design factor from Table A402.3.2-1

$P_e$  = external pressure, psig (bar)

$P_i$  = internal design pressure, psig (bar)

$S_h$  = hoop stress, psi (MPa)

$S_y$  = specified minimum yield strength, psi (MPa)

$t$  = nominal wall thickness, in. (mm)

(2) *Longitudinal Stress.* For offshore pipeline systems, the longitudinal stress shall not exceed values found from

$$|S_L| \leq F_2(S_y)$$

where

$A$  = cross-sectional area of pipe material, in.<sup>2</sup> (mm<sup>2</sup>)

$F_2$  = longitudinal stress design factor from Table A402.3.2-1

$F_a$  = axial force, lb (N)

$i_i$  = in-plane stress intensification factor from Table 402.1-1

$i_o$  = out-of-plane stress intensification factor from Table 402.1-1

$M_i$  = in-plane bending moment, in.-lb (N·m)

$M_o$  = out-of-plane bending moment, in.-lb (N·m)

$S_a$  = axial stress, psi (positive tensile or negative compressive) (MPa)

$$= F_a/A$$

$S_b$  = maximum resultant bending stress, psi (MPa)

$$= \pm \sqrt{(i_i M_i)^2 + (i_o M_o)^2} / Z$$

$S_L$  = maximum longitudinal stress, psi (positive tensile or negative compressive) (MPa)

$$= S_a + S_b \text{ or } S_a - S_b, \text{ whichever results in the larger stress value}$$

$S_y$  = specified minimum yield strength, psi (MPa)

$Z$  = section modulus of the pipe, in.<sup>3</sup> (cm<sup>3</sup>)

$||$  = absolute value

(3) *Combined Stress.* For offshore pipeline systems, the combined stress shall not exceed the value given by the maximum shear stress equation (Tresca combined stress)

$$2 \left[ \sqrt{\left( \frac{S_L - S_h}{2} \right)^2 + S_t^2} \right] \leq F_3(S_y)$$

where

$A$  = pipe cross-sectional area, in.<sup>2</sup> (mm<sup>2</sup>)

$F_3$  = combined stress design factor from Table A402.3.2-1

$F_a$  = axial force, lb (N)

$i_i$  = in-plane stress intensification factor from Table 402.1-1

$i_o$  = out-of-plane stress intensification factor from Table 402.1-1

$M_i$  = in-plane bending moment, in.-lb (N·m)

$M_o$  = out-of-plane bending moment, in.-lb (N·m)

$M_t$  = torsional moment, in.-lb (N·m)

**Table A402.3.2-1 Design Factors for Offshore Pipeline Systems**

Location	Hoop Stress, $F_1$	Longitudinal Stress, $F_2$	Combined Stress, $F_3$
Pipeline	0.72	0.80	0.90
Riser and platform piping [Note (1)]	0.60	0.80	0.90

GENERAL NOTE: In the setting of design factors, due consideration has been given to, and allowance has been made for, the underthickness tolerance and maximum allowable depth of imperfections provided for in the specifications approved by the Code.

NOTE: (1) Platform piping does not include production facility piping on a platform; see definitions in para. A400.2.

$S_a$  = axial stress, psi (positive tensile or negative compressive) (MPa)

$$= F_a / A$$

$S_b$  = maximum resultant bending stress, psi (MPa)

$$= \pm \sqrt{(i_i M_i)^2 + (i_o M_o)^2} / Z$$

$S_h$  = hoop stress, psi (MPa)

$S_L$  = maximum longitudinal stress, psi (positive tensile or negative compressive) (MPa)

=  $S_a + S_b$  or  $S_a - S_b$ , whichever results in the larger stress value

$S_t$  = torsional stress, psi (MPa)

$$= M_t / 2Z$$

$S_y$  = specified minimum yield strength, psi (MPa)

$Z$  = section modulus of the pipe, in.<sup>3</sup> (cm<sup>3</sup>)

Alternatively, the maximum distortional energy theory (Von Mises combined stress) may be used for limiting combined stress values. Accordingly, the combined stress should not exceed values given by

$$\sqrt{S_h^2 - S_L S_h + S_L^2 + 3S_t^2} \leq F_3(S_y)$$

(4) *Strain*. When the pipeline experiences a predictable noncyclic displacement of its support (e.g., fault movement along the pipeline route or differential subsidence along the line) or pipe sag before support contact, the longitudinal and combined stress limits may be replaced with an allowable strain limit, so long as the consequences of yielding do not impair the serviceability of the installed pipeline. The permissible maximum longitudinal strain depends on the ductility of the material, any previously experienced plastic strain, and the buckling behavior of the pipe. Where plastic strains are anticipated, the pipe eccentricity, pipe out-of-roundness, and the ability of the weld to undergo such strains without detrimental effect should be considered. These same criteria may be applied to pull tube or bending shoe risers or pipe installed by the reel method.

(b) *Design Against Buckling*. The pipeline shall be designed with an adequate margin of safety to prevent local buckling of the pipe wall, collapse, and column buckling during operations. Design and operating procedures shall consider the effect of external hydrostatic pressure; bending, axial, and torsional loads; impact; mill tolerances in the wall thickness; out-of-roundness; and other appli-

cable factors. Consideration shall also be given to mitigation of propagation buckling that may follow local buckling or denting. The pipe wall thickness shall be selected to resist collapse due to external hydrostatic pressure.

(c) *Design Against Fatigue*. The pipeline shall be designed and operated to limit anticipated stress fluctuations to magnitudes and frequencies that will not impair the serviceability of the pipeline. Loads that may cause fatigue include internal pressure variations, wave action, and pipe vibration, such as that induced by vortex shedding. Pipe and riser spans shall be designed so that vortex-induced resonant vibrations are prevented, whenever practical. When vibrations must be tolerated, the resulting stresses due to vibration shall be considered in the combined stress calculations in (a). In addition, calculated fatigue failure shall not result during the design life of the pipeline and risers.

(d) *Design Against Fracture*. Prevention of fractures during operation shall be considered in material selection in accordance with the requirements of para. A423.2. Welding procedures and weld defect acceptance criteria shall consider the need to prevent fractures during operation. See paras. 434.8.5 and A434.8.5.

(e) *Design Against Loss of In-Place Stability*

(1) *General*. Pipeline design for lateral and vertical on-bottom stability is governed by permanent features such as seafloor bathymetry and soil characteristics and by transient events, such as hydrodynamic, seismic, and soil behavior events, having a significant probability of occurrence during the life of the system. Design conditions to be considered are provided in (2) through (4) below.

The pipeline system shall be designed to prevent horizontal and vertical movements or shall be designed so that any movements will be limited to values not causing allowable stresses and strains to be exceeded. Typical factors to be considered in the stability design include

- (-a) wave and current forces
- (-b) soil properties
- (-c) scour and resultant spanning
- (-d) soil liquefaction
- (-e) slope failure

Stability may be obtained by such means as, but not limited to, adjusting pipe submerged weight, trenching and/or covering of pipe, or anchoring.

When calculating hydrodynamic forces, the fact that wave forces vary spatially along the length of the pipeline may be taken into account.

Two on-bottom stability design conditions that shall be considered are installation and operational.

(2) *Design Wave and Current Conditions.* Operational design wave and current conditions shall be based on an event having a minimum return interval of not less than 100 yr. The most unfavorable expected combination of wave and current conditions shall be used. Maximum wave and maximum current conditions do not necessarily occur simultaneously. When selecting the most unfavorable condition, consideration must be given to the timing of occurrence of the wave and current direction and magnitude.

(3) *Stability Against Waves and Currents.* The submerged weight of the pipe shall be designed to resist or limit movement to amounts that do not cause the longitudinal and combined stresses, as calculated by the equations in (a), to exceed the limits specified in (a). The submerged weight may be adjusted by weight coating and/or increasing pipe wall thickness. Hydrodynamic forces shall be based on the wave and current values for the design condition at the location [see (2)].

Wave and current direction and concurrence shall be considered.

The pipeline and its appurtenances may be lowered below bottom grade to provide stability.

Backfill or other protective covering options shall use materials and procedures that preclude damage to the pipeline and coatings.

Anchoring may be used alone or in conjunction with other options to maintain stability. The anchors shall be designed to withstand lateral and vertical loads expected from the design wave and current condition. Anchors shall be spaced to prevent excessive stresses in the pipe. Scour shall be considered in the design of the anchoring system. The effect of anchors on the cathodic protection system shall be considered.

Intermittent block-type, clamp-on, or set-on weights (river weights) shall not be used on offshore pipelines where there is a potential for the weight to become unsupported because of scour.

(4) *Shore Approaches.* Pipe in the shore approach zone shall be installed on a suitable above-water structure or lowered or bored to the depth necessary to prevent scouring, spanning, or stability problems that affect integrity and safe operation of the pipeline during its anticipated service life. Seasonal variation in the near-shore thickness of seafloor sediments and shoreline erosion over the pipeline service life shall be considered.

(5) *Slope Failure and Soil Liquefaction.* The pipelines shall be designed for slope failure in zones where they are expected (mudslide zones, steep slopes, areas of seismic slumping). If it is not practical to design the pipeline system to survive the event, the pipeline shall be designed for controlled breakaway with provisions to minimize loss of the pipeline contents.

Design for the effects of liquefaction shall be performed for areas of known or expected occurrence. Soil liquefaction normally results from cyclic wave overpressures or seismic loading of susceptible soils. The bulk specific gravity of the pipeline shall be selected, or alternative methods shall be selected to ensure both horizontal and vertical stability.

Seismic design conditions used to predict the occurrence of bottom liquefaction or slope failure shall be at least as severe as those used for the operating design strength calculations for the pipeline. Occurrence of soil liquefaction due to wave overpressures shall be based on a storm interval of not less than 100 yr.

(6) *Bottom Soils.* The pipe-soil interaction factors that are used shall be representative of the bottom conditions at the site.

(f) *Impact.* During operations, consideration shall be given to impacts due to

- (1) anchors
- (2) trawl boards
- (3) vessels
- (4) ice keels
- (5) other foreign objects

**A402.3.3 Design of Clamps and Supports.** Clamps and supports shall be designed such that a smooth transfer of loads is made from the pipeline or riser to the supporting structure without highly localized stresses due to stress concentrations. When clamps are to be welded to the pipe, they shall fully encircle the pipe and be welded to the pipe by a full-encirclement weld. The support shall be attached to the encircling member and not the pipe.

All welds to the pipe shall be nondestructively tested. Clamps and supports shall be designed in accordance with the requirements of API RP 2A-WSD.

Clamps and support design shall consider the corrosive effects of moisture-retaining gaps and crevices and galvanically dissimilar metals.

**A402.3.4 Design of Connectors and Flanges.** Connectors and flanges shall be designed or selected to provide the smooth transfer of loads and prevent excessive deformation of the attached pipe.

**A402.3.5 Design of Structural Pipeline Riser Protectors.** Where pipeline risers are installed in locations subject to impact from marine traffic, protective devices shall be installed in the zone subject to damage to protect the pipe and coating.

**A402.3.6 Design and Protection of Special Assemblies.** Design of special assemblies, such as connections, subsea tie-in assemblies, subsea valves, expansion loops, seabed riser connections, and subsea pipeline manifolds, shall consider the additional forces and effects imposed by a subsea environment. Such additional considerations include design storm currents and potential for seabed movement in soft sediments, soil liquefaction, increased potential for corrosion, thermal expansion and contraction, and stress due to installation procedures.

Appropriate measures shall be taken to protect special assemblies in areas where the assemblies are subject to damage by outside forces, such as fishing and marine construction activities.

**A402.3.7 Design of Flexible Pipe.** Due to its composite makeup, the mechanical behavior of flexible pipe is significantly different from that of steel pipe. Flexible pipe may be used for offshore pipelines if calculations and/or test results verify that the pipe can safely withstand loads considered in [paras. A401.2.2, A401.2.4, and A401.2.4.2](#). Careful consideration should be given to the use of flexible pipe due to its permeable nature and possible rapid decompression failure of the liner material and collapse of the inner liner due to residual gas pressure in the annulus upon pipeline depressurization. (See API RP 17B.)

**A402.3.8 Design of Pipeline Crossings.** Subsea pipeline crossings shall be designed to provide a minimum 12 in. (300 mm) separation between the two lines. Dielectric separation of the two pipelines shall be considered in design of pipeline crossings. Soil settlement, scour, and cyclical loads shall be considered in the design of pipeline crossings in order to ensure that the separation is maintained for the design life of both lines.

When two liquid pipelines cross, the longitudinal stress and combined stress, as calculated by the equations in [para. A402.3.2\(a\)](#), shall not exceed the limits specified in [Table A402.3.2-1](#). Where appropriate, allowable strain criteria in [para. A402.3.2\(a\)\(4\)](#) may be used in lieu of allowable stress criteria. Where crossing pipelines are governed by different codes, the allowable stress limits shall be in accordance with the provisions of the applicable code.

## (19) A403 CRITERIA FOR PIPELINES

### A403.2 Criteria for Pipe Wall Thickness and Allowances

**A403.2.1 Criteria.** For offshore pipeline systems, the applicable allowable stress value specified and defined in [para. 403.2.1](#) shall be as follows:

$$S = F_1(S_y)$$

where

$F_1$  = hoop stress design factor from [Table A402.3.2-1](#)  
 $S_y$  = specified minimum yield strength, psi (MPa)

**A403.2.6 Weld Joint Factors.** Pipe with a weld joint factor less than 1 ([Table 403.2.1-1](#)) shall not be used in offshore pipeline systems.

### A403.9 Design for Expansion and Flexibility

Unburied subsea pipeline systems and platform piping shall be considered as aboveground piping (see [paras. 403.9.1 and 403.9.3](#)) where such definition is applicable.

Thermal expansion and contraction calculations shall consider the effects of fully saturated backfill material on soil restraint.

Allowable strength criteria shall be in accordance with [para. A402.3.2](#) in lieu of the calculation of stresses listed in [section 402](#). Equations in [paras. 402.5.1 and 402.5.2](#) are valid for calculating the indicated stresses. See [paras. A401.2.2 and A401.2.4.2](#) for loads that must be considered in design. Where appropriate, allowable strain criteria in [para. A402.3.2\(a\)\(4\)](#) may be used in lieu of allowable stress criteria.

When an offshore pipeline is to be laid across a known fault zone or in an earthquake-prone area, consideration shall be given to the need for flexibility in the pipeline system and its components to minimize the possibility of damage due to seismic activity. Flexibility in the pipeline system may be provided by installation of the pipeline on or above the seabed and/or by use of breakaway couplings, slack loops, flexible pipe sections, or other site-specific solutions.

## A404 CRITERIA FOR FITTINGS, ASSEMBLIES, AND OTHER COMPONENTS (ALTERNATIVELY, CRITERIA FOR COMPONENTS)

### A404.2 Directional Changes

**A404.2.4 Mitered Bends.** Mitered bends are prohibited in offshore liquid pipeline systems.

### A404.3 Branch Connections

#### A404.3.5 Reinforcement of Single Openings

(a) When welded branch connections are made to pipe in the form of a single connection, or in a header or manifold as a series of connections, the design shall be adequate to control stress levels in the pipe within safe limits. The construction shall take cognizance of the stresses in the remaining pipe wall due to the opening in the pipe or header, the shear stresses produced by the pressure acting on the area of the branch opening, and any external loading due to thermal movement, weight, vibration, etc., and shall meet the minimum requirements listed in [Table 404.3.4-1](#). The following paragraphs provide



design rules based on the stress intensification created by the existence of a hole in an otherwise symmetrical section. External loadings, such as those due to thermal expansion or unsupported weight of connecting pipe, have not been evaluated. These factors should be given attention in unusual designs or under conditions of cyclic loading.

Pipe that has been cold worked solely for the purpose of increasing the yield strength to meet the specified minimum yield strength is prohibited in offshore liquid pipeline systems. This does not preclude the use of pipe that has been cold worked specifically for the purpose of meeting dimensional requirements.

#### **A404.3.6 Reinforcement of Multiple Openings**

(d) Pipe that has been cold worked solely for the purpose of increasing the yield strength to meet the specified minimum yield strength is prohibited in offshore liquid pipeline systems. This does not preclude the use of pipe that has been cold worked specifically for the purpose of meeting dimensional requirements.

#### **A404.4 Flanges**

- (19) **A404.4.3 Cast Iron Flanges Within Scope of Standard Sizes.** Paragraph 404.4.3 does not apply. Cast iron or ductile iron flanges are prohibited for applications in offshore liquid pipeline systems.

**A404.4.6 Flange Facings.** Ring joint-type flanges are preferred in offshore liquid pipeline systems.

#### **A404.5 Valves**

**A404.5.1 General.** Paragraph 404.5.1 as it relates to cast iron valves does not apply. Cast iron or ductile iron valves are prohibited for applications in offshore liquid pipeline systems.

#### **A404.6 Reducers**

**A404.6.3 Orange Peel Swages.** Orange peel swages are prohibited in offshore liquid pipeline systems, other than temporary construction components or other non-pressure-containing components.

#### **A404.7 Closures**

**A404.7.4 Fabricated Closures.** Orange peel bull plugs and fishtails are prohibited in offshore liquid pipeline systems, other than temporary construction components or other non-pressure-containing components.

#### **A404.8 Joints**

- (19) **A404.8.3 Threaded Joints.** Threaded connections for in-line piping component sizes NPS 2 (DN 50) or larger are prohibited in offshore pipeline systems, except as permitted in para. A406.2.

### **A405 PIPE**

(19)

#### **A405.1 Steel Pipe**

(a) New pipe of the specifications listed in Table 423.1-1 may be used in accordance with the design equations of para. 403.2.1 subject to para. A403.2.1 and to the testing requirements of paras. 437.1.4(a)(1), 437.1.4(a)(2), 437.1.4(a)(4), 437.1.4(a)(5), 437.1.4(b), 437.1.4(c), 437.4.1, and A437.1.4.

(b) Pipe that has been cold worked solely for the purpose of increasing the yield strength to meet the specified minimum yield strength is prohibited in offshore liquid pipeline systems. This does not preclude the use of pipe that has been cold worked specifically for the purpose of meeting dimensional requirements.

#### **A405.2 Flexible Pipe**

Selection of flexible pipe shall be in accordance with API RP 17B. (See also para. A403.2.1.)

### **A406 OTHER DESIGN CONSIDERATIONS**

#### **A406.1 Pigs and Internal Inspection Tools**

When specifying in-line piping components for offshore pipelines, consideration shall be given to the need for running pipeline pigs and internal inspection tools. Selection of bend radius, launcher and receiver traps, bend configuration, internal diameter variations (including ovality), and other internal obstructions shall allow the passage of such devices, except where not practical.

#### **A406.2 Special Components**

System components that are not specifically covered in this Code shall be validated for fitness by either of the following:

(a) documented full-scale prototype testing of the components or special assemblies

(b) a documented history of successful usage of these components or special assemblies produced by the same design method

Documentation shall include design and installation methods that have been proven for the service for which the component is intended.

Care should be exercised in any new application of existing designs to ensure suitability for the intended service.

#### **A406.3 Design of Pipe-Supporting Elements**

(19)

See para. A402.3.3 for additional provisions.

## A423 MATERIALS — GENERAL REQUIREMENTS

### A423.1 Acceptable Materials and Specifications

Concrete weight coating materials (cement, aggregate, reinforcing steel) shall meet or exceed the requirements of applicable ASTM standards.

Flexible pipe shall be manufactured from materials meeting the requirements of API RP 17B and ASTM or ASME standards applicable to the materials selected by the designer.

### (19) A423.2 Limitations on Materials

“Unidentified” pipe, plastic pipe, ASTM A120 pipe, plastic pipe with nonmetallic reinforcement, cast iron pipe, ductile iron pipe, and pipe that has been cold worked in order to meet the specified minimum yield strength are prohibited in offshore liquid pipeline systems. This does not preclude the use of pipe that has been cold worked specifically for the purpose of meeting dimensional requirements.

In addition to the requirements contained in referenced standards, certain other requirements may be considered for components used offshore, depending on water depth, water temperature, internal pressure, product composition, product temperature, installation method, and/or other loading conditions. For example, consideration of additional limitations or requirements for pipe may include one or more of the following:

- (a) wall thickness tolerance
- (b) outside diameter tolerance
- (c) out-of-roundness tolerance
- (d) maximum and minimum yield and tensile strengths
- (e) pipe chemistry limitations
- (f) fracture toughness
- (g) hardness
- (h) pipe mill hydrostatic testing and other nondestructive testing

For sour service (H<sub>2</sub>S), refer to NACE MR 0175/ISO 15156.

## A434 CONSTRUCTION

### A434.2 Qualifications

- (19) **A434.2.2 Inspection.** Repairs required during new construction shall also be in accordance with paras. A434.8 and A461.1.2.

### A434.3 Right-of-Way

**A434.3.3 Survey and Staking or Marking.** The route of the offshore pipeline shall be surveyed, and the pipeline shall be properly located within the right-of-way by maintaining survey route markers or by surveying during installation.

### A434.6 Ditching

The provisions of para. 434.6 are not applicable for offshore pipelines. Offshore pipelines should be trenched where necessary for stability, mechanical protection, or prevention of interference with maritime activities.

The methods and details of the pipeline trenching and lowering operations shall be based on site-specific conditions. Methods and details shall be selected to prevent damage to the pipe, coating, and pipeline appurtenances.

### A434.7 Bends, Miters, and Elbows

Miter bends shall not be used in offshore liquid pipeline systems.

#### A434.7.1 Bends Made From Pipe

(a) Pipe that has been cold worked solely for the purpose of increasing the yield strength to meet the specified minimum yield strength is prohibited in offshore liquid pipeline systems. This does not preclude the use of pipe that has been cold worked specifically for the purpose of meeting dimensional requirements.

### A434.8 Welding

(19)

**A434.8.3 Welder and Welding Procedure Qualification.** Welding procedures and welders performing hyperbaric welding on offshore pipeline systems shall be qualified in accordance with the testing provisions of either API 1104 or ASME BPVC, Section IX, as supplemented by AWS D3.6M for type “O” welds.

#### A434.8.5 Required Inspection and Acceptance Criteria

##### (a) Required Inspection

(2) Welds in offshore pipeline systems may also be evaluated on the basis of (b) below.

(3) The requirements of para. 434.8.5(a)(3) are superseded by the following provisions. All circumferential welds on offshore pipeline systems shall meet the requirements in para. 434.8.5(a) for a pipeline that would operate at a hoop stress of more than 20% of the specified minimum yield strength of the pipe. One hundred percent of the total number of circumferential butt welds on offshore pipeline systems shall be nondestructively inspected, if practical; but in no case shall less than 90% of such welds be inspected. The inspection shall cover 100% of the length of such inspected weld.

(b) *Inspection Methods and Acceptable Standards.* For girth welds in offshore pipeline systems, alternative flaw acceptance limits may be based on fracture mechanics analysis and fitness-for-purpose criteria as described by API 1104. Such alternative acceptance standards shall be supported by appropriate stress analyses, supplementary welding procedure test requirements, and non-destructive examinations beyond the minimum requirements specified herein. The accuracy of the



nondestructive techniques for flaw depth measurement shall be verified.

#### **A434.8.9 Stress Relieving**

(a) On offshore pipeline systems, the demonstration specified in [para. 434.8.9\(a\)](#) shall be conducted on materials and under conditions that simulate, as closely as practical, the actual production welding.

#### **A434.11 Backfilling**

Backfilling of trenched offshore pipelines is not normally required but may sometimes be utilized to provide additional stability or protection.

#### **A434.13 Special Crossings**

- (19) **A434.13.1 Water Crossings.** See [para. A402.3.2\(e\)\(3\)](#) concerning the use of river weights.

#### **A434.15 Block and Isolating Valves**

##### **A434.15.1 General**

(a) Block and isolating valves shall be selected to provide timely closure and to limit both property and environmental damage and provide safety under emergency conditions.

(b) On offshore platforms, consideration shall be given to locating block and isolating valves, or valve operator controls where used, in areas that are readily accessible under emergency conditions.

(c) Submerged valves shall be marked or spotted by survey techniques and recorded on permanently retained as-built records to facilitate location when operation is required.

#### **A434.18 Line Markers**

Line markers are not required on offshore pipeline systems.

- (19) **A434.25 Offshore Pipeline Construction**

**A434.25.1 Pipe Depth and Alignment.** Plans and specifications shall describe alignment of the pipeline, its design depth below mean water level, and the depth below the sea bottom, if trenching is prescribed. Special consideration shall be given to depth of cover and other means of protecting the pipeline in the surf zone and other areas of potential hazards, such as near platforms, anchorage areas, and shipping fairways.

**A434.25.2 Installation Procedures and Equipment Selection.** Installation procedures shall be prepared prior to beginning construction. Installation procedures shall address the design considerations in [para. A401.2.4](#) and strength considerations in [para. A402.3.1](#).

**A434.25.3 Movement of Existing Pipelines.** Consideration should be given to reducing operating pressures in the existing pipelines to obtain the lowest practical stress levels prior to movement of the existing lines. Whether the pipeline pressure is reduced or not, the following steps should be taken prior to movement of the existing lines:

(a) perform a physical survey to determine the actual position of the pipeline

(b) determine wall thickness and mechanical properties of the existing pipeline section to be moved

(c) investigate possible pipe stress that may exist in the pipeline in its present condition

(d) calculate additional stresses imposed by the proposed movement operation

(e) prepare a detailed procedure for the proposed movement

Investigation of the possible pipe stresses that may be induced in the existing pipeline during the relocation should be performed regardless of the anticipated internal pressure. This investigation should consider appropriate elevation tolerances for the lowering. Pipe stresses resulting from the relocation should not exceed the criteria in [para. A402.3.1](#), and pipe stresses resulting from existing pipeline operation after lowering should not exceed the criteria in [para. A402.3.2](#).

### **A436 INSPECTION**

#### **A436.2 Qualification of Inspectors**

In addition to the requirements of [para. 436.2](#), offshore inspection personnel shall be capable of inspecting the following, as applicable:

(a) offshore vessel positioning systems

(b) diving operations

(c) remotely operated vehicle (ROV) operations

(d) pipeline trenching and burial operations

(e) special services for testing and inspection of offshore pipeline facilities, such as subsea pipeline lateral tie-ins, and subsea pipeline crossings as may be required

(f) pipelay parameters

#### **A436.5 Type and Extent of Examination Required**

##### **A436.5.1 Visual**

(19)

(b) *Construction*

(19) When offshore pipelines are trenched, the condition of the trench, trench depth, and fit of the pipe to the trench shall be inspected when feasible.

(20) When offshore pipelines are to be backfilled, the backfilling operations shall be inspected for quality of backfill, possible damage to the pipe coating, and depth of cover.

(21) Pipelines shall be inspected for spans.

(22) Pipeline crossings shall be inspected for specified separation.

(23) Where specified, special assemblies and protection measures as described in [para. A402.3.6](#) shall be inspected for protection against damage by outside forces, such as fishing and other marine activities.

## A437 TESTING

### A437.1 General

#### A437.1.4 Testing After New Construction

(a) *Systems or Parts of Systems*

(3) Provisions of [para. 437.1.4\(a\)\(3\)](#) are superseded by the following. All pipe and pressure-containing piping components shall be tested in accordance with the provisions of [para. 437.1.4\(a\)\(2\)](#).

(b) *Testing Tie-Ins.* Nonwelded tie-in connections shall be observed for leaks at operating pressure. Tie-in welds and girth welds joining lengths of pretested pipe shall be inspected by radiographic or other accepted nondestructive methods in accordance with [para. A434.8.3](#), if the system is not pressure-tested after tie-in.

(d) *Hydrostatic Test Medium.* The hydrostatic test medium for all offshore pipeline systems shall be water, except in arctic areas. Additives to mitigate the effects of corrosion, biofouling, and freezing should be considered. Such additives should be suitable for the methods of disposal of the test medium.

In arctic areas where freezing of water is a restraint, the use of air, inert gas, or glycol is allowable, provided appropriate detail considerations are addressed.

Disposal of all materials shall be done in an environmentally safe manner.

(e) *Diameter Restrictions.* Testing for buckles, dents, and other diameter restrictions shall be performed after installation. Testing shall be accomplished by passing a deformation detection device through the pipeline section, or by other methods capable of detecting a change in pipe cross section. Pipe having deformation that affects the serviceability of the pipeline facilities shall be repaired or replaced. Consideration should also be given to repairing ovality that may interfere with pigging operations or internal inspections.

#### A437.4 Test Pressure

**A437.4.3 Leak Testing.** Provisions of [para. 437.4.3](#) are not applicable for offshore pipeline systems.

#### A437.6 Qualification Tests

Pipe of unknown specification and ASTM A120 specification pipe are not allowed in offshore pipeline systems. See [para. A423.1](#).

## A437.7 Records

“As-built” records shall also include the location of anodes and buckle arrestors (if used) by pipe joint installation sequence. Subsea valve, tie-in, and other special assembly locations shall be recorded by coordinates.

## A450 OPERATION AND MAINTENANCE PROCEDURES AFFECTING THE SAFETY OF LIQUID AND SLURRY TRANSPORTATION PIPING SYSTEMS

### A450.2 Operation and Maintenance Plans and Procedures

The provisions of [paras. 450.2\(d\)](#), [450.2\(e\)](#), and [450.2\(i\)](#) are superseded by the following:

(d) Have a plan for reviewing conditions affecting the integrity and safety of the pipeline system, including provisions for periodic patrolling and reporting of construction activity and changes in conditions.

(e) Establish and maintain liaisons with local offshore authorities who issue permits in order to prevent accidents caused by new construction. Establish and maintain liaisons with available offshore firefighting and pollution control entities.

(i) In establishing plans and procedures, give particular attention to those portions of the system presenting the greatest hazard to the public and to the environment in the event of emergencies or because of construction or extraordinary maintenance requirements.

## A451 PIPELINE OPERATION AND MAINTENANCE

### A451.1 Operating Pressure

(a) If a component is installed during a repair that has a maximum pressure rating less than the allowable operating pressure of the pipeline, the pipeline shall be derated to the pressure rating of the component, analyzed in accordance with [para. 451.1\(a\)](#).

### A451.3 Line Markers and Signs

(19)

The provisions of [para. 451.3](#) do not apply to offshore pipeline systems.

### A451.4 Right-of-Way Maintenance

The provisions of [para. 451.4](#) do not apply to offshore pipeline systems.

### A451.5 Patrolling

(19)

(a) The provisions of [paras. 451.5\(a\)](#) and [451.5\(b\)](#) are superseded by the following. Each offshore pipeline system operator shall maintain a periodic pipeline patrol program to observe surface conditions on, and adjacent to, the pipeline right-of-way, indication of leaks,

construction activity other than that performed by the operator, and any other factors affecting the safety and operation of the pipeline. Consideration should be given to increased patrols in areas more susceptible to damage by outside forces.

(19) **A451.6 Pipeline Integrity Assessment and Repairs**

As a means of maintaining the integrity of its pipeline system, each operating company shall establish and implement procedures for continuing surveillance of its facilities. Studies shall be initiated and appropriate action taken when unusual operating and maintenance conditions occur, such as failures, leakage history, unexplained changes in flow or pressure, or substantial changes in cathodic protection requirements.

Consideration should be given to inspection of pipelines and pipeline protection measures in areas most susceptible to damage by outside forces. Such areas may include shore crossings, areas near platforms, shipping fairways, pipeline crossings, span rectifications, subsea assemblies, and shallow water areas. If the operating company discovers that the cover or other conditions do not meet the original design, it shall determine whether the existing conditions are unacceptable. If the conditions are unacceptable, the operating company shall provide additional protection by replacing cover, lowering the line, installing temporary or permanent warning markers or buoys, or using other suitable means.

When such studies indicate the facility is in an unsatisfactory condition, a planned program shall be initiated to abandon, replace, or repair. If such a facility cannot be repaired or abandoned, the maximum allowable pressure shall be reduced commensurate with the requirements described in [paras. 451.1\(a\)](#) and [A451.1\(a\)](#).

Offshore pipeline risers shall be visually inspected annually for physical damage and corrosion in the splash zone and above. Consideration should also be given to periodic visual inspection of the submerged zone of the riser. The extent of any observed damage shall be determined, and if the serviceability of the riser is affected, the riser shall be repaired or replaced.

Consideration should be given to the periodic use of internal or external inspection tools to monitor external and internal pipeline corrosion and to detect other unsafe conditions.

Fitness-for-service methodologies as outlined in API RP 579-1/ASME FFS-1 may be used for offshore pipeline systems.

**A451.6.1 General.** Additional requirements for repairs to offshore pipeline systems are as follows:

(a) Repair operations shall not result in imposed deformations that would impair the integrity of the pipe materials, and weight or protective coating.

(b) Subsea equipment used in the repair of offshore pipeline systems shall be carefully controlled and monitored to avoid damaging the pipeline, external coating, or cathodic protection system.

(c) When lifting or supporting pipe during repairs, the curvature of a pipe sag bend and overbend shall be controlled to prevent overstressing, denting, or buckling the pipe or damaging the coating. Lifting equipment shall be selected to comply with this requirement.

(d) Wave and current loads shall be considered in determining total imposed stresses and cyclical loadings in both surface and subsurface repairs.

(e) When pipe is repaired, damaged coating shall be repaired.

(f) Replacement pipe and components shall be protected from corrosion.

Consideration should be given to obtaining pipe-to-water potentials during the repair operations to verify conformance to cathodic protection requirements.

**A451.6.2 Limits and Disposition of Imperfections and Anomalies** (19)

**A451.6.2.9 Permanent Repairs**

(h) Welded fittings allowed by [para. 451.6.2.9\(h\)](#) to cover defects shall not be used in offshore pipeline systems.

**A451.6.4 Repair of Flexible Pipe**

(a) *Major Structural Damage.* If the serviceability of the flexible pipe is impaired, the damaged pipe section shall be replaced.

(b) *Surface Cuts.* In the event of surface cuts and abrasions that do not expose the load-carrying members to potential corrosion, the repair shall be performed in a manner recommended by the manufacturer.

**A451.8 Valve Maintenance**

Provisions of [para. 451.8](#) do not apply to offshore pipeline systems. Pipeline block valves that would be required by the emergency plan (see [sections 454](#) and [A454](#)) to be operated during an emergency shall be inspected periodically, and fully or partially operated at least once a year.

**A451.9 Railroads and Highways Crossing Existing Pipelines**

The provisions of [para. 451.9](#) do not apply to offshore pipeline systems.

**A451.10 Inland Waters Platform Risers** (19)

The provisions of [para. 451.10](#) do not apply to offshore pipeline systems.

## **A452 PUMP STATION, TERMINAL, AND STORAGE FACILITIES OPERATION AND MAINTENANCE**

### **A452.5 Fencing**

Fencing is not applicable for offshore facilities.

### **A452.7 Prevention of Accidental Ignition**

Smoking shall be prohibited in all areas of offshore facilities in which the possible leakage or presence of vapor constitutes a fire or explosion hazard.

## **A454 EMERGENCY PLAN**

(d) The provisions of [para. 454\(d\)](#) do not apply to offshore pipeline systems.

(e)(5) The provisions of [para. 454\(e\)\(5\)](#) do not apply to offshore pipeline systems. To minimize public exposure to injury and to prevent accidental ignition, provisions for halting or diverting marine vessel traffic shall be included in the emergency plan.

## **(19) A460 GENERAL**

(a) In addition to the provisions of [para. 460\(a\)](#), special considerations shall be given to corrosion control of offshore pipeline systems because they cannot easily be inspected after installation and there is the possibility of damage to the coating system. Special attention shall be given to the selection, design, and application of corrosion control coatings, the cathodic protection system, and other corrosion design elements.

(c) NACE SP 0115/ISO 15589-2 provides a guide for procedures to implement requirements herein and to monitor and maintain cathodic protection systems for offshore pipeline systems.

## **(19) A461 EXTERNAL CORROSION CONTROL FOR BURIED OR SUBMERGED PIPELINES**

### **A461.1 New Installations**

#### **A461.1.1 General**

(a) In addition to the provisions of [para. 461.1](#), a minimum clearance of 12 in. (300 mm) shall be maintained between the outside of any offshore pipeline and any other structure that may affect the cathodic protection of the offshore pipeline, except where impractical (e.g., bundled pipelines) and where adequate provisions for corrosion control have been made.

#### **A461.1.2 Coating Requirements**

(f) In addition to the provisions of [paras. 461.1.2](#) and [461.2.8](#), consideration should be given to insulating the carrier pipe from the casing pipe when the carrier pipe is pulled into pull-tube risers. Consideration

should also be given to preventing oxygen replenishment in the water in the annulus between carrier pipe and casing by sealing at least one end of pull-tube risers or other measures to prevent corrosion.

### **A461.1.3 Cathodic Protection Requirements**

(a) In addition to the provisions of [para. 461.1.3](#), where impressed current systems are used, the system shall be designed to minimize outages. The design formula for galvanic anode systems shall include the percentage of exposed pipe, current output of the anodes, design life of the system, anode material, and utilization efficiency. Anodes should be compatible with the operating temperature of the pipeline and the marine environment. Consideration should be given to the effects on cathodic protection of variations in oxygen content, temperature, and water-soil resistivity of the particular offshore environment in which the pipeline is installed.

For installations containing flexible pipe, consideration shall be given to the need for galvanic anodes or impressed current at the end connections. A cathodic protection system shall be installed at the time of pipeline installation or as soon as practical after pipeline installation. Owners of other offshore pipelines or facilities that may be affected by installation of a cathodic protection system shall be notified of said installation.

### **A461.1.4 Electrical Isolation**

(a) In addition to the provisions of [para. 461.1.4](#), consideration shall be given to electrically isolating supporting devices, such as clamps and pipe supports, from the riser on platforms. Wiring and piping connections to an electrically isolated pipeline shall also be insulated from devices grounded to the platform.

### **A461.1.5 Electrical Connections and Monitoring Points**

(a) It is considered impractical to locate test leads on submerged portions of offshore pipeline systems. Consideration should be given to installing test leads on platform risers, platform piping, and pipeline shore crossings.

### **A461.1.6 Electrical Interference**

(c) When new pipeline is laid in the vicinity of existing lines, measures shall be taken to minimize electrical interference.

## **A461.3 Monitoring**

(a) Evidence of adequate level of cathodic protection shall be by one or more of the criteria listed in NACE SP 0115/ISO 15589-2.

(b) If repairs are made to offshore pipelines below water, inspection for evidence of external corrosion or coating deterioration shall be made, and necessary

corrective action shall be taken to maintain the corrosion protection of the pipeline.

When an offshore pipeline is lifted above water for maintenance or repair purpose, the operating company shall visually inspect for evidence of coating deterioration, external corrosion, and, where possible, the condition of any exposed anode. If excessive corrosion is present, remedial action shall be taken as necessary.

(c) Consideration should be given to the periodic use of internal inspection tools to monitor external pipeline corrosion.

**A463 EXTERNAL CORROSION CONTROL FOR PIPELINES EXPOSED TO ATMOSPHERE**

(19) **A463.2 New Offshore Installations**

(a) The option of demonstrating “by test, investigation, or experience in area of application that a corrosive atmosphere does not exist” does not apply to offshore pipeline systems. The type of protective coating selected shall be

resistant to the environment existing in offshore locations. The surface preparation and coating application shall be performed in accordance with established specifications and the manufacturer’s recommendations. The selected coating should have the following characteristics:

- (1) low water absorption
- (2) resistance to water action
- (3) compatibility with system operating temperature
- (4) resistance to atmospheric deterioration
- (5) resistance to mechanical damage
- (6) ease of repair

(b) The splash zone area of the offshore pipeline system shall be designed with additional protection against corrosion. This shall be accomplished by one or more of the following:

- (1) special coating
- (2) special protective systems and techniques
- (3) other suitable measures, including selection of pipe material



# Chapter X

## Carbon Dioxide Pipeline Systems

### B400 GENERAL STATEMENTS

(a) Chapter X pertains only to carbon dioxide systems as defined in para. B400.1.

(b) This Chapter is organized to parallel the numbering and content of the first eight chapters of the Code. Paragraph designations are the same as those in the first eight chapters, with the prefix “B.”

(c) All provisions of the first nine chapters of the Code are also requirements of this Chapter unless specifically modified herein. If the text in this Chapter adds requirements, the requirements in the original Chapter with the same title and number also apply. If a provision in this Chapter is in conflict with one or more provisions in other chapters, the provision in this Chapter shall apply.

(d) It is the intent of this Chapter to provide requirements for the design, materials, construction, assembly, inspection, testing, operation, and maintenance of carbon dioxide pipeline systems. It is not the intent of this Chapter to be all inclusive. Engineering judgment must be used to identify special considerations that are not specifically addressed.

It is not the intent of this Chapter to prevent the development and application of new equipment and technology. Such activity is encouraged as long as the safety and reliability requirements of the Code are satisfied.

#### B400.1 Scope

This Chapter covers the design, material requirements, fabrication, installation, inspection, testing, and safety aspects of the operation and maintenance of carbon dioxide pipeline systems. For purposes of this Chapter, carbon dioxide pipeline systems consist of pipe, flanges, bolting, gaskets, valves, relief devices, fittings, and the pressure-containing parts of other piping components.

#### B400.2 Definitions (Applicable to This Chapter Only)

Some of the more common terms relating to carbon dioxide pipelines are defined below.

*carbon dioxide*: a fluid consisting predominantly of carbon dioxide compressed above its critical pressure and, for the purpose of this Code, shall be considered to be a liquid.

### B423 MATERIALS — GENERAL REQUIREMENTS

#### B423.2 Limitations on Materials

**B423.2.6 Materials for Carbon Dioxide Piping Systems.** Blow down and bypass piping in carbon dioxide pipelines shall be of a material suitable for the low temperatures expected. See ASME B31T for more information about evaluating the suitability of piping materials that may be subject to brittle failure due to low-temperature service conditions.

### B434 CONSTRUCTION

#### B434.15 Block and Isolating Valves

**B434.15.2 Mainline Valves.** Paragraph 434.15.2(a) does not apply.

#### B434.18 Line Markers

(b) The marker shall state at least the following on a background of sharply contrasting colors:

(1) The word “Warning,” “Caution,” or “Danger” followed by the words “Carbon Dioxide Pipeline,” all of which, except for markers in heavily developed urban areas, must be in letters at least 1 in. (25.4 mm) high with an approximate stroke of  $\frac{1}{4}$  in. (6.4 mm).

### B437 TESTING

#### B437.4 Test Pressure

##### B437.4.1 Hydrostatic Testing of Internal Pressure Piping

(f) Carbon dioxide pipelines, valves, and fittings shall be dewatered and dried prior to placing in service to prevent the possibility of forming a corrosive compound from carbon dioxide and water.

#### B437.7 Records

For carbon dioxide pipelines, these records shall also include toughness requirements.



## **B451 PIPELINE OPERATION AND MAINTENANCE**

### **B451.6 Pipeline Integrity Assessments and Repairs**

#### **B451.6.1 General**

(c) Repairs shall be covered by a maintenance plan [see para. 450.2(a)] and shall be performed under qualified supervision by trained personnel familiar with the hazards to public safety. The maintenance plan shall consider the appropriate information contained in API RP 2200, API 2201, API 1104, and API RP 1111. It is essential that all personnel working on pipeline repairs understand the need for careful planning of the job, be briefed as to the procedures to be followed in accomplishing the repairs, and follow precautionary measures and procedures outlined in API RP 2200. Personnel working on repairs to pipelines handling carbon dioxide shall also be informed on the specific properties, characteristics, and potential hazards associated with carbon dioxide, as well as precautions to be taken following detection of a leak. Piping in the vicinity of any repair shall be adequately supported during and after the repair.

#### **B454 EMERGENCY PLAN**

(b) The plan shall provide for training of personnel responsible for the prompt execution of emergency action. Personnel shall be informed concerning the char-

acteristics of carbon dioxide in the piping systems and the safe practices in the handling of accidental discharge and repair of the facilities, with emphasis on the special problems and additional precautions in the handling of leaks and repair of systems transporting carbon dioxide. The operating company shall establish scheduled reviews with personnel of procedures to be followed in emergencies at intervals not exceeding 6 months, and reviews shall be conducted such that they establish the competence of the emergency plan.

(c) Procedures shall cover liaison with state and local civil agencies such as fire departments, police departments, sheriff's offices, highway patrols, and other entities in or near the pipeline right-of-way (e.g., electrical and other utilities, highway authorities, and railroads) to provide prompt intercommunications for coordinated remedial action; dissemination of information on location of system facilities; characteristics of the transported carbon dioxide, including additional precautions necessary with leaks from piping systems transporting carbon dioxide; and joint preparation of cooperative action as necessary to ensure the safety of the public in the event of emergencies.

(e)(8) in the case of systems transporting carbon dioxide, assessment of the carbon dioxide released, its effects, and the use of existing means to blow down and control its dispersion at the leak site

# Chapter XI

## Slurry Pipeline Systems

### C400 GENERAL STATEMENTS

(a) Chapter XI pertains only to slurry systems as defined in para. C400.1.

(b) This Chapter is organized to parallel the numbering and content of the first eight chapters of the Code. Paragraph designations are the same as those in the first eight chapters, with the prefix "C."

(c) All provisions of the first nine chapters of the Code are also requirements of this Chapter unless specifically modified herein. If the text in this Chapter adds requirements, the requirements in the original Chapter with the same title and number also apply. If a provision in this Chapter is in conflict with one or more provisions in other chapters, the provision in this Chapter shall apply.

(d) It is the intent of this Chapter to provide requirements for the design, materials, construction, assembly, inspection, testing, operation, and maintenance of slurry pipeline systems. It is not the intent of this Chapter to be all inclusive. Engineering judgment must be used to identify special considerations that are not specifically addressed. It is not the intent of this Chapter to prevent the development and application of new equipment and technology. Such activity is encouraged as long as the safety and reliability requirements of the Code are satisfied.

#### C400.1 Scope

This Chapter covers the design, material requirements, fabrication, installation, inspection, testing, and safety aspects of the operation and maintenance of slurry pipeline systems. For purposes of this Chapter, slurry pipeline systems consist of pipe, flanges, bolting, gaskets, valves, relief devices, fittings, and the pressure-containing parts of other piping components.

#### (19) C400.2 Definitions (Applicable to This Chapter Only)

Some of the more common terms relating to slurry pipelines are defined below.

*cast iron*: a generic term for the family of high carbon-silicon-iron casting alloys including gray iron, white iron, malleable iron, and ductile iron.

*ductile iron*: a gray iron base metal to which an inoculant is added to the molten state so that upon solidification, the graphite is present in the form of spheres or nodules randomly distributed in a matrix of ferrite. A minimum tensile strength of 60,000 psi (414 MPa) is required.

*erosion*: destruction of materials by the abrasive action of moving fluids, usually accelerated by the presence of solid particles.

*erosion-corrosion*: a corrosion reaction accelerated by the relative movement of the corrosive fluid and the metal surface.

*malleable iron*: a cast iron that, after being cast as white iron, is converted by heat treatment into a matrix of ferrite containing randomly distributed particles of temper carbon and substantially free from all combined carbon. A minimum tensile strength of 50,000 psi (345 MPa) is required.

*slurry*: a two-phase mixture of solid particles in an aqueous phase.

### C401 LOADS

#### C401.2 Application of Loads

##### C401.2.3 Occasional Loads

**C401.2.3.7 Temperature Effects.** Attention should be given to the low-temperature properties of the materials used for facilities to be exposed to unusually low ground temperatures, the potential freezing of aqueous slurry, low atmospheric temperatures, or transient operating conditions.

Consideration in the design shall also be given to the possibility of freezing of fluid in a piping component.

### C403 CRITERIA FOR PIPELINES

#### C403.2 Criteria for Pipe Wall Thickness and Allowances

$F$  = when designing pipelines for slurry service, users of this Code shall elect to use a design factor up to  $F = 0.80$ .

### C403.3 Criteria to Prevent Yield Failure

**C403.3.1 Strength Criteria.** In slurry pipelines, the sum of the longitudinal stresses produced by pressure, live and dead loads, and those produced by occasional loads, such as wind or earthquake, shall not exceed 88% of the specified minimum yield strength of the pipe. It is not necessary to consider wind and earthquake as occurring concurrently.

### C403.15 Other Slurry Design Considerations

The designer should consider that the combination of solids and liquids present in slurry pipelines may require design criteria differing from those applicable to liquid or gas pipelines. These criteria include, but are not limited to, the following: pipeline slope limitations, pressure effects of density differential, equipment malfunction due to solids accumulation, and shutdown/restart effects.

## C404 CRITERIA FOR FITTINGS, ASSEMBLIES, AND OTHER COMPONENTS (ALTERNATIVELY, CRITERIA FOR COMPONENTS)

### C404.2 Directional Changes

**C404.2.4 Mitered Bends.** The designer is cautioned that the abrupt changes in contour inherent in a mitered bend may cause erosion when used in slurry applications.

### C404.3 Branch Connections

**C404.3.1 General.** The possibility of erosion should be considered in slurry service wherever piping discontinuities occur.

### C404.4 Flanges

- (19) **C404.4.1 General.** The design of flanges manufactured in accordance with this paragraph and standards or specifications listed in [para. 404.4.1](#) and [Table C423.1-1](#), subject to exclusions in [Tables C423.1-2](#) and [C426.1-2](#), shall be considered suitable for use at the pressure-temperature ratings as set forth in [para. 404.1.2](#).

### C404.5 Valves

**C404.5.1 General.** Steel valves conforming to standards and specifications listed in [Tables C423.1-1](#) and [426.1-1](#), except for specifications listed in [Table C426.1-2](#), may be used. Cast iron valves conforming to standards and specifications listed in [Tables C423.1-1](#) and [426.1-1](#) may be used for pressures not exceeding 250 psi (17 bar).

**C404.5.2 Special Valves.** Special valves not listed in [Tables C423.1-1](#) and [426.1-1](#) are permitted, provided that they are of at least equal strength and tightness and they are capable of withstanding the same test re-

quirements as covered in the listed standards, and structural features satisfy the material specification and test procedures of valves in similar service set forth in the listed standards.

### C404.6 Reducers

**C404.6.3 Orange Peel Swages.** Orange peel swages shall not be used in slurry applications.

## C423 MATERIALS — GENERAL REQUIREMENTS

### C423.2 Limitations on Materials

#### C423.2.1 General

(a) The materials used shall conform to the specifications listed in [Table C423.1-1](#) or shall meet the requirements of this Code for materials not listed.

(b) The designer of slurry pipeline systems shall give consideration to the effects of corrosion, erosion (see [Chapter VIII](#)), and other deterioration and provide suitable means to mitigate deterioration of the materials in service.

#### C423.2.4 Cast, Ductile, Malleable, and Wrought Iron

(c) Cast irons, including ductile, malleable, and wrought, are acceptable for use, provided the safety of the material selection is demonstrated by

(1) an established history of safe operation for similar parts or items operating under comparable service conditions; or

(2) a satisfactory proof test of prototype production parts or items under simulated service conditions. The designer is cautioned to give attention to the mechanical and impact loadings and low-temperature limitations of cast irons.

## C426 DIMENSIONAL REQUIREMENTS FOR STANDARD AND NONSTANDARD PIPING COMPONENTS

### C426.1 Standard Piping Components

Dimensional standards not applicable for slurry piping components are listed in [Table C426.1-2](#).

## C434 CONSTRUCTION

### C434.21 Storage and Working Tankage

#### C434.21.3 Tanks and Pipe-Type Storage

(e) Tanks for storage or handling slurries may have open tops and shall be constructed in accordance with any of the following standards: API 650, API 12D, API 12F, or AWWA D100.

**Table C423.1-1 Material Standards**

Standard or Specification	Designation
<b>Pipe</b>	
Welded and Seamless Wrought Steel Pipe	ASME B36.10M
Ductile Iron Pressure Pipe	ASTM A377
Electric-Fusion-Welded Steel Pipe for High-Pressure Service at High Temperatures	ASTM A691
<b>Fittings, Valves, and Flanges</b>	
Gray Iron Pipe Flanges and Flanged Fittings (Classes 25, 125, and 250)	ASME B16.1
Gray Iron Threaded Fittings Classes 125 and 250	ASME B16.4
Metallic Gaskets for Pipe Flanges: Ring-Joint, Spiral-Wound, and Jacketed	ASME B16.20
Nonmetallic Flat Gaskets for Pipe Flanges	ASME B16.21
Buttwelding Ends	ASME B16.25
Ductile Iron Castings	ASTM A536
Gray Iron Gate Valves Flanged and Threaded	MSS SP-70
Cast Iron Swing Check Valves, Flanged and Threaded Ends	MSS SP-71
Ball Valves With Flanged or Butt-Welding Ends for General Service	MSS SP-72
Gray Iron Plug Valves Flanged and Threaded Ends	MSS SP-78

GENERAL NOTE: Materials listed within [Table C423.1-1](#) are acceptable material standards for slurry piping systems. In addition, materials listed within [Table 423.1-1](#) are acceptable material standards for slurry piping systems, unless otherwise noted within [Table C423.1-2](#). Specific editions of standards incorporated in this Code by reference, and the names and addresses of the sponsoring organizations, are shown in [Mandatory Appendix I](#), since it is not practical to refer to a specific edition of each standard in [Tables 423.1](#) and [C423.1-1](#) and throughout the Code text.

**Table C423.1-2 Material Standards Not Applicable for Slurry Piping Systems From [Table 423.1-1](#)**

Standard or Specification	Designation
<b>Pipe</b>	
Electric Fusion Welded Austenitic Chromium-Nickel Stainless Steel Pipe for High-Temperature Service and General Application	ASTM A358
Welded Large Diameter Austenitic Steel Pipe for Corrosive or High-Temperature Service	ASTM A409
Ferritic/Austenitic (Duplex) Stainless Steel Pipe Electric Fusion Welded With Addition of Filler Metal	ASTM A928
<b>Fittings, Valves, and Flanges</b>	
Subsea Pipeline Valve	API 6DSS

**Table C426.1-2 Dimensional Standards Not Applicable for Slurry Piping Systems From [Table 426.1-1](#)**

Standard or Specification	Designation
<b>Fittings, Valves, and Flanges</b>	
Orifice Flanges	ASME B16.36

Alternatively, such tanks shall be designed and constructed in accordance with other accepted good engineering practices. Provisions should be made to contain possible slurry spills.

**C434.21.6 Slurry Holding Ponds**

(a) When required, slurry holding ponds shall be constructed to plans and specifications and shall be of sufficient size to contain slurry discharged during normal and emergency operating conditions.

(b) Slurry holding ponds shall be located so as to ensure that process water is retained for reuse or meets the water quality standards of the area prior to disposal.

**C434.23 Slurry Metering**

**C434.23.1** Slurry metering should be accomplished by use of measurement equipment that is compatible with the slurry being measured.

**C437 TESTING**

**C437.4 Test Pressure**

**C437.4.1 Hydrostatic Testing of Internal Pressure Piping**

(a) Portions of piping systems to be operated at a hoop stress of more than 20% of the specified minimum yield strength of the pipe shall be subjected at any point to a hydrostatic proof test equivalent to not less than 1.1 times the internal design pressure at that point (see

para. 401.2.2.2) for not less than 4 hr. When lines are tested at pressures that develop a hoop stress, based on nominal wall thickness, in excess of 90% of the specified minimum yield strength of the pipe, special care shall be used to prevent overstrain of the pipe.

(c) The test liquid shall be water or another nonhazardous liquid.

## **C451 PIPELINE OPERATION AND MAINTENANCE**

### **C451.5 Patrolling**

(a) Patrols for piping systems transporting slurry shall be conducted at intervals not exceeding 1 month.

### **C454 EMERGENCY PLAN**

(b) The operating company shall establish scheduled reviews with personnel of procedures to be followed in emergencies at intervals not exceeding 12 months, and reviews shall be conducted such that they establish the competence of the emergency plan.

### **C457 ABANDONING A PIPING SYSTEM**

In the case of slurry systems where the transported material is inert and nonhazardous, line purging is not required.

### **C460 GENERAL**

(e) Internal corrosion and erosion require special consideration in slurry piping systems. Erosion and corrosion are recognized individually as well as in combination.

Seldom can either one be fully eliminated from consideration. In some cases, the presence of erosion can greatly accelerate the corrosive effects of the slurry medium through removal of protective scales, oxides, or films. The use of inhibitors and/or erosion–corrosion allowance may provide suitable means for dealing with the issue. Other means may be appropriate.

## **C461 EXTERNAL CORROSION CONTROL FOR BURIED OR SUBMERGED PIPELINES**

### **C461.2 Existing Buried Steel Pipelines**

Conversion of existing nonslurry piping systems to slurry service must meet the requirements for new installations as stipulated in [Chapter VIII](#). The conversion date of such piping systems shall be regarded as the installation date for the purposes of this Code.

### **C468 RECORDS**

(b) For slurry pipelines, results of all tests, surveys, and inspections required by this Chapter to indicate the adequacy of corrosion and erosion control measures, as well as records relating to routine or unusual inspections, such as internal or external line conditions when cutting or hot tapping the line, shall be maintained for the service life of the piping system.

# MANDATORY APPENDIX I REFERENCED STANDARDS

Specific editions of standards incorporated in this Code by reference, and the names and addresses of the sponsoring organizations, are shown in this Appendix. It is not practical to refer to a specific edition of each standard throughout the Code text; instead, the specific edition reference dates are shown here. [Mandatory Appendix I](#) will be revised at intervals as needed. An asterisk (\*) is used to indicate those standards that have been accepted as American National Standards by the American National Standards Institute (ANSI). For ASME codes and standards, the latest published edition in effect at the time this Code is specified is the specific edition referenced by this Code unless otherwise specified in the design.

<b>API Standards and Other Publications</b>	<b>API Standards and Other Publications (Cont'd)</b>	<b>ASTM Specifications (Cont'd)</b>
RP 2A-WSD, 21st Ed., 2000 & Err./Supp. 1-2002, Err./Supp. 2-2005, Err./Supp. 3-2007	RP 1111, 3rd Ed., 1999	A105/A105M-05
Std. 2RD	RP 1117, 3rd Ed., 2008 & Err. 1-2008	A106/A106M-08 [Note (3)]
Spec. 5B, 15th Ed., 2008	RP 1130, 1st Ed., 2007	A126-04
*Spec. 5L, 44th Ed., 2007 & Err. 1-2009, Add. 1-2009 [Note (1)]	Std. 2015, 6th Ed., 2001	A134-96 (2005)
*RP 5L1, 6th Ed., 1996	RP 2200, 3rd Ed., 1994	A135/A135M-06 [Note (3)]
*RP 5LT, 1st Ed., 2012	Publ. 2201, 5th Ed., 2003	A139/A139M-04
*RP 5LW, 2nd Ed., 1996 (Incorporates 5L1, 5L5, and 5L6)	API Manual of Petroleum Measurement Standards	A181/A181M-06
Spec. 6A, 19th Ed., 2004 & Err. 1-2004, Err. 2-2005, Err. 3-2006, Err. 4-2007, Err. 5-2009, Add. 1-2008, Add. 2-2008, Add. 3-2008, Add. 4-2008	<b>ASME Codes and Standards</b>	A182/A182M-08a
Spec. 6DSS, 1st Ed., 2007 & Err. 1-2007	*ASME Boiler and Pressure Vessel Code	A193/A193M-08b
Spec. 6H, 2nd Ed., 1998 & Err. 1-2008 (R2006)	*B1.1	A194/A194M-08b
*Spec. 12B, 15th Ed., 2008	*B1.20.1	A216/A216M-07
*Spec. 12D, 11th Ed., 2008	*B1.20.3	A217/A217M-07
Spec. 12F, 12th Ed., 2008	*B16.5 [Note (2)]	A225/A225M-03 (2007)
RP 17B, 4th Ed., 2008	*B16.9	A234/A234M-07
RP 500, 2nd Ed., 1997 (R2002) & Err. 1-1998	*B16.10	A242/A242M-04 <sup>E1</sup>
RP 579-1/ASME FFS-1	*B16.20	A283/A283M-03 (2007)
Std. 600, 12th Ed., 2009	*B16.21	A285/A285M-03 (2007)
Std. 602, 8th Ed., 2005	*B16.25	A307-07b
*Std. 603, 7th Ed., 2007	*B16.49	A320/A320M-08
Std. 620, 11th Ed., 2008 & Add. 1-2009	*B31G	A325-07a
Std. 650, 11th Ed., 2007 & Add. 1-2008	*B31T	A333/A333M-05
RP 1102, 7th Ed., 2007 & Err. 1-2008	*B31.5	A350/A350M-07
*Std. 1104, 20th Ed., 2005 & Err. Add. 1-2007, Err. 2-2008	*B36.10M	A354-07a
RP 1109, 3rd Ed., 2003	*B36.19M	A381-96 (2005)
*RP 1110, 5th Ed., 2007	*PCC-2	A395/A395M-99 (2004)
	<b>ASTM Specifications</b>	A420/A420M-07 [Note (4)]
	A6/A6M-08	A449-07b
	A20/A20M-07	A487/A487M-93 (2007)
	A29/A29M-05	A490-97/A490M-08a
	A36/A36M-08	A505-00 (2005)
	A53/A53M-07	A506-05
		A507-06
		A514/A514M-05
		A515/A515M-03 (2007)
		A516/A516M-06



<b>ASTM Specifications (Cont'd)</b>	<b>MSS Standard Practices (Cont'd)</b>	<b>NACE International Standards and Other Publications (Cont'd)</b>
A517/A517M-06	SP-25-2008	SP 0200-2014
A524-96 (2005) [Note (3)]	SP-44-2006	SP 0204-2015
A530/A530M-04a	SP-55-2006	SP 0274-2011
A572/A572M-07	SP-58-2002	RP 0281-2004
A573/A573M-05	SP-61-2003	SP 0286-2007
A575-96 (2007)	SP-67-2002d	RP 0303-2003
A576-90b <sup>e1</sup> (2006)	*SP-69-2003	SP 0375-2018
A633/A633M-01 (2006)	SP-70-2006	SP 0394-2013
A663/A663M-89 <sup>e1</sup> (2006)	SP-71-2005	RP 0399-2004
A671-06	SP-75-2004	RP 0402-2002
A672-08	SP-78-2005a	SP 0490-2007
A675/A675M-03 <sup>e1</sup>		RP 0602-2002
A694/A694M-03		NACE/SSPC Joint Surface Preparation Standards Package
		Corrosion Data Survey — Metals Section, 6th Ed., 1985
<b>AWS Standards</b>		
*A3.0-2001		
*D3.6M-1999		
<b>DNV GL Standard</b>		
ST-F201		
<b>MSS Standard Practices</b>		
SP-6-2007		
	<b>NACE International Standards and Other Publications</b>	
	*SP 0115-2015/ISO 15589-2-2012	
	SP 0169-2007	
	TM 0172-2015	
	MR 0175/ISO 15156-2015	
	SP 0177-2014	
	SP 0185-2011	
	SP 0188-2006	
	SP 0192-2012	
	SP 0198-2010	
		<b>NFPA Codes</b>
		30-2007
		70-2007

GENERAL NOTE: The issue date shown immediately following the number of the standard (e.g., A53/A53M-07 and SP-6-2017) is the effective date of issue (edition) of the standard.

NOTES:

- (1) Use of bell and spigot line pipe not permitted.
- (2) Limited as set forth in [para. 402.2.1](#).
- (3) Approved only if mill hydrostatic test is performed.
- (4) A420/A420M Grade WPL9 is not suitable for anhydrous ammonia due to copper content.

Titles of standards and specifications listed above that are referenced in the text but do not appear in [Table 423.1-1](#), Material Standards and Specifications, or [Table 426.1-1](#), Dimensional Standards, are as follows:

API	...	Manual of Petroleum Measurement Standards
API	2A-WSD	Recommended Practice for Planning, Designing, and Constructing Fixed Offshore Platforms — Working Stress Design
API	5L1	Recommended Practice for Railroad Transportation of Line Pipe
API	5LT	Recommended Practice for Truck Transportation of Line Pipe
API	5LW	Recommended Practice for Transportation of Line Pipe on Barges and Marine Vessels
API	12B	Specification for Bolted Tanks for Storage of Production Liquids
API	12D	Specification for Field Welded Tanks for Storage of Production Liquids
API	12F	Specification for Shop Welded Tanks for Storage of Production Liquids
API	17B	Recommended Practice for Flexible Pipe
API	500	Recommended Practice for Classification of Locations for Electrical Installations at Petroleum Facilities Classified as Class I, Division 1 and Division 2
API	620	Design and Construction of Large, Welded, Low-Pressure Storage Tanks
API	650	Welded Tanks for Oil Storage
API	1102	Steel Pipelines Crossing Railroads and Highways
API	1104	Welding of Pipelines and Related Facilities
API	1109	Marking Liquid Petroleum Pipeline Facilities
API	1110	Pressure Testing of Steel Pipelines for the Transportation of Gas, Petroleum Gas, Hazardous Liquids, Highly Volatile Liquids, or Carbon Dioxide

ASME B31.4-2019

API	1111	Design, Construction, Operation, and Maintenance of Offshore Hydrocarbon Pipelines (Limit State Design)
API	1130	Computational Pipeline Monitoring for Liquids
API	2015	Requirements for Safe Entry and Cleaning of Petroleum Storage Tanks
API	2200	Repairing Crude Oil, Liquefied Petroleum Gas, and Product Pipelines
API	2201	Safe Hot Tapping Practices in the Petroleum and Petrochemical Industries
ASME	...	Boiler and Pressure Vessel Code, Section VIII, Division 1, Pressure Vessels; Section VIII, Division 2, Alternative Rules for Pressure Vessels; and Section IX, Welding, Brazing, and Fusing Qualifications
ASME	B31G	Manual for Determining the Remaining Strength of Corroded Pipelines: A Supplement to B31, Code for Pressure Piping
ASME	B31T	Standard Toughness Requirements for Piping
ASME	B31.5	Refrigeration Piping
AWS	A3.0	Welding Terms and Definitions
AWS	D3.6M	Specification for Underwater Welding
EPRI	EL-3106	Safety of Pipelines in Close Proximity to Electrical Transmission Lines
NACE	57519	Corrosion Data Survey — Metals Section
ANSI/NACE	SP 0115/ISO 15589-2	Petroleum, petrochemical and natural gas industries — Cathodic protection of pipeline transportation systems — Part 2: Offshore Pipelines
NACE	SP 0169	Standard Practice — Control of External Corrosion on Underground or Submerged Metallic Piping Systems
NACE	TM 0172	Test Method — Determining Corrosive Properties of Cargoes in Petroleum Product Pipelines
ANSI/NACE	MR 0175/ISO 15156	Petroleum and natural gas industries — Materials for use in H <sub>2</sub> S-containing environments in oil and gas production
NACE	SP 0177	Standard Practice — Mitigation of Alternating Current and Lightning Effects on Metallic Structures and Corrosion Control Systems
NACE	SP 0185	Standard Practice — Extruded Polyolefin Resin Coating Systems With Soft Adhesives for Underground or Submerged Pipe
NACE	SP 0188	Standard Practice — Discontinuity (Holiday) Testing of New Protective Coatings on Conductive Substrates
NACE	SP 0192	Standard Practice — Monitoring Corrosion in Oil and Gas Production With Iron Counts
NACE	SP 0198	Standard Practice — Control of Corrosion Under Thermal Insulation and Fireproofing Materials — A Systems Approach
NACE	SP 0200	Standard Practice — Steel-Cased Pipeline Practices
NACE	SP 0204	Standard Practice — Stress Corrosion Cracking (SCC) Direct Assessment Methodology
NACE	SP 0274	Standard Practice — High-Voltage Electrical Inspection of Pipeline Coatings Counts
NACE	RP 0281	Recommended Practice — Method for Conducting Coating (Paint) Panel Evaluation Testing in Atmospheric Exposures
NACE	SP 0286	Standard Practice — Electrical Isolation of Cathodically Protected Pipelines
NACE	RP 0303	Recommended Practice — Field-Applied Heat-Shrinkable Sleeves for Pipelines: Application, Performance, and Quality Control
NACE	SP 0375	Standard Practice — Field-Applied Underground Wax Coating Systems for Underground Pipelines: Application, Performance, and Quality Control
NACE	SP 0394	Standard Practice — Application, Performance, and Quality Control of Plant-Applied Single Layer Fusion-Bonded Epoxy External Pipe Coating
NACE	RP 0399	Recommended Practice — Plant-Applied, External Coal Tar Enamel Pipe Coating Systems: Application, Performance, and Quality Control
NACE	RP 0402	Recommended Practice — Field-Applied Fusion-Bonded Epoxy (FBE) Pipe Coating Systems for Girth Weld Joints: Application, Performance, and Quality Control
NACE	SP 0490	Standard Practice — Holiday Detection of Fusion-Bonded Epoxy External Pipeline Coatings of 250 to 760 $\mu\text{m}$ (10 to 30 mils)
NACE	RP 0602	Recommended Practice — Field-Applied Coal Tar Enamel Pipe Coating Systems: Application, Performance, and Quality Control
NACE/SSPC	...	Joint Surface Preparation Standards Package
NFPA	30	Flammable and Combustible Liquids Code
NFPA	70	National Electrical Code

Specifications and standards of the following organizations appear in [Mandatory Appendix I](#):

ANSI	American National Standards Institute 25 West 43rd Street New York, NY 10036 Phone: (212) 642-4900 <a href="http://www.ansi.org">www.ansi.org</a>	DNV-GL	Veritasveien 1 1363 Hovik Norway <a href="http://www.dnvgl.com">www.dnvgl.com</a>
API	American Petroleum Institute 200 Massachusetts Avenue NW Suite 1100 Washington, DC 20001-5571 Phone: (202) 682-8000 <a href="http://www.api.org">www.api.org</a>	EPRI	Electric Power Research Institute 3420 Hillview Avenue Palo Alto, CA 94304 Phone: (650) 855-2121 or (800) 313-3774 <a href="http://www.epri.org">www.epri.org</a>
ASME	The American Society of Mechanical Engineers Two Park Avenue New York, NY 10016-5990 Phone: (973) 882-1167 or (800) 843-2763 (U.S. & Canada) <a href="http://www.asme.org">www.asme.org</a>	MSS	Manufacturers Standardization Society of the Valve and Fittings Industry, Inc. 127 Park Street, NE Vienna, VA 22180 Phone: (703) 281-6613 <a href="http://www.msshq.org">www.msshq.org</a>
ASTM	American Society for Testing and Materials 100 Barr Harbor Drive P.O. Box C700 West Conshohocken, PA 19428-2959 Phone: (610) 832-9585 <a href="http://www.astm.org">www.astm.org</a>	NACE	National Association of Corrosion Engineers 15835 Park Ten Place Houston, TX 77084-4906 Phone: (281) 228-6200 or (800) 797-6223 <a href="http://www.nace.org">www.nace.org</a>
AWS	American Welding Society 8669 NW 36 Street, No. 130 Miami, FL 33166 Phone: (305) 443-9353 or (800) 443-9353 <a href="http://www.aws.org">www.aws.org</a>	NFPA	National Fire Protection Association 1 Batterymarch Park Quincy, MA 02169-7471 Phone: (617) 770-3000 or (800) 344-3555 <a href="http://www.nfpa.org">www.nfpa.org</a>

**NONMANDATORY APPENDIX A  
SUBMITTAL OF TECHNICAL INQUIRIES TO THE B31 PRESSURE  
PIPING COMMITTEE**

(19)

The information formerly in this Appendix has been moved to the [Correspondence With the B31 Committee](#) page in the front matter.

**NONMANDATORY APPENDIX B  
PUBLICATIONS THAT DO NOT APPEAR IN THE CODE OR  
MANDATORY APPENDIX I BUT MAY BE OF INFORMATIONAL  
BENEFIT**

API Bulletin D16, Development of Spill Prevention, Control and Countermeasure Plans

API Publication 1157, Hydrostatic Test Water Treatment and Disposal Option for Liquid Pipeline Systems

API Publication 4602, Minimization, Handling, Treatment, and Disposal of Petroleum Products Terminal Wastewater

API RP 505, Recommended Practice for Classification of Locations for Electrical Installation at Petroleum Facilities Classified as Class 1, Zone 0, Zone 1, and Zone 2

API RP 554, Process Instrumentation and Control

API RP 576, Inspection of Pressure Relieving Devices

API RP 1113, Developing a Pipeline Supervisory Control Center

API RP 1123, Development of Public Awareness Programs by Hazardous Liquid Pipeline Operators

API RP 1160, Managing System Integrity for Hazardous Liquid Pipelines

API RP 2003, Protection Against Ignitions Arising Out of Static, Lightning, and Stray Currents

API RP 2350, Overfill Protection for Storage Tanks in Petroleum Facilities

API Spec. 6H, End Closures, Connectors, and Swivels

API Standard 598, Valve Inspection and Testing

API Standard 653, Tank Inspection, Repair, Alteration and Reconstruction

API Standard 2000, Venting Atmospheric and Low Pressure Storage Tanks

API Standard 2610, Design, Construction, Operation, Maintenance, and Inspection of Terminal and Tank Facilities

Publisher: American Petroleum Institute (API), 200 Massachusetts Avenue NW, Suite 1100, Washington, DC 20001-5571 ([www.api.org](http://www.api.org))

# INDEX

(19)

- Abandoning a piping system, 457
- Acceptable butt welded joint design for equal wall thicknesses, Figure 434.8.6-1
- Acceptable butt welded joint design for unequal wall thicknesses, Figure 434.8.6-2
- Acceptable materials and specifications, 423.1
- Acceptable pipeline repair methods for dents, buckles, ripples, wrinkles, leaking, couplings, and defective prior repairs, Table 451.6.2.9-2
- Acceptable pipeline repair methods, Table 451.6.2.9-1
- Allowable values for pipeline system stresses, Table 403.3.1-1
- Anomalies created by manufacturing processes, 451.6.2.6
- Application of loads, 401.2
- Assembly of piping components, 435
- Attachments to pipe, 404.9.4
- Auxiliary and relief piping, 404.12
- Auxiliary piping, 435.5
- Backfilling, 434.11
- Bending properties, 437.6.2
- Bends made from pipe, 434.7.1
- Bends, miters, and elbows, 434.7
- Blisters (pipe), 451.6.2.7
- Block and isolating valves, 434.15
- Bolted blind closures, 404.7.5
- Bolting for insulating flanges, 404.4.8.2
- Bolting for special flanges, 404.4.8.4
- Bolting procedure, 435.2
- Bolting steel to cast iron flanges, 404.4.8.3
- Bolting (materials), 425.4
- Braces, 404.9.3
- Branch connections, 404.3
- Bridge attachments, 434.13.3
- Brittle fractures, 403.7.3
- Buckles, ripples, wrinkles, 451.6.2.8
- Building installation, 434.20.3
- Butt welds, 404.8.1
- Calculation of stress, 402
- Care and handling of materials, 434.22.2
- Casings, 461.1.7, 461.2.8
- Cast iron flanges within scope of standard sizes, 404.4.3
- Cast, malleable, and wrought iron, 423.2.4
- Cathodic protection, 466.1.4
- Cathodic protection criteria, 461.2.4
- Cathodic protection facilities, 464.3, 465.3
- Cathodic protection monitoring, 464.4
- Cathodic protection requirements, 461.1.3
- Classification of loads, 401.1.1
- Closure fittings, 404.7.2
- Closure heads, 404.7.3
- Closures, 404.7
- Coating requirements, 461.1.2
- Coefficient of thermal expansion, 402.21
- Combining of loads, 401.3
- Combining of stresses, 402.7
- Communications (O&M), 451.2
- Components having specific pressure–temperature ratings, 404.1.2
- Connections to main lines, 434.16
- Construction, 434
- Construction loads, 401.14, 401.2.4
- Construction personnel, 434.2.1
- Construction requirements, 434.3.2
- Controls and protective equipment, 434.20.6, 452.2
- Corrective measures, 461.2.3
- Corrosion (allowances), 403.2.3
- Corrosion (anomalies), 451.6.2.2
- Corrosion control, 434.19, 453
- Cracks, 451.6.2.5
- Criteria, 403, 403.2.1, 464.3.1, 465.3.1
- Criteria for allowable stress due to periodic or cyclic loading, 403.3.2
- Criteria for cold worked pipe, 403.11
- Criteria for crossing, 403.8



- Criteria for expansion and flexibility, 403.9
- Criteria for fittings, assemblies, and other components (alternatively, criteria for components), 404
- Criteria for pipe wall thickness and allowances, 403.2
- Criteria for pipelines, 403
- Criteria for shear and bearing stresses, 403.12
- Criteria for structural supports and restraints, 403.13
- Criteria for transient overpressure, 403.3.4
- Criteria for used pipe, 403.10
- Criteria to prevent buckling and excessive ovality, 403.4
- Criteria to prevent fatigue, 403.5
- Criteria to prevent fracture, 403.7
- Criteria to prevent loss of in-place stability, 403.6
- Criteria to prevent yield failure, 403.3
- Crossing attached to bridges, 403.8.5
- Crossings of pipelines and utilities, 403.8.7
- Damage to fabricated items and pipe, 434.5
- Definitions, 400.2
- Dents, 451.6.2.4
- Design considerations, 403.7.2
- Design criteria for welded branch connections, Table 404.3.4-1
- Design current conditions, 403.6.2.2
- Determination of wall thickness, 437.6.3
- Determination of weld joint factor, 437.6.4
- Determination of yield strength, 437.6.6
- Diagram showing scope of ASME B31.4 excluding carbon dioxide systems, Figure 400.1.1-1
- Dikes or firewalls, 434.21.5
- Dimensional requirements for standard and nonstandard piping components, 426
- Dimensional standards, Table 426.1-1
- Directional changes, 404.2
- Directionally drilled crossings (construction), 434.13.5
- Directionally drilled crossings (design), 403.8.3
- Ditching, 434.6
- Ductile fracture, 403.7.4
- Earthquake-prone areas, 403.6.2.6
- Earthquakes, 401.2.3.1
- Electrical connections and monitoring points, 461.1.5
- Electrical installations, 434.22
- Electrical interference, 461.1.6, 461.2.5
- Electrical isolation, 461.1.4
- Electric transmission lines, 461.1.4.2
- Emergency plan, 454
- Evaluation (corrosion), 461.2.2
- Examination when exposed, 461.2.6
- Existing buried or submerged steel pipelines, 461.2
- Existing installation (internal corrosion), 462.3
- Existing installations (external corrosion), 466.2
- External anodes, 466.1.4.1
- External coating requirements, 464.2, 465.2, 466.1.2
- External corrosion control for buried or submerged pipelines, 461
- External corrosion control for pipelines exposed to atmosphere, 463
- External corrosion control for thermally insulated pipelines, 466
- External hydrostatic pressure, 401.2.2.3
- Fabricated closures, 404.7.4
- Fabricated reducers, 404.6.2
- Factory-made bends and elbows, 404.2.5, 434.7.3
- Fencing, 452.5
- Field bends, 404.2.2
- Fire protection, 434.20.7
- Fittings exceeding scope of standard, 404.1.7
- Flange bolts, 404.4.8
- Flange facings, 404.4.6
- Flange gaskets, 404.4.7
- Flange joints, 404.8.2
- Flanges, 404.4
- Flanges exceeding scope of standard sizes, 404.4.4
- Flanges of rectangular cross section, 404.4.5
- Flexibility factor,  $k$ , and stress intensification factor, Figure 402.1-1
- Foreign structures, 461.1.4.1
- Galvanic anode installations, 464.3.3
- Galvanic anodes, 465.3.2
- Gaskets (materials), 425.3
- General criteria for piping components, 404.1
- General statements, 400
- Gouges, grooves, and arc burns, 451.6.2.3
- Handling, hauling, stringing, and storing, 434.4
- Hydrostatic testing (design), 401.2.4.2
- Hydrostatic testing of internal pressure piping, 437.4.1
- Ice loads, 401.2.3.3
- Impressed current facilities, 464.3.2
- Induction bends, 404.2.3
- Inland coastal water construction, 434.14
- Inland waters platform risers, 451.10
- Inspection and testing, 436
- Inspection (qualifications), 434.2.2

- Installation, 434.22.3
- Installation loads, 401.2.4.1
- Installation of pipe in the ditch, 434.10
- Instrument and other auxiliary piping, 404.12.1
- Integrally reinforced extruded outlet headers, 404.3.3
- Internal anodes, 466.1.4.2
- Internal corrosion control, 462, 464.5, 465.4
- Internal design pressure, 401.2.2.2
- Joints, 404.8
- Leak detection, 451.11
- Leak testing, 437.4.3
- Limitations on materials, 423.2
- Limits and disposition of imperfections and anomalies, 451.6.2
- Line markers, 434.18
- Line markers and signs, 451.3
- Liquid metering, 434.23
- Liquid strainers and filters, 434.24
- Load classifications, 401.1
- Longitudinal stress, 402.6
- Mainline valves, 434.15.2
- Maintenance, right of way, 451.4
- Maintenance, valve, 451.8
- Manifolds, 435.4
- Manufactured reducers, 404.6.1
- Material standards, Table 423.1-1
- Materials applied to miscellaneous parts, 425
- Materials for liquid anhydrous ammonia pipeline systems, 423.2.5
- Materials for use in low-temperature applications, 423.2.6
- Materials — general requirements, 423
- Minimum yield strength value, 437.6.7
- Mitered bends (construction), 434.7.2
- Mitered bends (design), 404.2.4
- Moduli of elasticity, 402.2.2
- Nonstandard piping components, 426.2
- Occasional loads, 401.1.3, 401.2.3
- Operating pressure, 451.1
- Operation and maintenance procedures affecting the safety of liquid and slurry transportation piping systems, 450
- Orange peel swages, 404.6.3
- Other pressure-containing components, 404.10
- Overhead crossings (design), 403.8.4
- Overhead structures, 434.13.2
- Overpressure criteria (design), 404.1.5
- Patrolling, 451.5
- Permanent repairs, 451.6.2.9
- Pipe–soil interaction, 403.6.2.7
- Pipeline operation and maintenance, 451
- Pipelines in arctic environments, 464
- Pipelines in high-temperature service, 465
- Poisson's ratio, 402.2.3
- Preheating and interpass temperature, 434.8.8
- Pressure criteria (design), 404.1.4
- Prevention of accidental ignition (pump station), 452.7
- Pump station, tank farm, and terminal construction, 434.20
- Pump station, tank farm, and terminal piping, 434.20.5
- Pump station, tank farm, slurry holding pond, and terminal valves, 434.15.3
- Pump station, terminal and storage facilities operation and maintenance, 452
- Pumping equipment and prime movers, 434.20.4
- Pumping unit piping, 435.3
- Qualification of inspectors, 436.2
- Qualifications (construction), 434.2
- Qualifying a piping system for a higher operating pressure, 456
- Quick-opening closures, 404.7.1
- Railroad and highway crossings, 434.13.4
- Railroad and highway crossings (design), 403.8.6
- Railroads and highways crossing existing pipelines, 451.9
- Ratings — components not having specific pressure–temperature ratings, 404.1.3
- Ratings — considerations for different pressure conditions, 404.1.6
- Recommended attachment details of flanges, Figure 434.8.6-3
- Records, 437.7, 455, 468
- Reducers, 404.6
- Reinforcement of branch connections, Figure 404.3.5-1
- Reinforcement of multiple openings, 404.3.6
- Reinforcement of single openings, 404.3.5
- Relief piping, 404.12.2
- Removal or repair of defects, 434.8.7
- Repair of defects, 436.6
- Repair, pipeline integrity assessments, 451.6
- Required inspection and acceptance criteria, 434.8.5
- Residual loads (design), 401.2.2.5
- Restoration of right-of-way and cleanup, 434.12

- Restrained aboveground pipelines (design), 403.9.3  
 Restrained buried pipelines, 403.9.2  
 Restrained pipe, 402.5.1, 402.6.1  
 Restrained versus unrestrained (design), 401.2.1  
 Road and rail traffic (design), 401.2.3.4  
 Scope, 400.1  
 Scraper traps, 434.17  
 Shore approaches, 403.6.2.4  
 Signs, 452.6  
 Sleeve, coupled and other patented joints, 404.8.4  
 Slope failure and soil liquefaction, 403.6.2.5  
 Special crossings, 434.13  
 Special fittings and connections, 404.1.8  
 Special gasket, 404.4.7.3  
 Special valves, 404.5.2  
 Stability against currents, 403.6.2.3  
 Standard gaskets, 404.4.7.2  
 Standard piping components, 426.1  
 Steel butt welding fittings, 404.1.1  
 Steel flanges within scope of standard sizes, 404.4.2  
 Steel (materials), 423.2.3  
 Storage and working tankage, 434.21  
 Storage facilities, 452.3  
 Storage of combustible materials, 452.4  
 Strain criteria for existing pipelines, 451.12  
 Strain criteria for pipelines (design), 403.3.3  
 Strength criteria (design), 403.3.1  
 Strength criteria during installation and testing (design), 403.6.1  
 Strength criteria during operations, 403.6.2  
 Stress corrosion and other phenomena, 467  
 Stress from external pressure, 402.4  
 Stress from thermal expansion, 402.5  
 Stress properties, 402.2  
 Stress relieving, 434.8.9  
 Stresses from internal pressure, 402.3  
 Stresses from road and rail traffic loads, 402.8  
 Subsidence, 401.2.2.6  
 Supplementary types of examination, 436.5.2  
 Supports, 404.9.2  
 Supports, braces, anchors, and attachments, 404.9  
 Survey and staking or marking, 434.3.3  
 Sustained loads, 401.1.2, 401.2.2  
 Tank foundations, 434.21.4  
 Tanks and pipe-type storage, 434.21.3  
 Tees and crosses, 404.3.2  
 Temperature effects, 401.2.3.7  
 Temporary repairs, 451.6.2.10  
 Test pressure, 437.4  
 Testing after new construction, 437.1.4  
 Testing of fabricated items, 437.1.3  
 Testing of replacement components, 437.1.5  
 Testing repairs to pipelines operating at a hoop stress of more than 20% of the SMYS of the pipe, 451.6.3  
 Transported products, 461.1.4.3  
 Trenched water crossings, 403.8.2  
 Type and extent of examination required, 436.5  
 Types of welds, joint designs, and transition nipples, 434.8.6  
 Unrestrained pipe, 402.6.2, 402.5.2  
 Unrestrained pipelines, 403.9.1  
 Use of high  $d/t$  ratio, 403.2.5  
 Used piping components, 404.1  
 Valves, 404.5  
 Vibration (design), 401.2.3.5  
 Visual examination, 437.6.1  
 Wall thickness and defect tolerances, 403.2.2  
 Water crossings, 434.13.1  
 Water stops, 466.1.3  
 Waves and currents, 401.2.3.6  
 Weight effects, 401.2.2.4  
 Weld joint factors applicable to common pipe specifications, Table 403.2.1-1  
 Weldability, 437.6.5  
 Welded branch connections, 404.3.4  
 Welder and welding procedure qualifications, 434.8.3  
 Welding details for opening with localized-type reinforcement, Figure 404.3.4-2  
 Welding details for openings with complete encirclement types of reinforcement, Figure 404.3.4-1  
 Welding details for openings without reinforcement other than that in header and branch walls, Figure 404.3.4-3  
 Welding processes and filler metal, 434.8.2  
 Welding qualification tests, 437.6  
 Welding standards, 434.8.4  
 Welding, 434.8  
 Wind loads, 401.2.3.2  
 Wrinkle bends, 404.2.6

**Offshore Liquid Pipeline Systems (Chapter IX)**

- Acceptable materials and specifications, A423.1
- Allowances, A402.4
- Backfilling, A434.11
- Bends made from pipe, A434.7.1
- Bends, miters, and elbows, A434.7
- Block and isolating valves, A434.15
- Bottom soils, A401.10.4, A401.11.4, A401.9.4
- Branch connections, A404.3
- Calculation of stresses, A402
- Closures, A404.7
- Construction, A434
- Criteria for expansion and flexibility, A403.9
- Criteria for fittings, assemblies, and other components (alternatively, criteria for components), A404
- Criteria for pipe wall thickness and allowances, A403.2
- Criteria for pipelines, A403
- Definitions, A400.2
- Design and protection of special assemblies, A402.3.10
- Design conditions, A401
- Design conditions, offshore, A401.1.1
- Design factors for offshore pipeline systems, Table A402.3.5-1
- Design of clamps and supports, A402.3.7
- Design of connectors and flanges, A402.3.8
- Design of flexible pipe, A402.3.11
- Design of pipe-supporting elements, A421
- Design of pipeline crossings, A402.3.12
- Design of structural pipeline riser protectors, A402.3.9
- Directional changes, A404.2
- Ditching, A434.6
- Emergency plan, A454
- Environmental loads during hydrostatic test, A401.11.3
- Environmental loads during installation, A401.9.3
- Environmental loads during operation, A401.10.3
- External corrosion control for offshore submerged pipelines exposed to the atmosphere, A463
- Fabricated closures, A404.7.4
- Fencing, A452.5
- Flange facings, A404.4.6
- Flanges, A404.4
- Flexible pipe, A405.2
- General, A404.4.1, A460
- General statements, A400
- Hydrostatic test design considerations, A401.11
- Hydrostatic test loads, A401.11.2
- Inspection, A434.2, A436
- Installation design considerations, A401.9
- Installation loads, A401.9.2
- Installation procedures and equipment, A434.14.2
- Joints, A404.8.3
- Leak testing, A437.4.3
- Limitations on materials, 423.2
- Line markers, A434.18
- Loads for hydrostatic test design, A401.11.1
- Loads for installation design, A401.9.1
- Loads for operational design, 401.10.1
- Markers, A451.3
- Materials — general requirements, A423
- Mitered bends, A404.2.4
- Movement of existing pipelines, A434.14.3
- New offshore installations, A463.1
- Offshore pipeline construction, A434.14
- Offshore pipeline risers, A451.10
- Operating pressure, A451.1
- Operation and maintenance plans and procedures, A450.2
- Operation and maintenance procedures affecting the safety of liquid and slurry transportation piping systems, A450
- Operational design considerations, A401.10
- Operational loads, 401.10.2
- Orange peel swages, A404.6.3
- Other design considerations, A406
- Patrolling, A451.5
- Pigs and internal inspection tools, A406.1
- Pipe, A405
- Pipe depth and alignment, A434.14.1
- Pipeline integrity assessment and repairs, A451.6
- Pipeline operation and maintenance, A451
- Prevention of accidental ignition, A452.7
- Pump station, terminal, and storage facilities operation and maintenance, A452
- Qualification of inspectors, A436.2
- Qualification tests, A437.6
- Railroads and highways crossing existing pipelines, A451.9
- Records, A437.7
- Reducers, A404.6
- Reinforcement of multiple openings, A404.3.6
- Reinforcement of single openings, A404.3.5
- Right of way, A434.3

Right-of-way maintenance, A451.4  
 Route selection considerations, 401.12  
 Scope, A400.1  
 Special components, A406.2  
 Special crossings, A434.13  
 Steel pipe, A405.1  
 Strength criteria during installation and testing, A402.3.4  
 Strength criteria during operation, A402.3.5  
 Stress relieving, A434.8.9  
 Stresses from internal pressure, A402.3  
 Survey and staking or marking, A434.3.3  
 Test pressure, A437.4  
 Testing, A437  
 Testing after new construction, A437.1.4  
 Threaded joints, A404.8.3  
 Type and extent of examination required, A436.5  
 Valve maintenance, A451.8  
 Valves, A404.5  
 Visual, A436.5.1  
 Water crossings, A434.13.1  
 Weld joint factors, A402.4.3  
 Welding, A434.8  
 Welding qualifications, A434.8.3  
 Welding quality, A434.8.5

### **Carbon Dioxide Pipeline Systems (Chapter X)**

Block and isolating valves, B434.15  
 Construction, B434  
 Definitions, B400.2  
 Diagram showing scope of ASME B31.4 for carbon dioxide systems, Figure 400.1.1-2  
 Disposition of defects, B451.6.2  
 Emergency, B454  
 General statements, B400  
 General, B451.6.1  
 Hydrostatic testing of internal pressure piping, B437.4.1  
 Limitations on materials, B423.2  
 Line markers, B434.18  
 Mainline valves, B434.15.2  
 Materials — general requirements, B423  
 Materials for carbon dioxide piping systems, B423.2.6  
 Pipeline integrity assessments and repairs, B451.6  
 Pipeline operation and maintenance, B451  
 Records, B437.7

Repair of flexible pipe, B451.6.4  
 Scope, B400.1  
 Test pressure, B437.4  
 Testing, B437

### **Slurry Pipeline Systems (Chapter XI)**

Abandoning a piping system, C457  
 Applications of loads, C401.2  
 Branch connections, C404.3  
 Cast, ductile, malleable, and wrought iron, C423.2.4  
 Construction, C434  
 Criteria for fittings, assemblies, and other components (alternatively, criteria for components), C404  
 Criteria for pipe wall thickness and allowances, C403.2  
 Criteria for pipelines, C403  
 Criteria to prevent yield failure, C403.3  
 Definitions, C400.2  
 Diagram showing scope of ASME B31.4 for slurry pipeline systems, Figure 400.1.1-3  
 Dimensional requirements for nonstandard piping components, C426  
 Dimensional standards not applicable for slurry piping systems from Table 426.1-1, Table C426.1-2  
 Directional changes, C404.2  
 Emergency plan, C454  
 Existing buried steel pipelines, C461.2  
 External corrosion control for buried or submerged pipelines, C461  
 Flanges, C404.4  
 General, C404.5.1, C423.2.1, C460  
 General statements, C400  
 Hydrostatic testing of internal pressure piping, C437.4.1  
 Limitations on materials, C423.2  
 Loads, C401  
 Material standards, Table C423.1-1  
 Material standards not applicable for slurry piping systems from Table 423.1-1, Table C423.1-2  
 Materials — general requirements, C423  
 Mitered bends, C404.2.4  
 Occasional loads, C401.2.3  
 Other slurry design consideration, C403.15  
 Patrolling, C451.5  
 Pipeline operation and maintenance, C451  
 Records, C468  
 Reducers, C404.6  
 Orange peel swages, C404.6.3

Scope, C400.1  
Slurry holding ponds, C434.21.6  
Slurry metering, C434.23  
Special valves, C404.5.2  
Standard piping components, C426.1  
Storing and working tankage, C434.21

Strength criteria, C403.3.1  
Tanks and pipe-type storage, C434.21.3  
Temperature effects, C401.2.3.7  
Test pressure, C437.4  
Testing, C437  
Valves, C404.5



INTENTIONALLY LEFT BLANK

# ASME CODE FOR PRESSURE PIPING, B31

B31.1-2018	Power Piping
B31.3-2018	Process Piping
B31.3-2010	Tuberías de Proceso
B31.4-2019	Pipeline Transportation Systems for Liquids and Slurries
B31.5-2016	Refrigeration Piping and Heat Transfer Components
B31.8-2018	Gas Transmission and Distribution Piping Systems
B31.8S-2018	Managing System Integrity of Gas Pipelines
B31.8S-2010	Gestión de Integridad de Sistemas de Gasoductos
B31.9-2017	Building Services Piping
B31.12-2014	Hydrogen Piping and Pipelines
B31E-2008	Standard for the Seismic Design and Retrofit of Above-Ground Piping Systems
B31G-2012	Manual for Determining the Remaining Strength of Corroded Pipelines: Supplement to ASME B31 Code for Pressure Piping
B31G-2012	Manual para la determinación de la resistencia remanente de tuberías corroídas
B31J-2017	Stress Intensification Factors ( <i>i</i> -Factors), Flexibility Factors ( <i>k</i> -Factors), and Their Determination for Metallic Piping Components
B31J-2008 (R2013)	Método de prueba estándar para determinar factores de intensificación de esfuerzo (Factores <i>i</i> ) para componentes de tuberías metálicas
B31P-2017	Standard Heat Treatments for Fabrication Processes
B31Q-2018	Pipeline Personnel Qualification
B31Q-2010	Calificación del personal de líneas de tuberías
B31T-2018	Standard Toughness Requirements for Piping

The ASME Publications Catalog shows a complete list of all the Standards published by the Society. For a complimentary catalog, or the latest information about our publications, call 1-800-THE-ASME (1-800-843-2763).

# ASME Services

ASME is committed to developing and delivering technical information. At ASME's Customer Care, we make every effort to answer your questions and expedite your orders. Our representatives are ready to assist you in the following areas:

ASME Press	Member Services & Benefits	Public Information
<i>Codes &amp; Standards</i>	Other ASME Programs	Self-Study Courses
Credit Card Orders	Payment Inquiries	Shipping Information
IMechE Publications	Professional Development	Subscriptions/Journals/Magazines
Meetings & Conferences	Short Courses	Symposia Volumes
Member Dues Status	Publications	Technical Papers

## How can you reach us? It's easier than ever!

There are four options for making inquiries\* or placing orders. Simply mail, phone, fax, or E-mail us and a Customer Care representative will handle your request.

<i>Mail</i>	<i>Call Toll Free</i>	<i>Fax—24 hours</i>	<i>E-Mail—24 hours</i>
<b>ASME</b>	<b>US &amp; Canada:</b> 800-THE-ASME	973-882-1717	customer care@asme.org
150 Clove Road, 6th Floor	(800-843-2763)	973-882-5155	
Little Falls, New Jersey	<b>Mexico:</b> 95-800-THE-ASME		
07424-2139	(95-800-843-2763)		

\*Customer Care staff are not permitted to answer inquiries about the technical content of this code or standard. Information as to whether or not technical inquiries are issued to this code or standard is shown on the copyright page. All technical inquiries must be submitted in writing to the staff secretary. Additional procedures for inquiries may be listed within.

# ASME B31.4-2019

ISBN 978-0-7918-7317-5



9 780791 873175



A 0 3 8 1 9